

Sylvia barstool

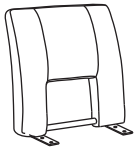

Sylvia barstool



Ax1



Bx1

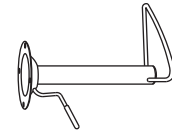

Cx1



Dx1

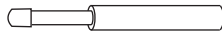

Ex1



Fx1

Gx4



M6*16

Hx4



M6*25

Kx8



Lx1

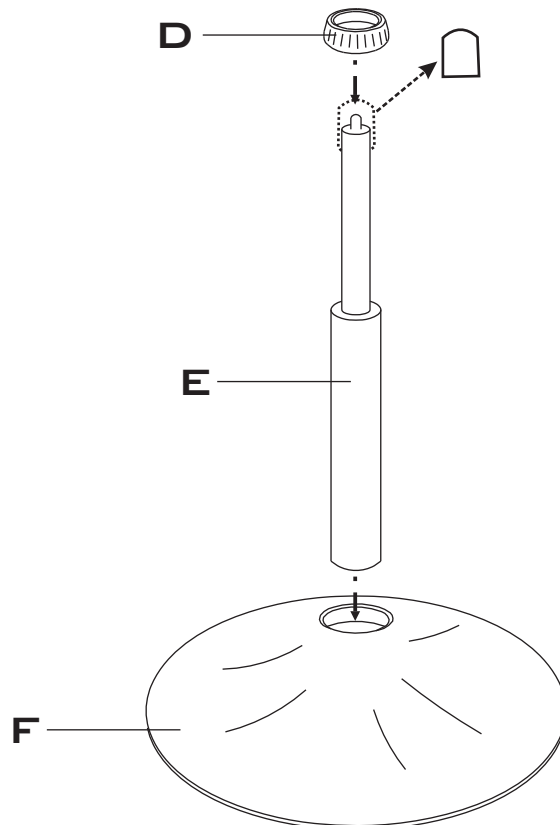

Gx4
M6*16

Hx4
M6*25

Kx8

Lx1

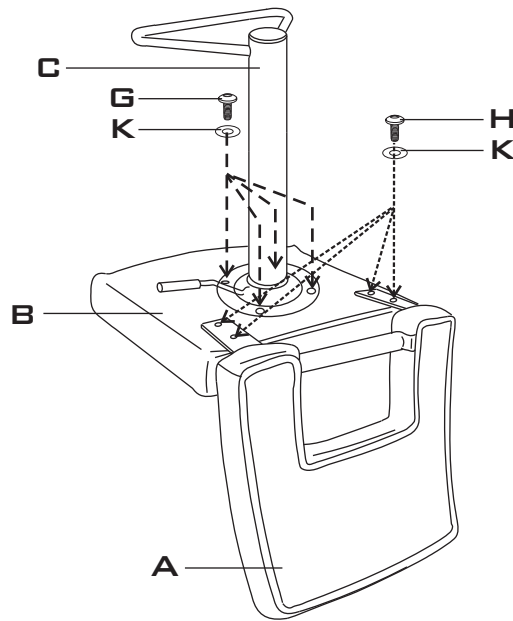

2

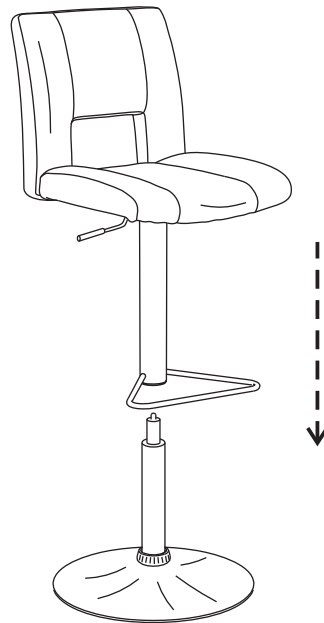

3

