

**Gebrauchsanleitung / Instructions / Mode d'emploi /  
Gebruiksaanwijzing / Instrucciones**

**PAIDI**  
Möbel GmbH  
Hauptstraße 87  
D-97840 Hafeloehr/Main

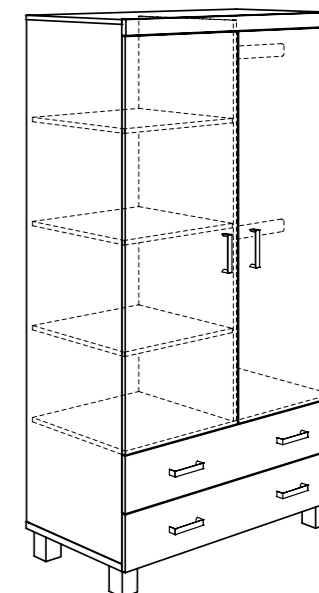

- 124 1000**
- 124 1040**
- 124 1042**
- 124 1043**
- 124 1045**
- 124 1049**
- 124 1140**
- 167 1040**
- 167 1043**
- 167 1045**
- 167 1049**
- 167 1064**



1:1  
DIN A3

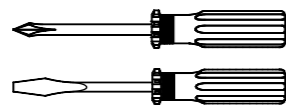
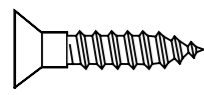
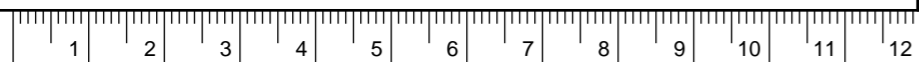

ca. 1,5h



<b>A</b>  16x 681 0759	<b>B</b>  4x 681 1645	<b>C</b>  6x 681 2793	<b>F</b>  4x 681 4887
---------------------------------	--------------------------------	--------------------------------	--------------------------------

<b>G</b>  4x 681 7254	 681 7175 4x	 1x 681 3014	<b>H</b>  6x 681 2497	<b>I</b>  6x 681 5060	<b>L</b>  8x 681 2498
--------------------------------	--------------------	--------------------	--------------------------------	--------------------------------	--------------------------------

<b>J</b>  12x 681 0350	<b>K</b>  2x 681 8126	<b>Z</b>  12x 681 3807	 6x 681 2552
---------------------------------	--------------------------------	---------------------------------	--------------------

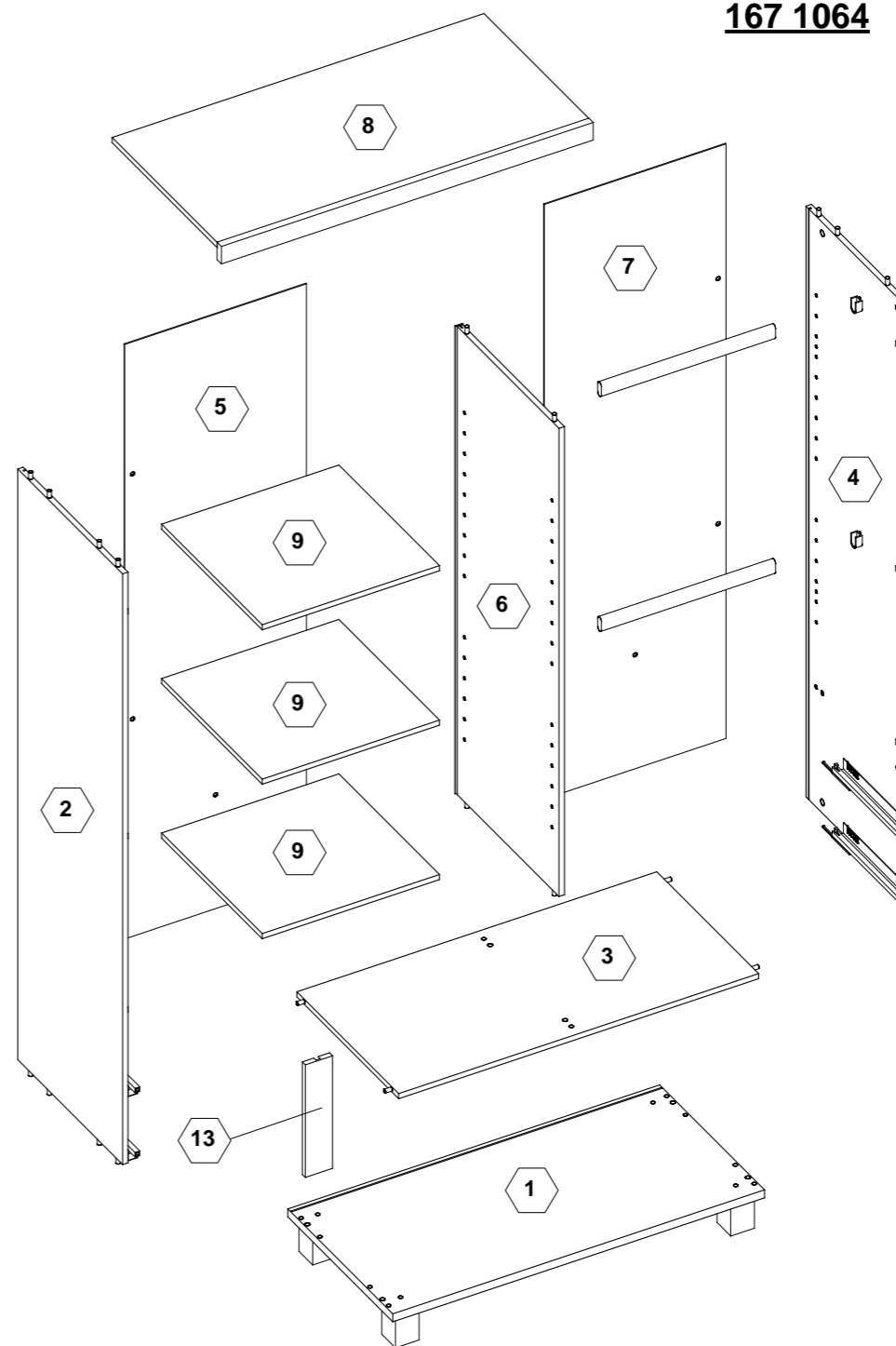
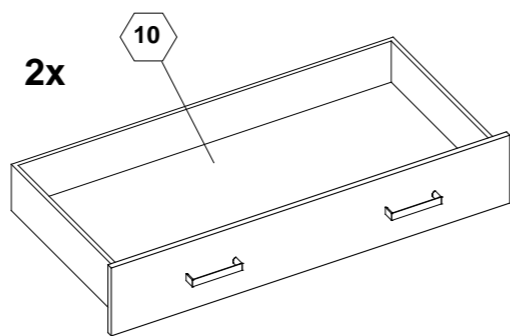
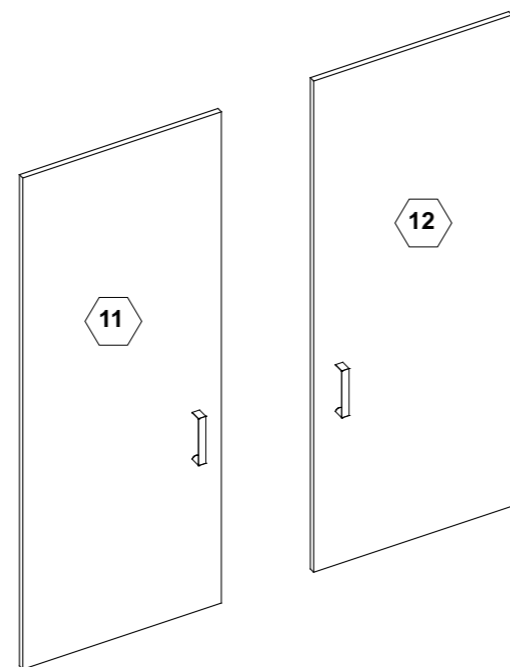

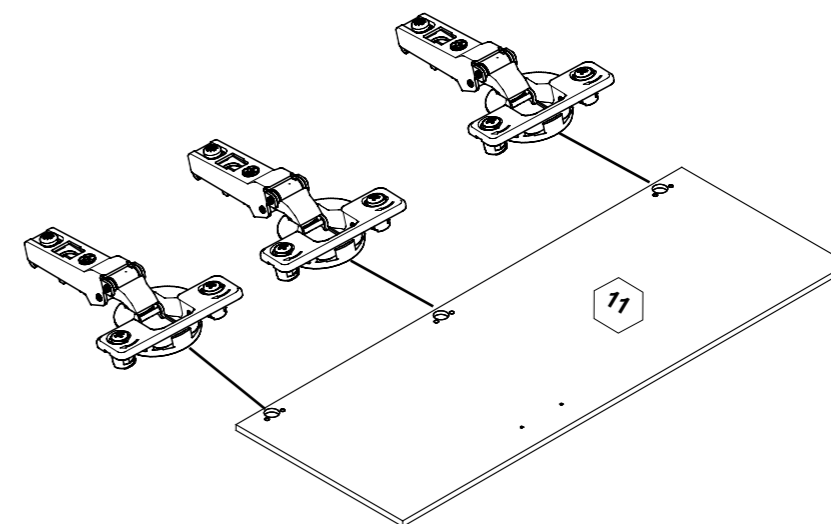
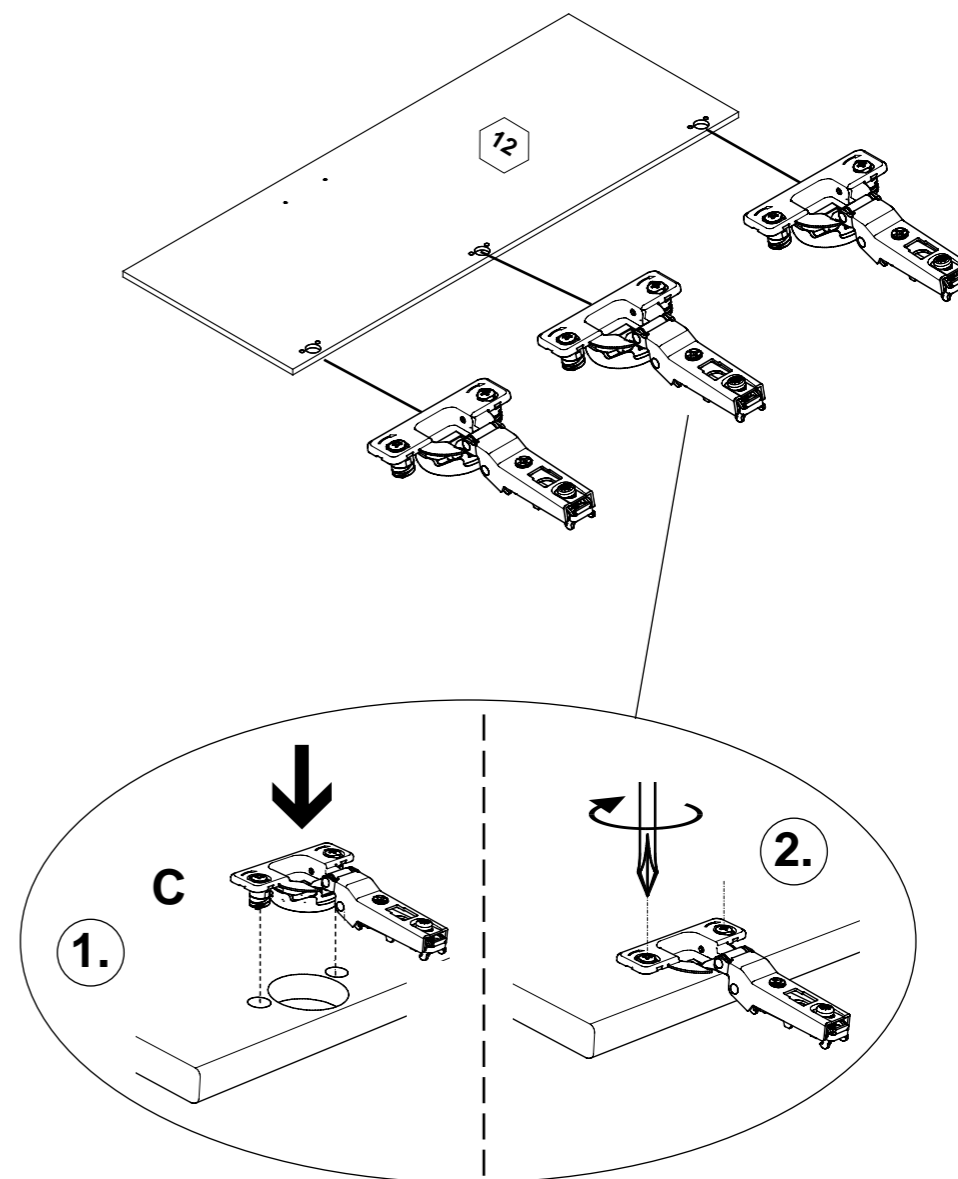
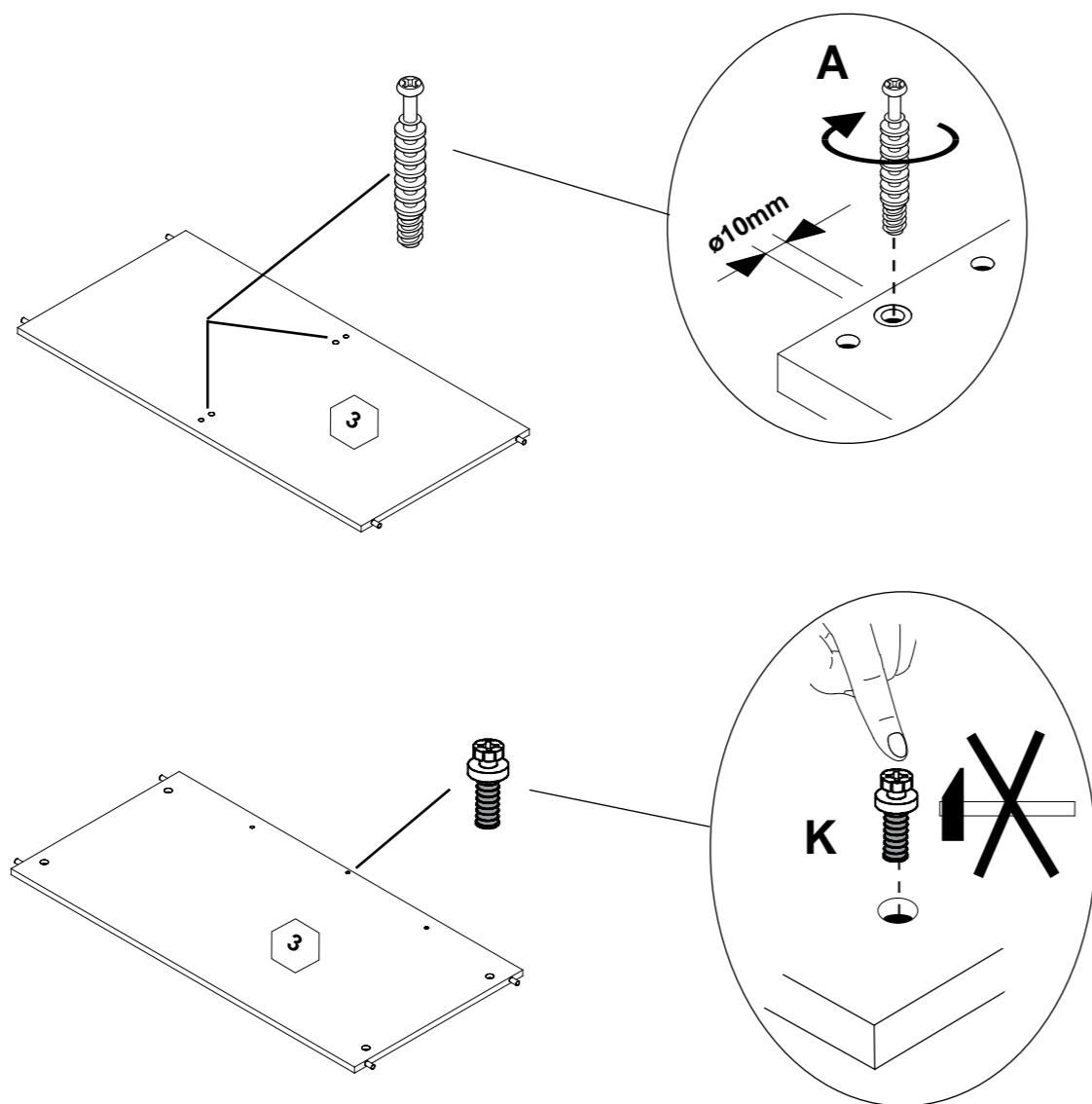

- DE **Pflegehinweis:** Zum Reinigen der Oberflächen ein leicht-feuchtes Tuch oder ein handelsübliches Möbelpflegemittel verwenden.
- FR **Indication sur l'entretien :** pour nettoyer les surfaces, utiliser un chiffon légèrement humide ou un nettoyeur pour meubles en vente dans le commerce
- GB **Caring for the...** : In order to clean the surfaces please use a slightly damp cloth or commercially available furniture care product.
- NL **Verzorgingsanwijzing:** Voor het reinigen van de oppervlakken een licht vochtig doek of een gebruikelijk meubelschoonmaakmiddel gebruiken.
- ES **Recomendaciones de cuidado:** Para limpiar las superficies del mueble debe usar un trapo humedecido o un producto de limpieza de muebles comercial.
- GR **Οδηγίες περιποίησης:** Για το καθαρισμό των επιφανειών να χρησιμοποιείτε ένα ελαφρά νοτισμένο πανάκι ή λούστρο επίπλων.
- IT **Indicazione per pulizia e cura:** Per la pulizia delle superfici utilizzate un panno leggermente umido o un normale prodotto per la cura dei mobili.
- CZ **Pokyny k čištění:** Na čištění povrchu použijte pouze navlhčený kousek látky nebo běžný prostředek na ošetřování nábytku.
- SK **Pokyn k ošetrovaniu:** Na čistenie povrchu používajte mierne navlhčenú handru alebo bežný čistiaci prostriedok na nábytok.
- SI **Navodilo za nego:** Za čiščenje površin uporabljajte malo vlažno sunjo ali trgovsko običajno sredstvo za nego pohištva.
- DK **Pleje:** Rens overflader med en fugtig klud eller et gængs møbelplejemediel.
- SE **Skötselråd:** Rengör ytorna med en fuktig trasa eller med ett vanligt möbелrengöringsmedel som finns i handeln.
- FI **Hoito-ohje:** Käytä pintojen puhdistukseen kosteata pyyhettä tai yleisen kauppalaadun mukaista huonekalujen hoito-ainetta.
- PL **Wskazówka pielęgnacyjna:** do czyszczenia powierzchni stosować lekko wilgotną ściereczkę lub zwykły środek do pielęgnacji mebli.
- HU **Ápolási útmutatás:** A felületek tisztításához egy enyhén nedves kendőt, vagy kereskedelemben kapható, szokványos bútorpóroló szert használjon.
- RO **Indicații de întreținere:** pentru curățirea suprafețelor folosiți o cârpă umezită ușor sau un produs comercial obișnuit pentru îngrijirea mobilei.
- BG **Указание за поддържане:** Използвайте леко навлажнена кърпа или обикновен препарат за поддържане на мебели, за да почистите повърхностите.
- HR **Upute za njegu:** Za čišćenje površina upotrijebiti jednu lako navlaženu krpu i trgovačko uobičajeno sredstvo za njegu namještaja.
- LT **Rekomendacija priežiūrai:** Paviršius valykite drėgna pašluoste arba parduotuvėse įsigyтомis baldų priežiūros priemonėmis.

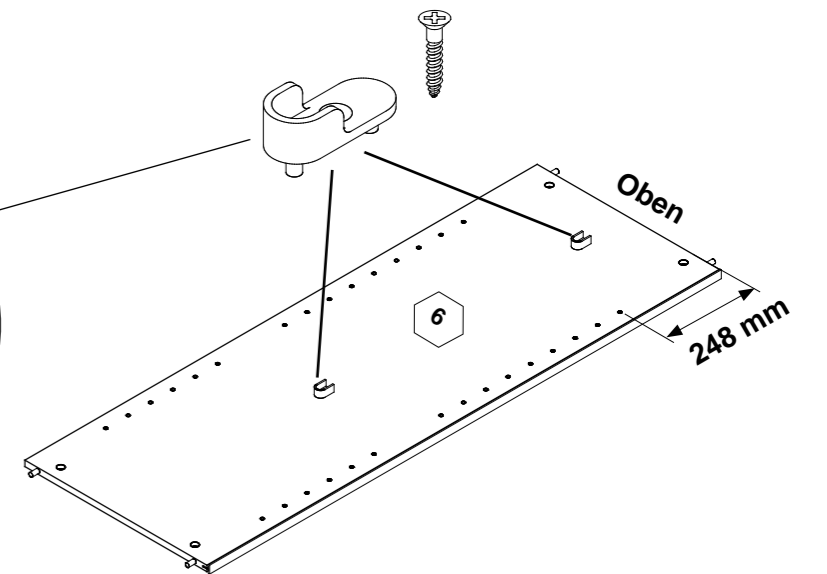
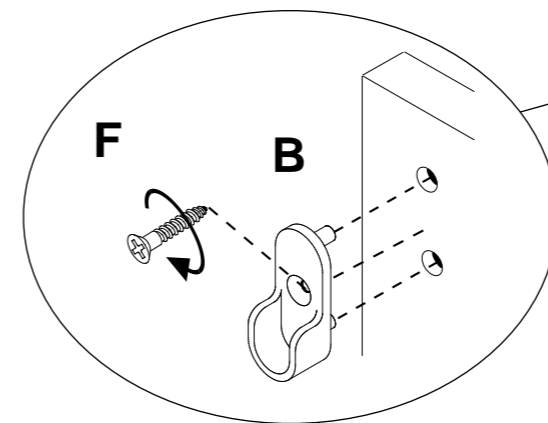
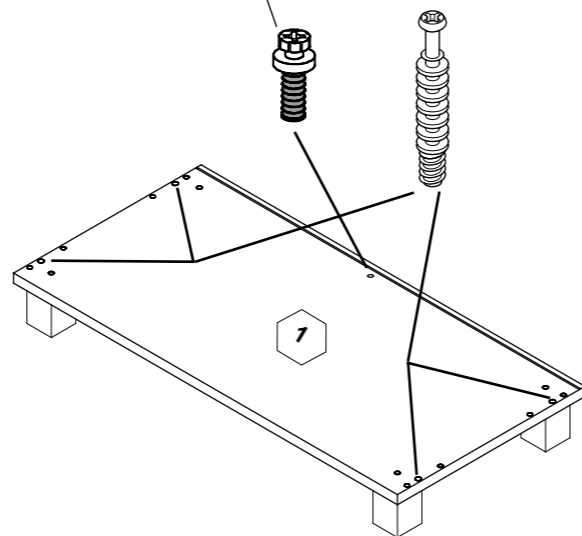
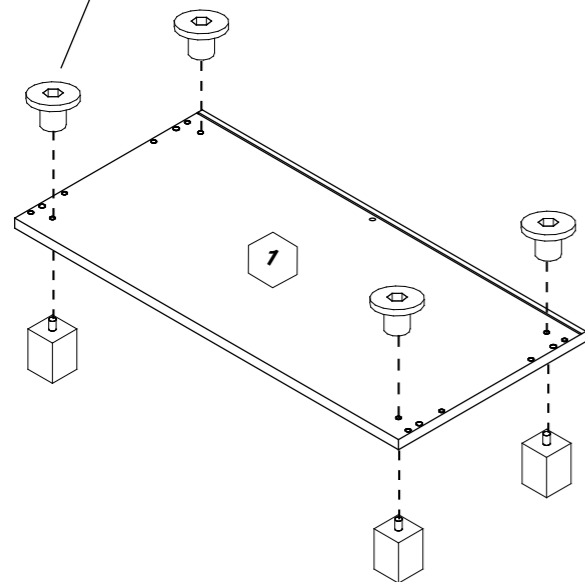
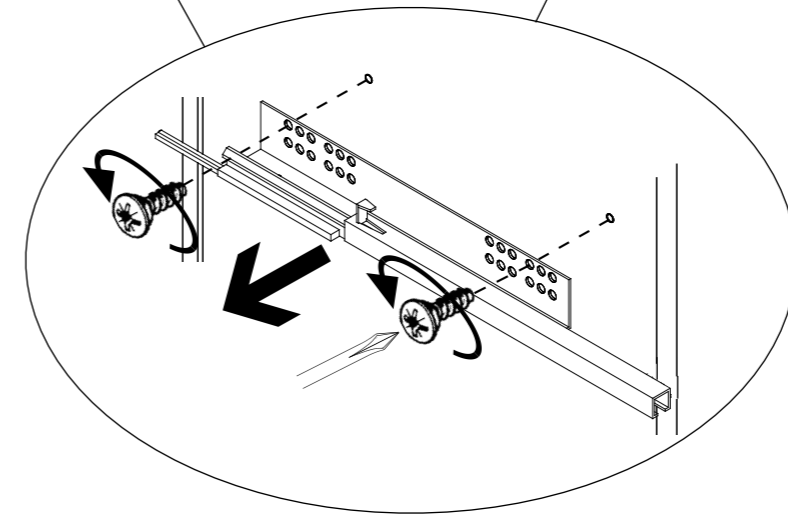
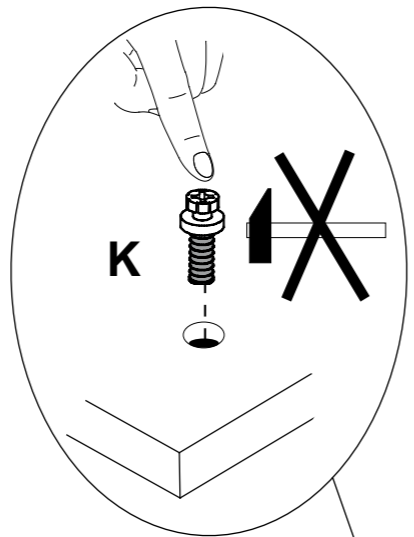
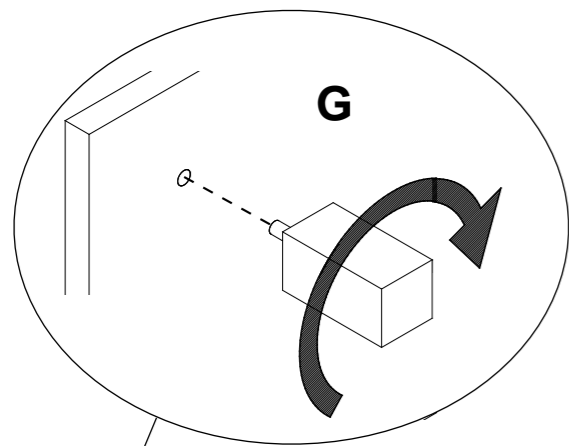
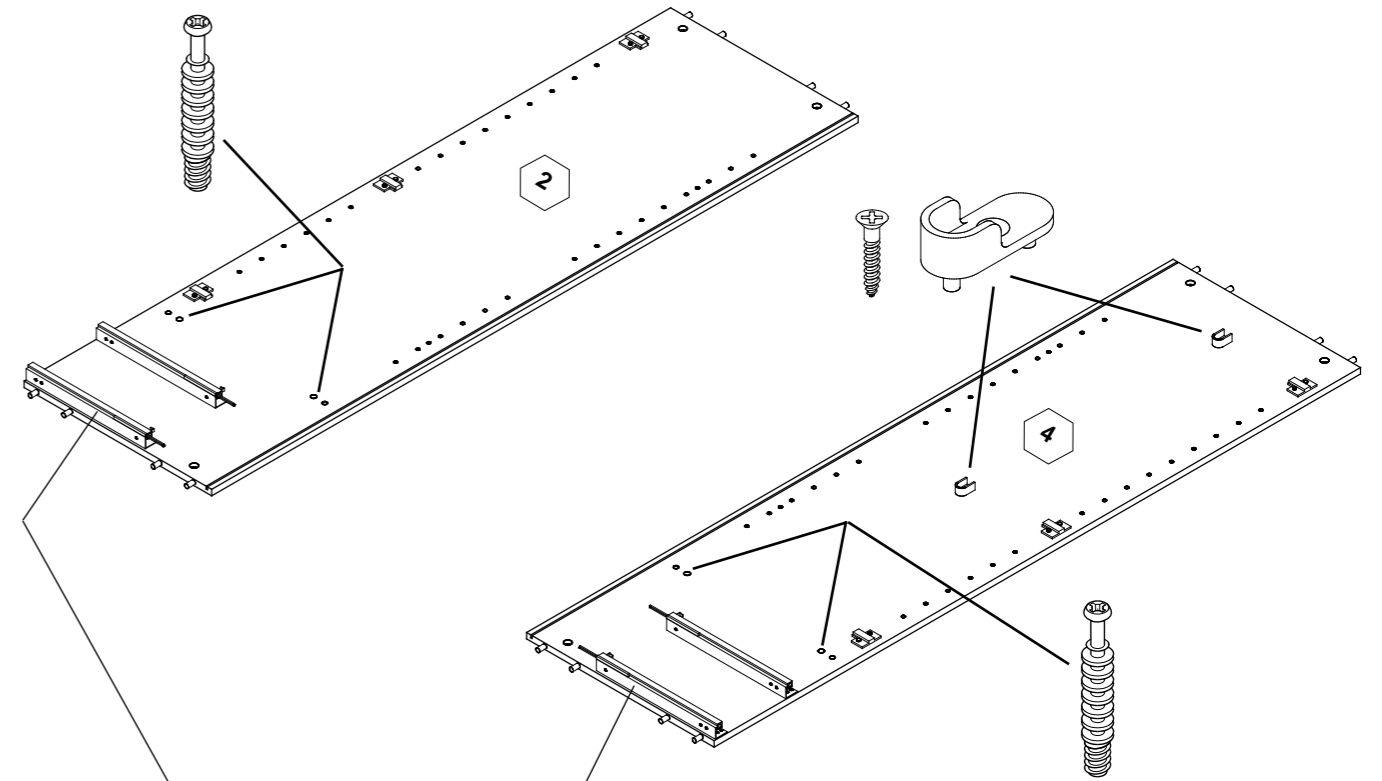
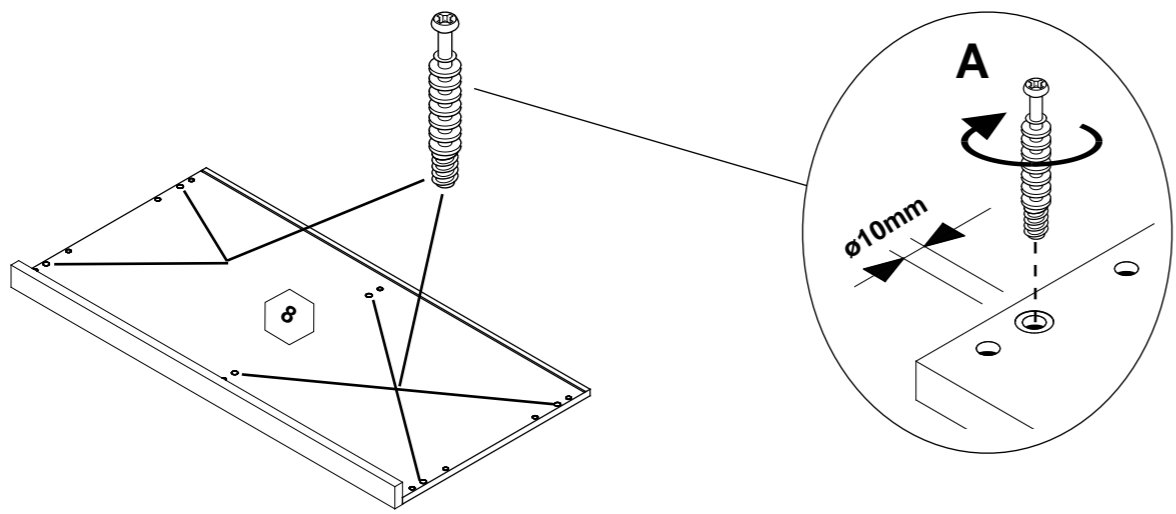

1

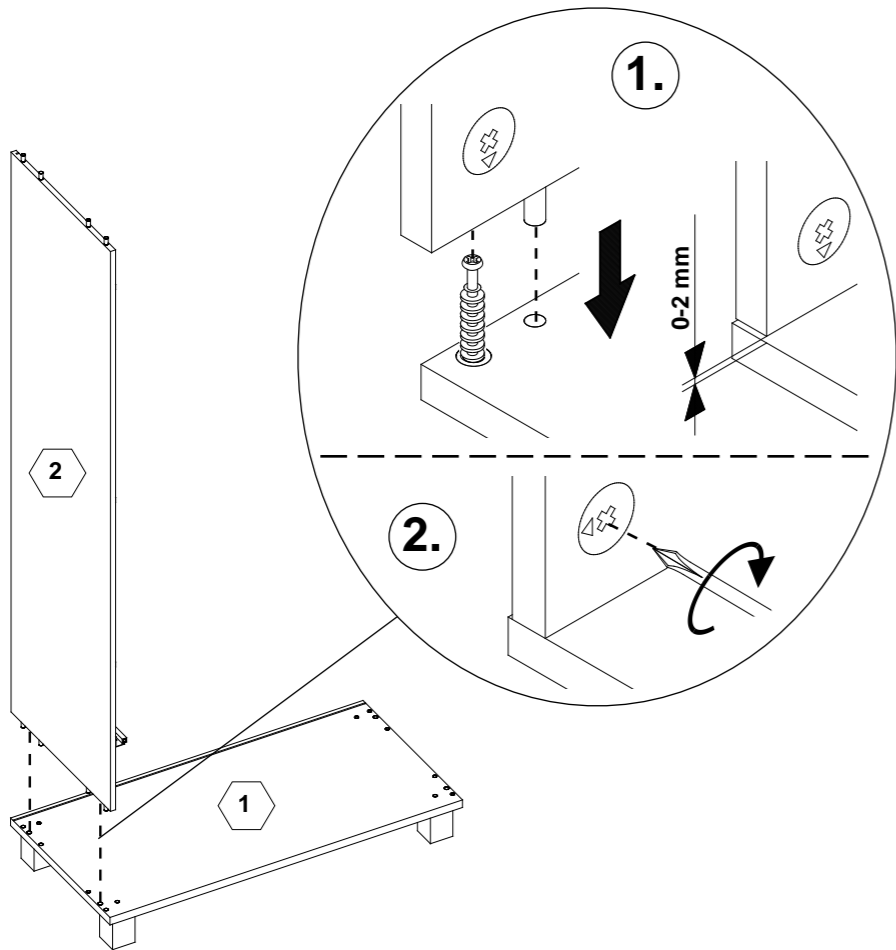

2

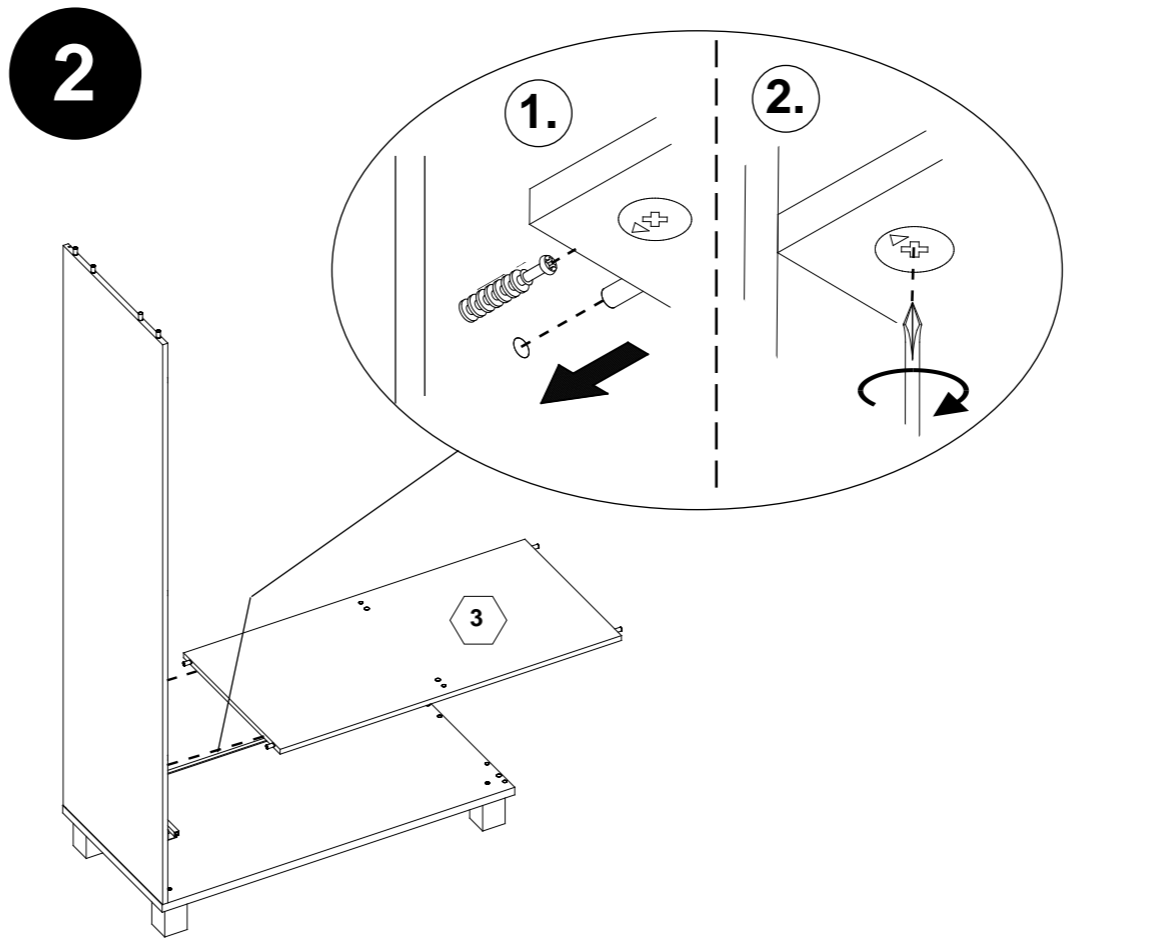

3

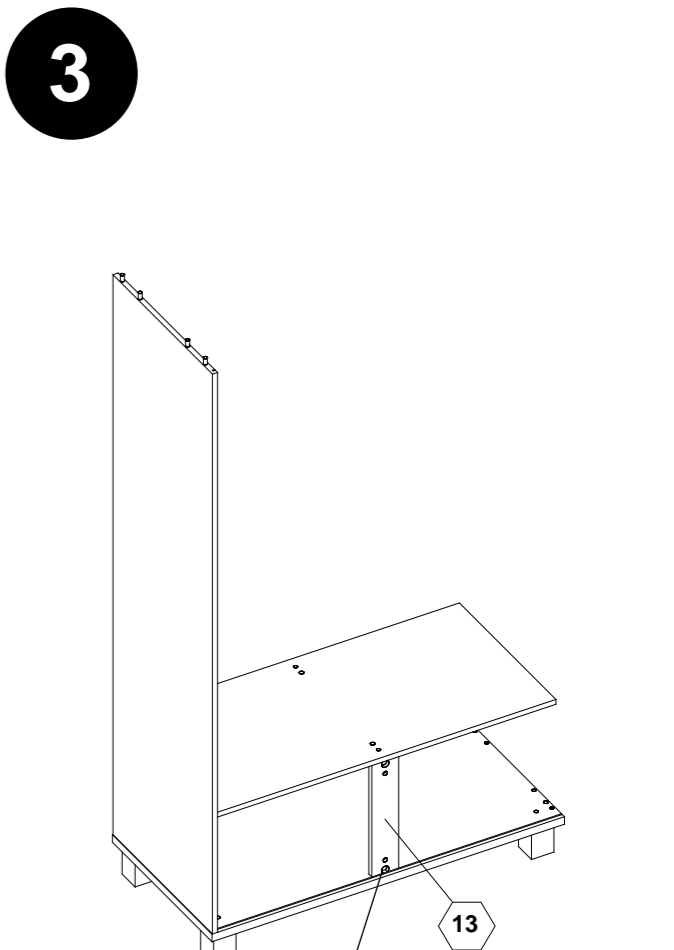

4

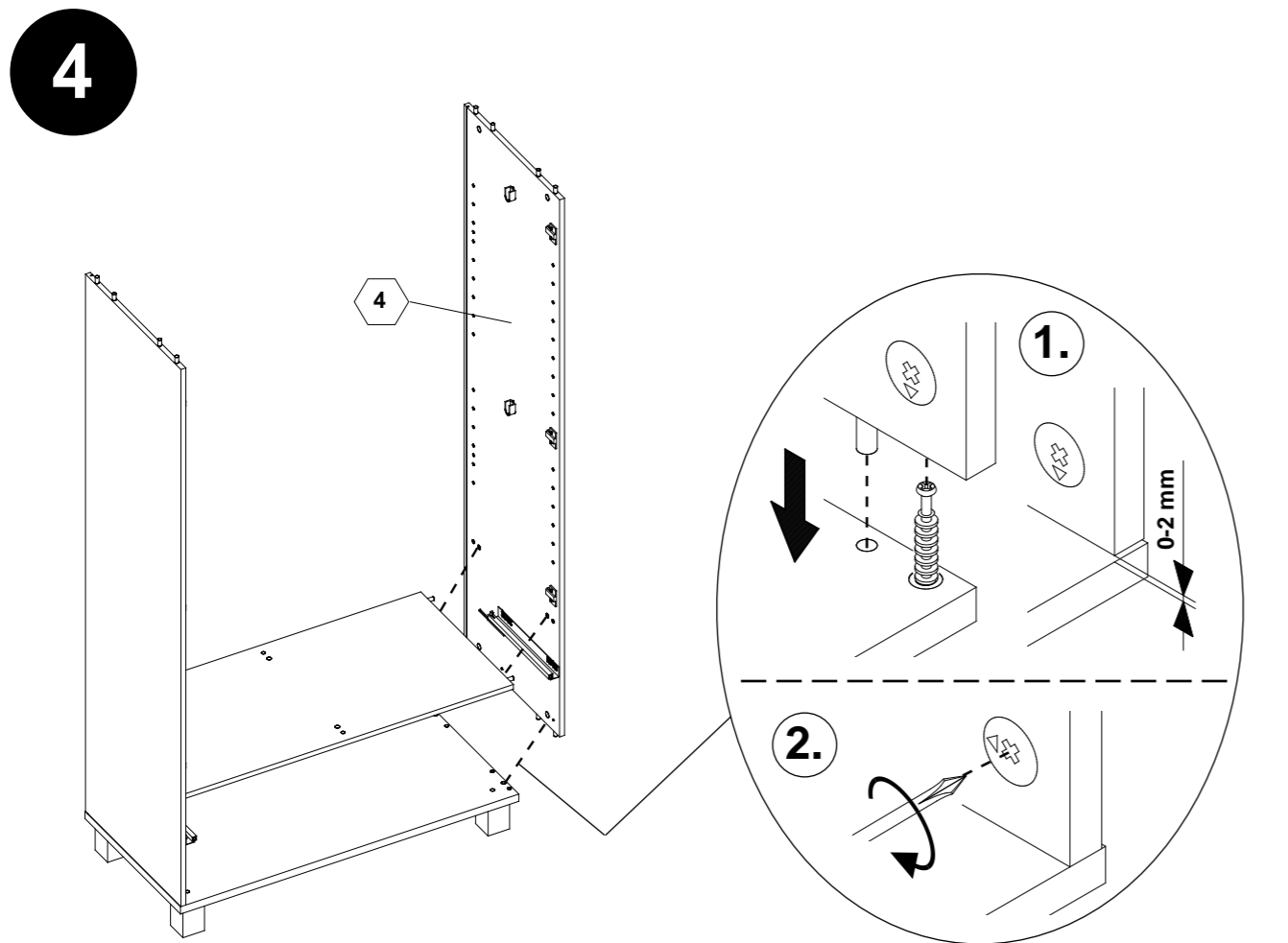

5

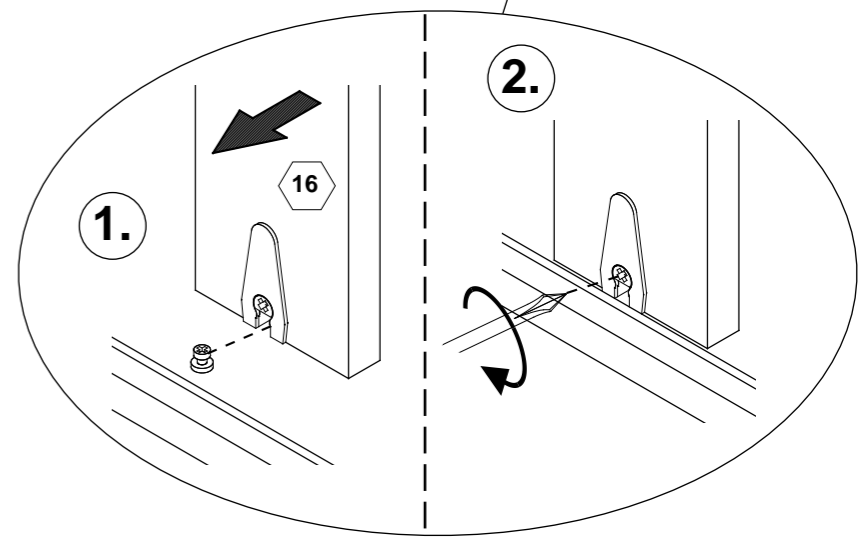
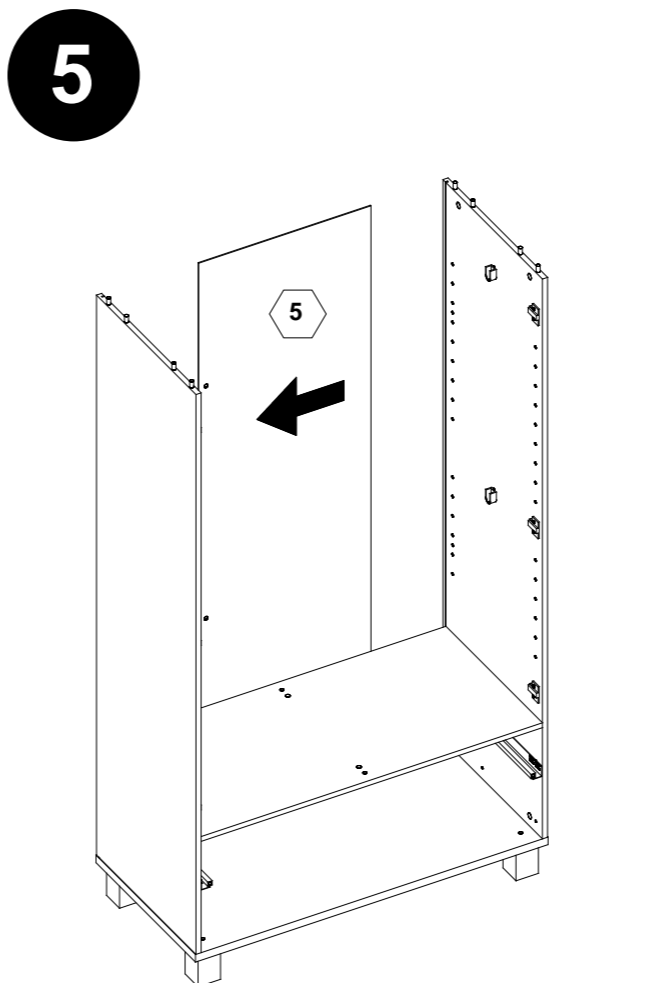

6

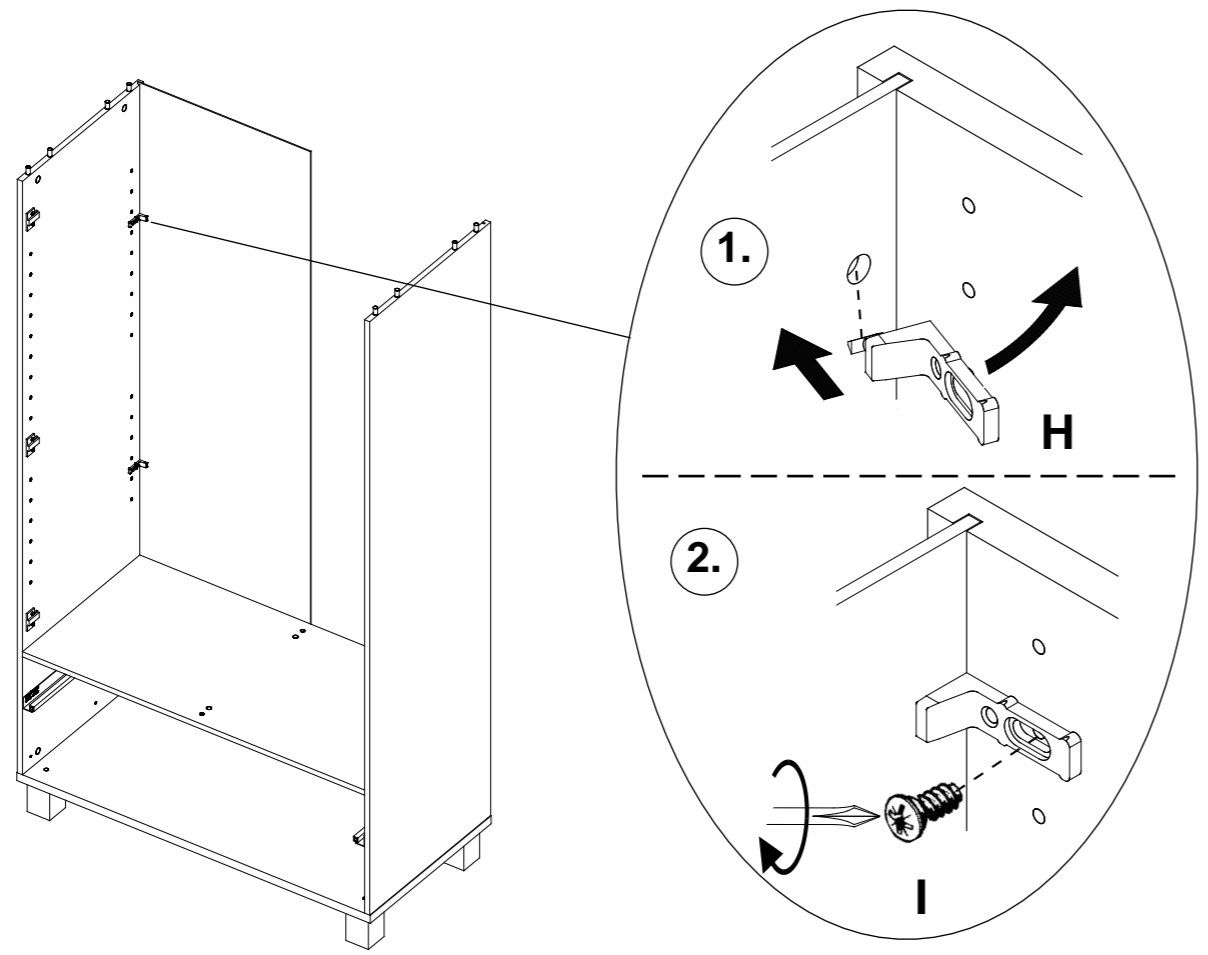

7

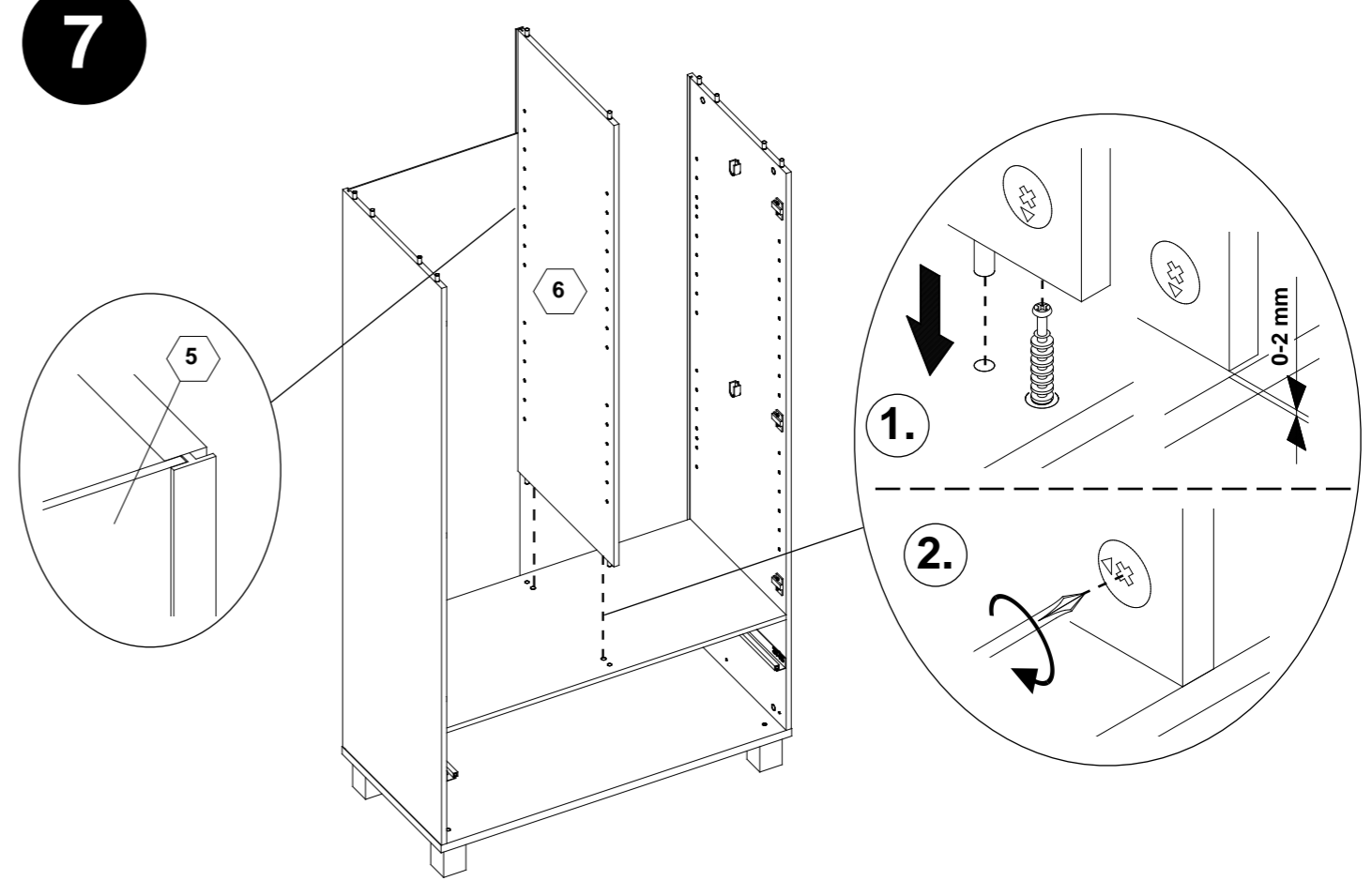

8

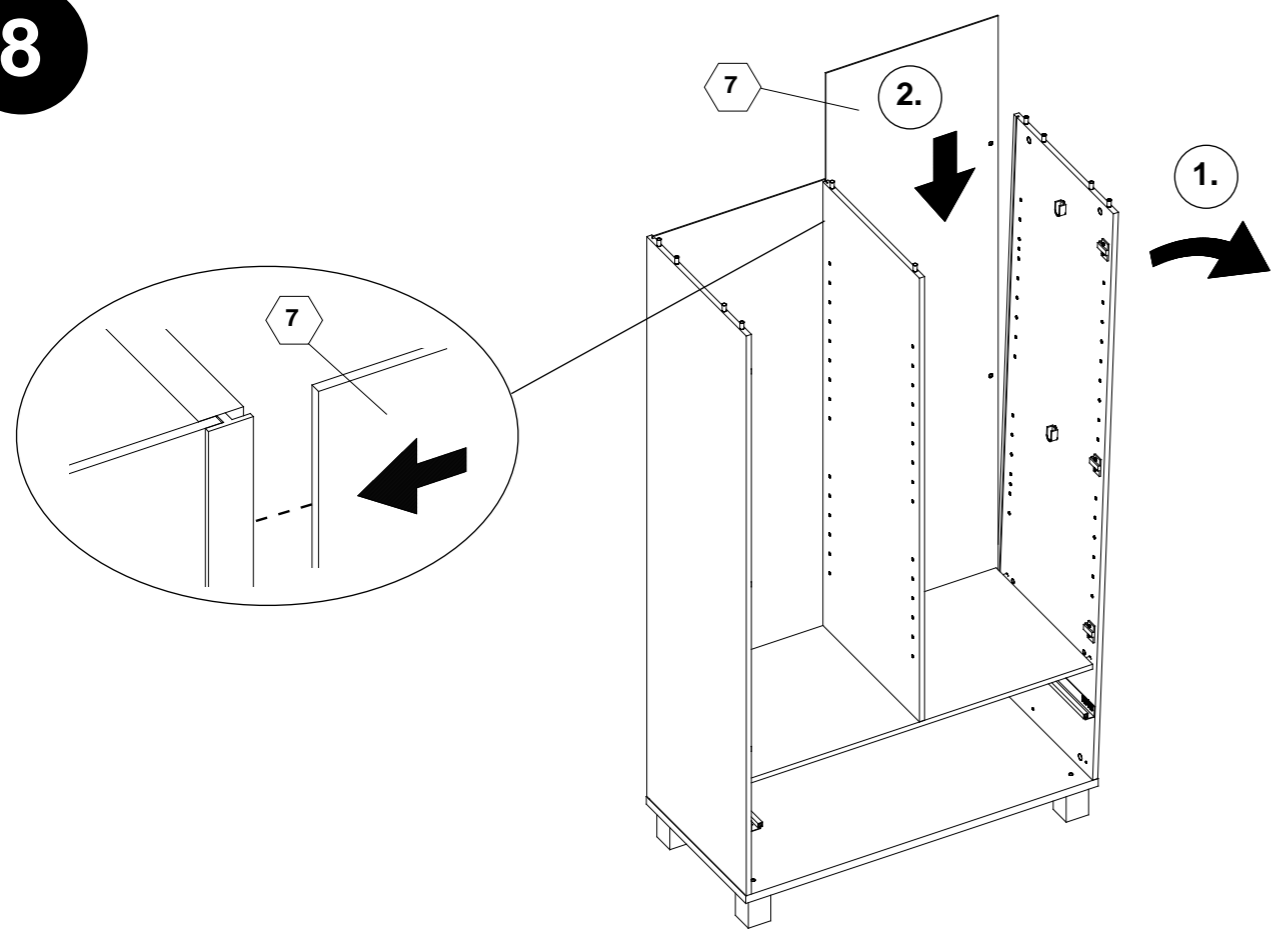

9

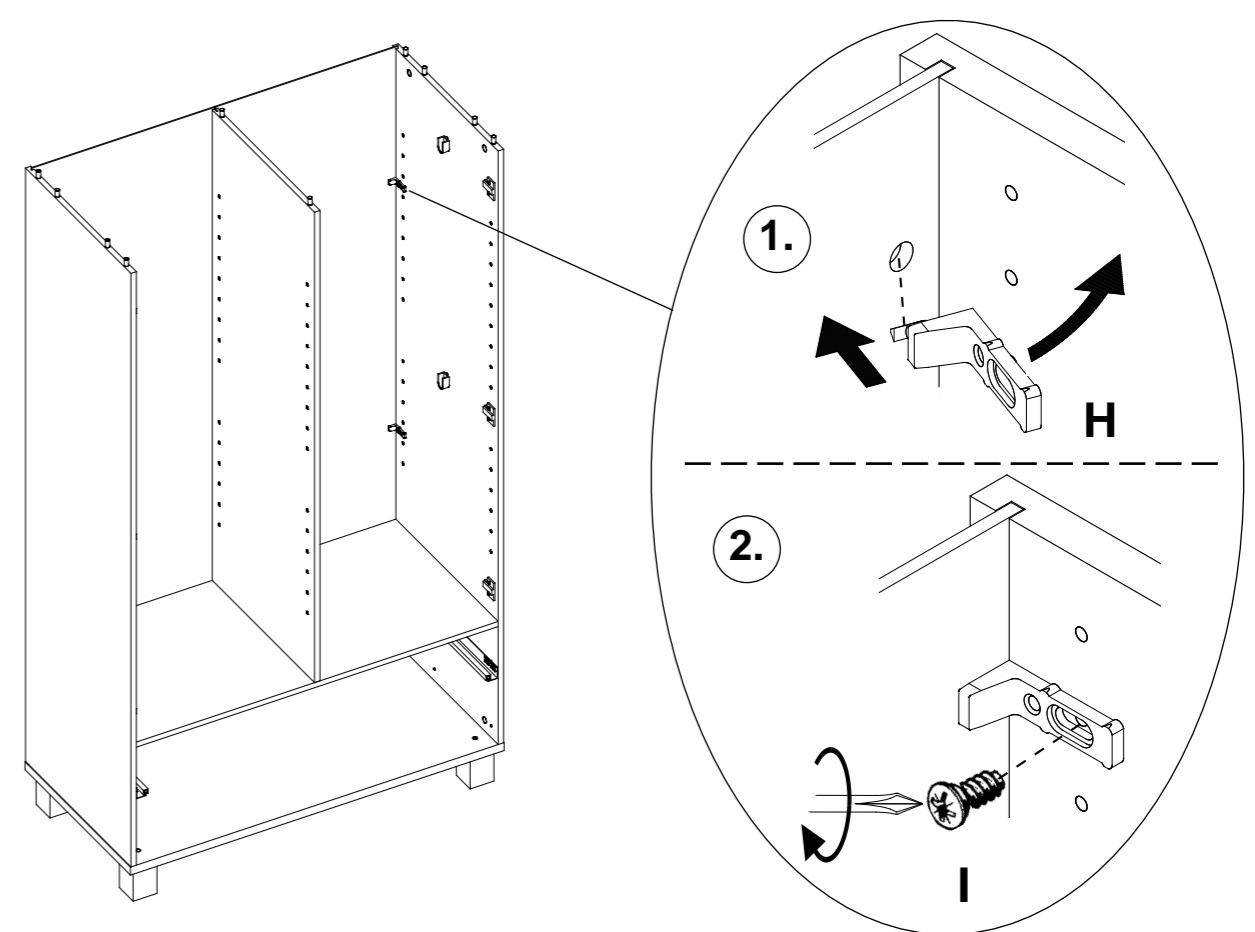

10

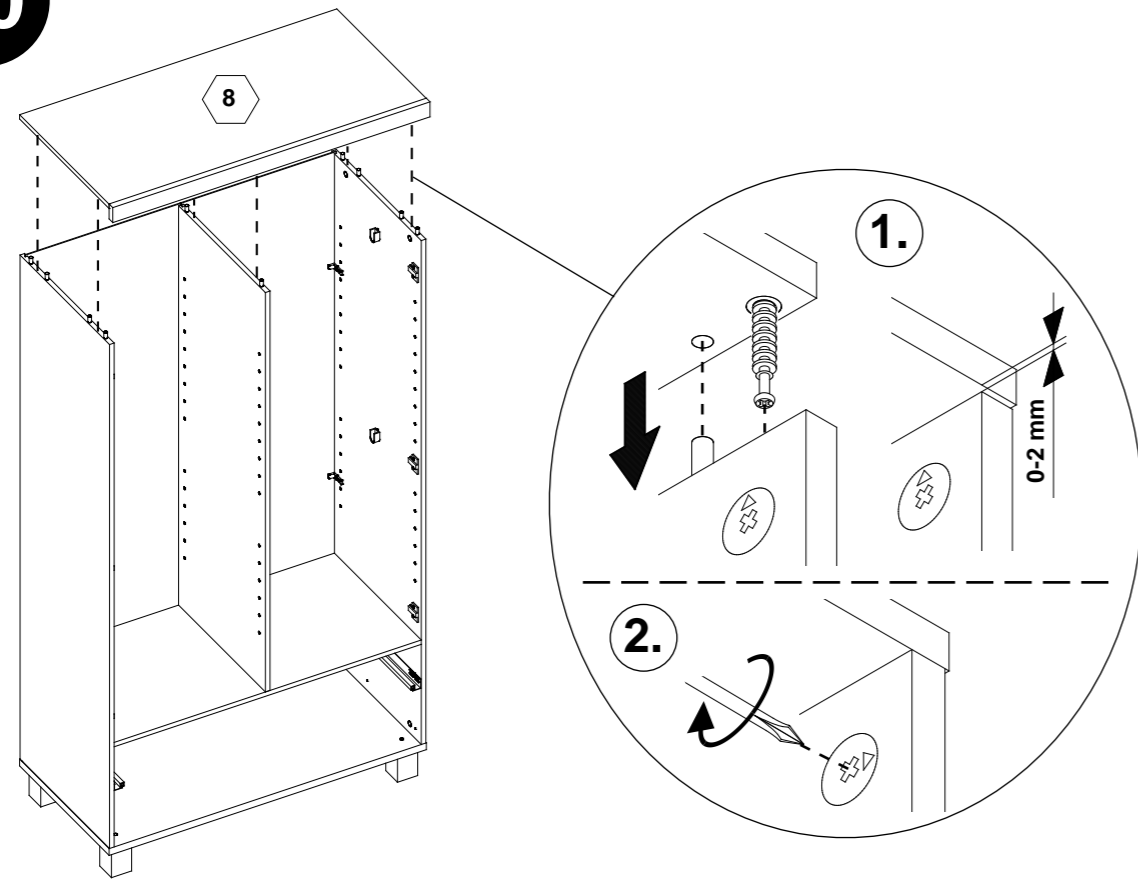

11

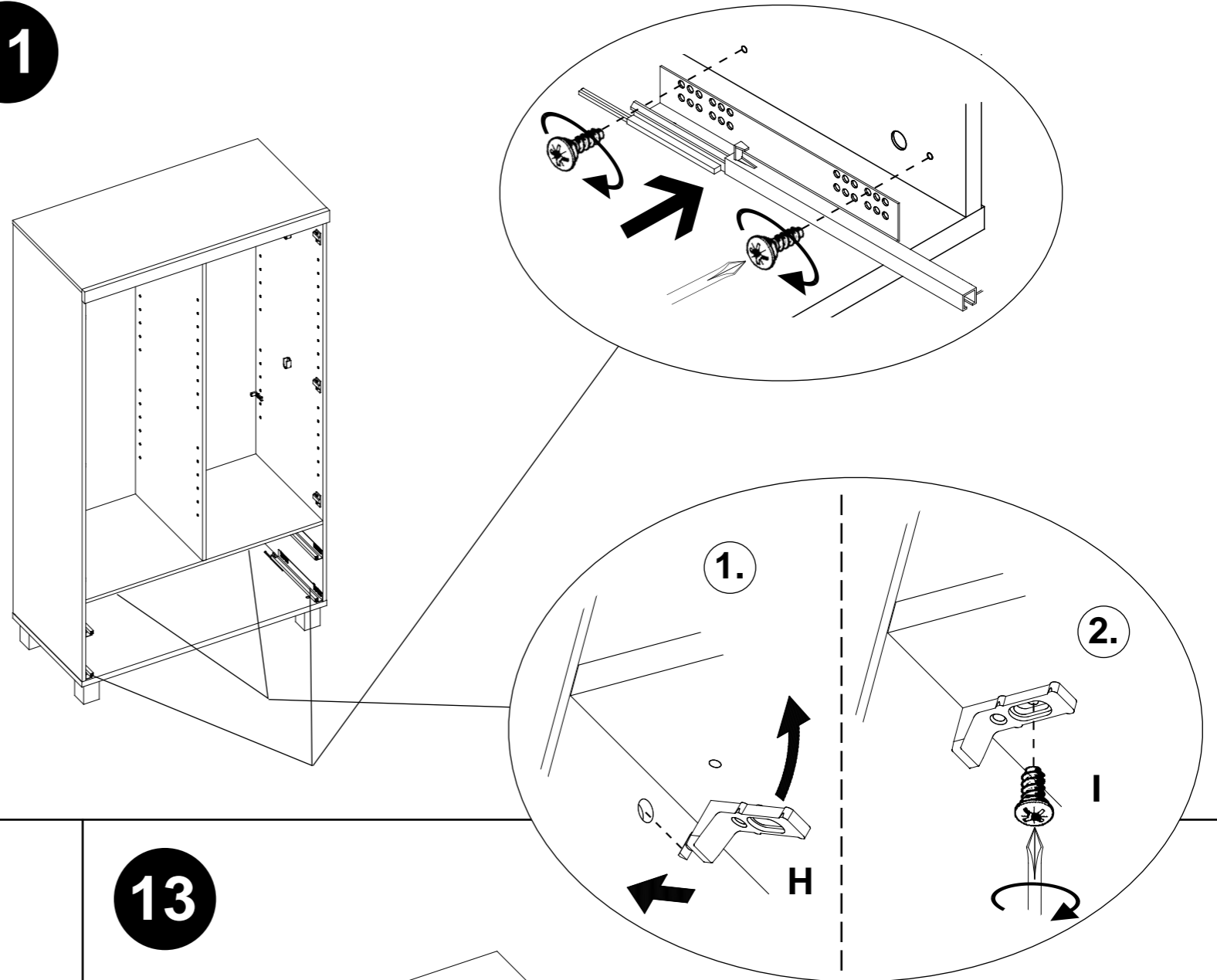

12

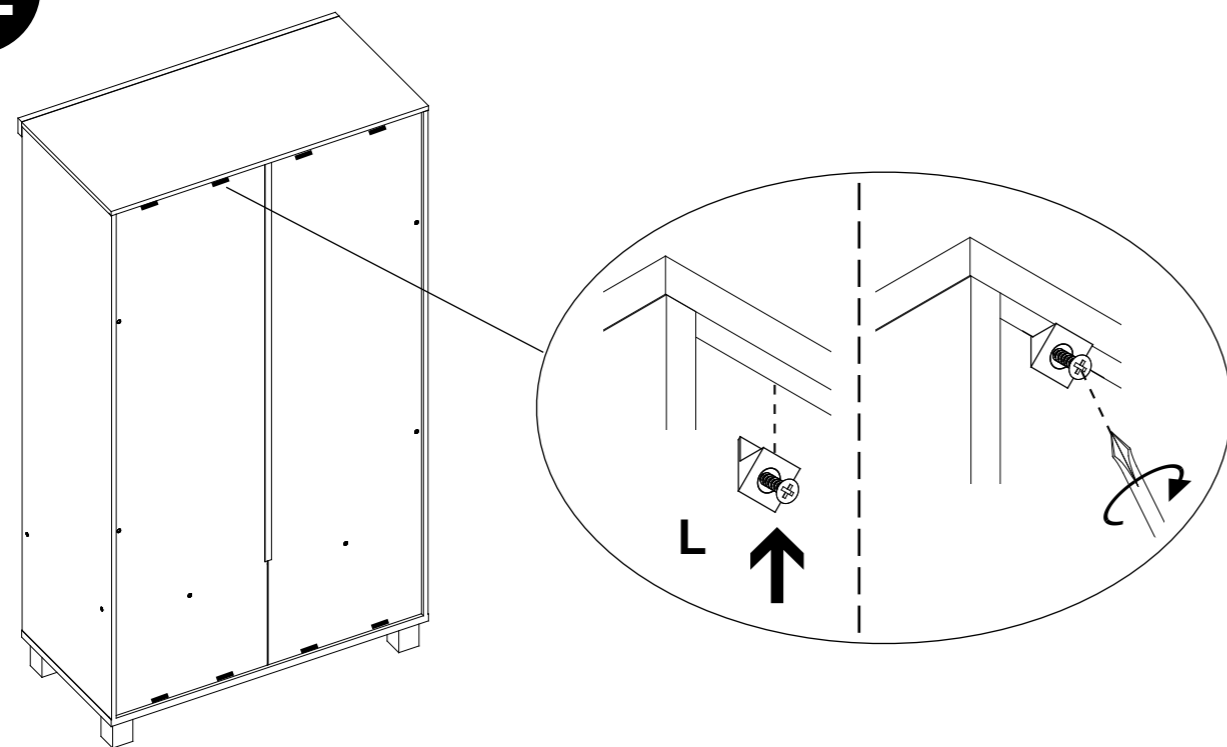

13

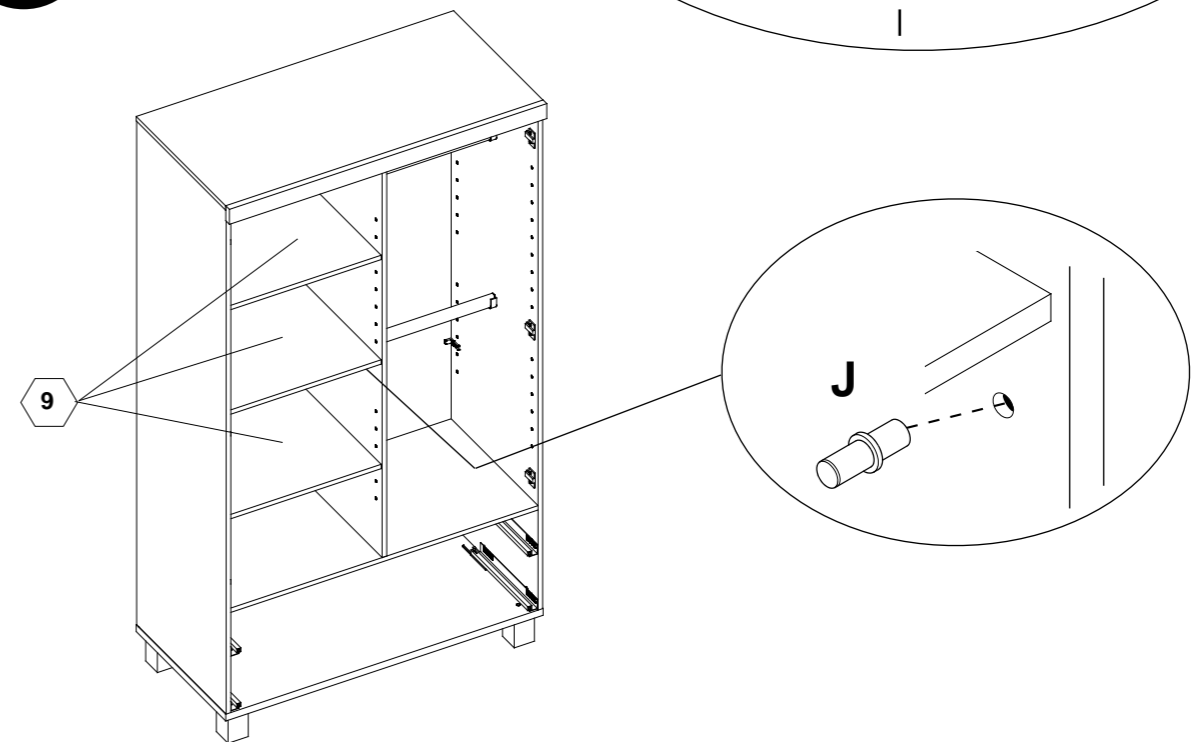

14

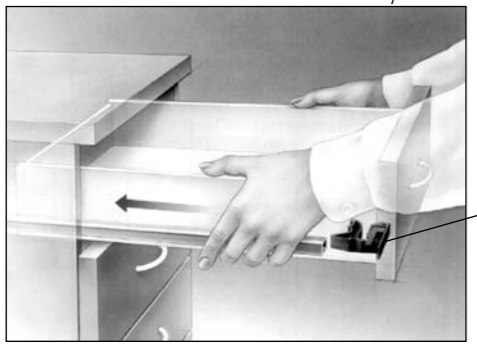
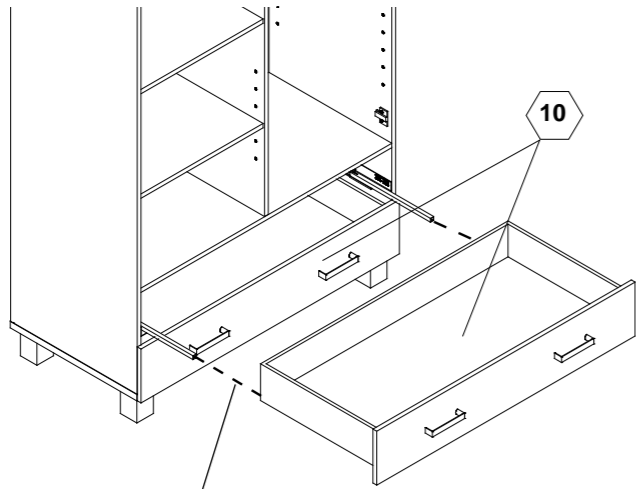

CLICK !!

Justierung der Schubkästen

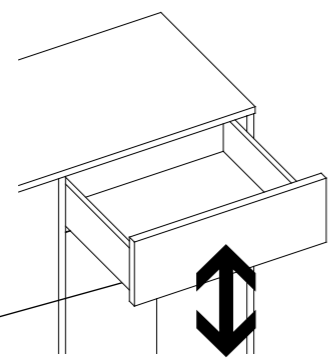
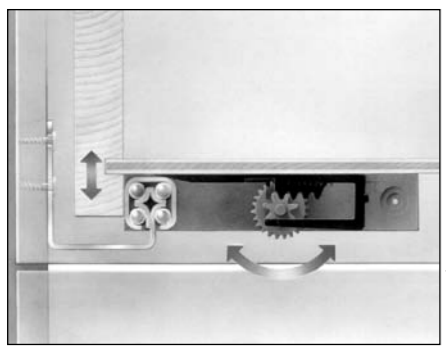
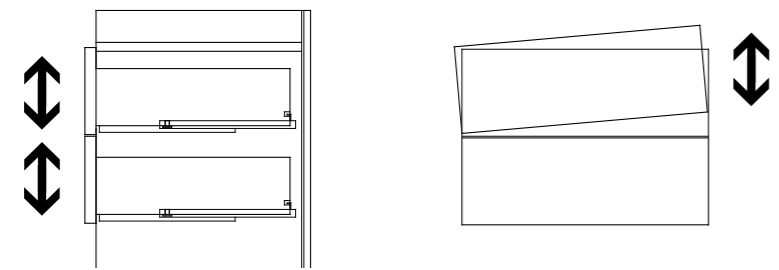

15

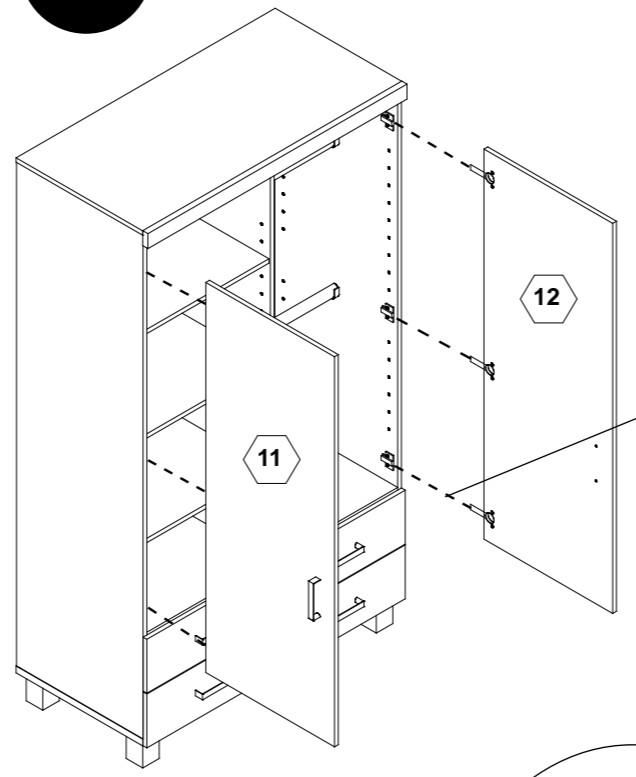

1.

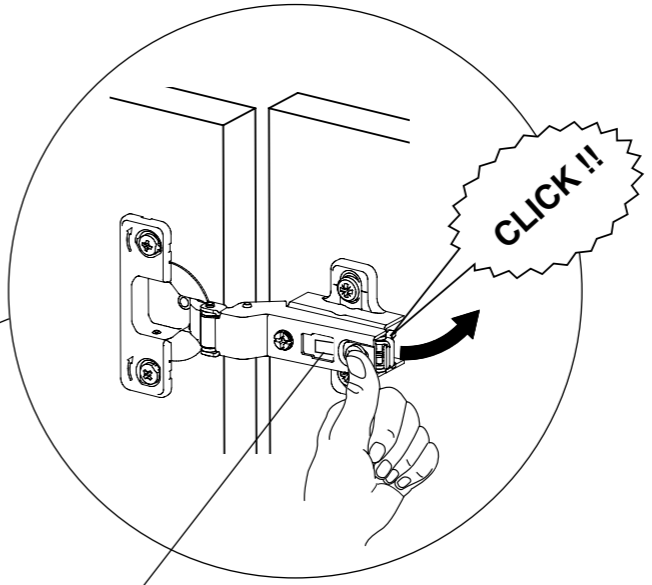

2.

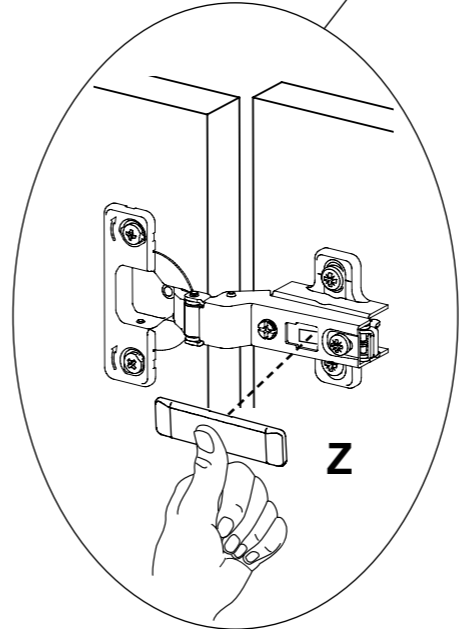

Demontage der Schubkästen

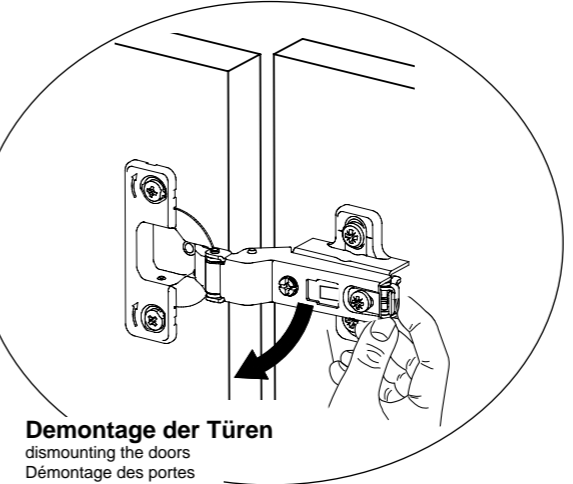
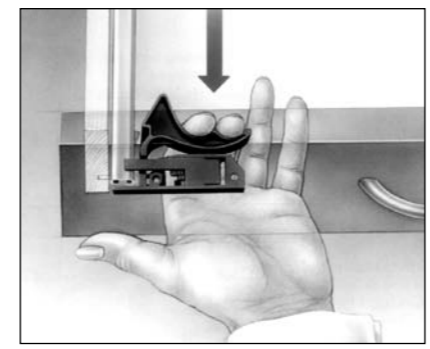

Demontage der Türen  
dismounting the doors  
Démontage des portes  
demontage van de deuren  
Desmontaje de las puertas

Justierung der Türen  
Adjustement of doors  
Ajustement des portes  
Uitlijnen van de deuren  
Ajuste de las puertas

