

**Gebrauchsanleitung PK-Nr. 2706**  
Instructions / Mode d'emploi / Gebruiksaanwijzing /  
инструкция по использованию

PAIDI Möbel GmbH  
Hauptstraße 87  
D-97840 Hafenlohr

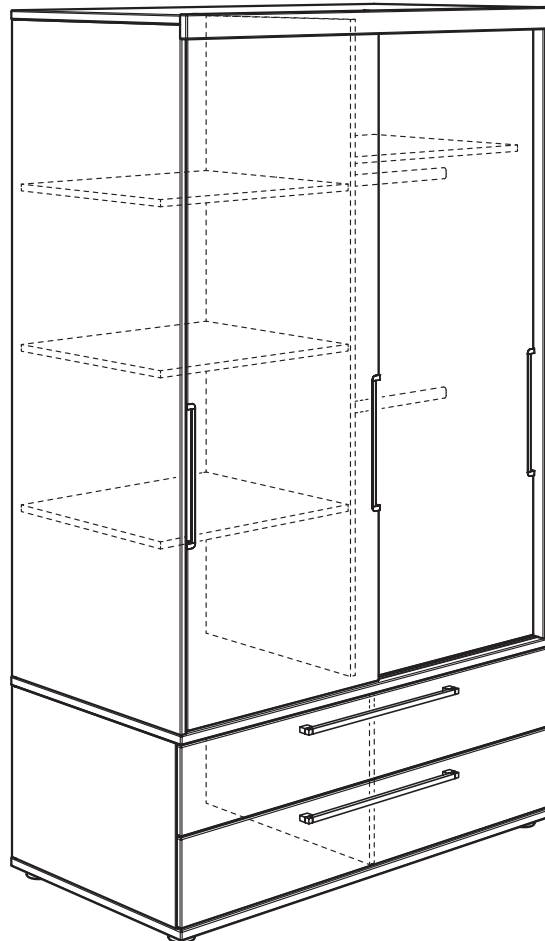

Kinderwelten



**FIONN**  
**131 1011**  
**131 1014**  
**131 1017**

**MATHEA**  
**125 1091**  
**125 1098**



[www.blauer-engel.de/uz38](http://www.blauer-engel.de/uz38)

- emissionsarm
- Holz aus nachhaltiger Forstwirtschaft
- in der Wohnumwelt gesundheitlich unbedenklich



GÜTEZEICHEN



Möbel

# Warnhinweis!

Warning notice! / Avertissement! / Waarschuwing! /  
Предупреждение!

PAIDI Möbel GmbH

Hauptstraße 87  
D-97840 Hafenhöhr



Kinderwelten

V..

Vorbereitung / Preparation / La  
préparation/ Voorbereiding /  
подготовка

M..

Montage / Assembly /  
Assemblage / Bijeenkomst /  
МОНТАЖ

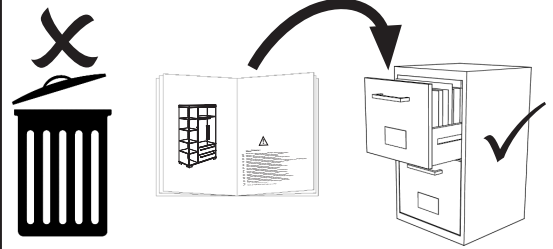

siehe PK-Nr. 2800

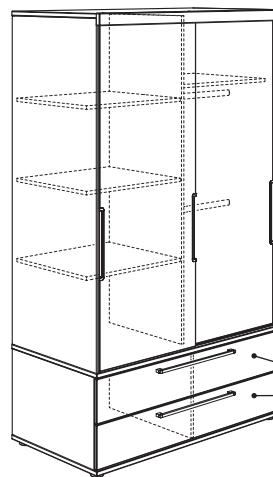

max.  
15 Kg

## Warnhinweis !

- DE Warnhinweis ! Beiliegende Wandbefestigungen müssen montiert werden !  
FR Attention ! Les fixations murales ci-jointes doivent être montées !  
GB Attention ! The enclosed wall mountings must be fitted !  
NL Let op ! De meegeleverde wandbevestigingen moeten worden gemonteerd !  
ES ¡Atención! Las fijaciones murales incluidas deben montarse  
GR Προσοχή ! Τα εξαρτήματα στήριξης που περιλαμβάνονται στη συσκευασία πρέπει να συναρμολογηθούν !  
IT Attenzione ! Occorre montare i fissaggi per attacco alla parete qui allegati !  
CZ Pozor ! Přiložené úchytky musí být namontovány na stěnu !  
SL Pozor ! Namontirati je potrebno priložene elemente za pritrditev na zid !  
PL Uwaga ! Załączone zamocowania do ściany muszą być zamontowane !  
BG Внимание ! Приложените закрепвания за стена трябва да бъдат монтирани !  
HR Pozor ! Priložena zidna pričvršćenja moraju biti montirana !  
LT Dėmesio ! Priededamas tvirtinimo prie sienos detales reikia sumontuoti !  
RU Внимание ! Обязательно используйте прилагаемые крепления стене !  
CN 注意！ 附带的墙壁安装组件必须安装！  
AR تنبه! لا بد من تركيب الأدوات المرفقة للتثبيت على الحائط!

- DE Pflegehinweis: Zum Reinigen der Oberflächen ein leicht-feuchtes Tuch oder ein handelsübliches Möbelpflegemittel verwenden.  
FR Indication sur l'entretien : pour nettoyer les surfaces, utiliser un chiffon légèrement humide ou un nettoyant pour meubles en vente dans le commerce  
GB Caring for the... : In order to clean the surfaces please use a slightly damp cloth or commercially available furniture care product.  
NL Verzorgingsanwijzing: Voor het reinigen van de oppervlakken een licht vochtig doek of een gebruikelijk meubelschoonmaakmiddel gebruiken.  
ES Recomendaciones de cuidado: Para limpiar las superficies del mueble debe usar un trapo humedecido o un producto de limpieza de muebles comercial.  
GR Οδηγίες περιποίησης: Για το καθάρισμα των επιφανειών να χρησιμοποιείτε ένα ελαφρά νοτισμένο πανάκι ή λούστρο επίπλων.  
IT Indicazione per pulizia e cura: Per la pulizia delle superfici utilizzate un panno leggermente umido o un normale prodotto per la cura dei mobili.  
CZ Pokyny k čištění: Na čištění povrchu použijte pouze navlhlý kousek látky nebo běžný prostředek na ošetřování nábytku.  
SL Navodilo za nego: Za čiščenje površin uporabljajte malo vlažno cunjo ali trgovsko običajno sredstvo za nego pohištva.  
PL Wskazówka pielęgnacyjna: do czyszczenia powierzchni stosować lekko wilgotną ściereczkę lub zwykły środek do pielęgnacji mebli.  
BG Указание за поддръжане: Използвайте леко навлажнена кърпа или обикновен препарат за поддръжане на мебели, за да почистите повърхностите.  
HR Upute za njegu: Za čišćenje površina upotrijebiti jednu lako navlaženu krpu i trgovačko uobičajeno sredstvo za njegu namještaja.  
LT Rekomendacija priežiūrai: Paviršius valykite drėgna pašluoste arba parduotuvėse įsigytomis baldų priežiūros priemonėmis.  
RU Рекомендации по уходу: для очистки поверхностей используйте слегка влажную тряпку или обычное средство по уходу за мебелью.  
CN 保养说明: 清洁表面只需用稍微潮湿的布或普通的家具清洁剂即可。

Seite 2 von 32

PK-Nr. 2706 Stand 01/2017 Ä: 08/2020

# Beschläge

Fittings / Raccords / Fittingen / кованый

PAIDI Möbel GmbH  
Hauptstraße 87  
D-97840 Hafenhof







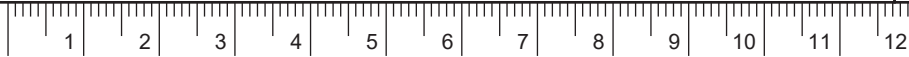



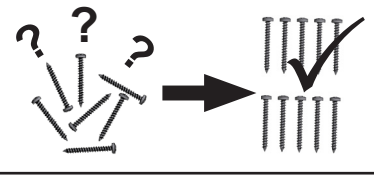

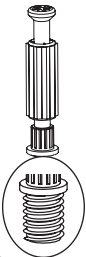

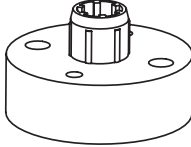

Kinderwelten

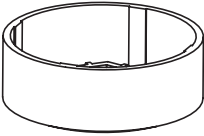
1:1  
DIN A4

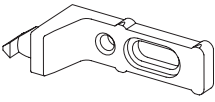

ca. 1,75h

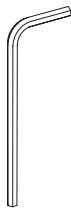
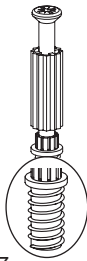

<p><b>A</b></p>  <p>28x 681 0759</p>	<p><b>B</b></p>  <p>4x 681 1645</p>	<p><b>C</b></p>  <p>3,5 x 13 10x 681 4887</p>	<p><b>D</b></p>  <p>16x 681 8126</p>	<p><b>E</b></p>  <p>6x 681 8409</p>	<p><b>F</b></p>  <p>M8 6x 681 8428</p>	<p><b>G</b></p>  <p>6x 681 8408</p>	<p><b>H</b></p>  <p>M8 x 30 6x 681 8427</p>
<p><b>I</b></p>  <p>SW4 1x 681 3011</p>	<p><b>J</b></p>  <p>4x 681 2497</p>	<p><b>K</b></p>  <p>6,3 x 15 4x 681 5060</p>	<p><b>L</b></p>  <p>16x 681 2498</p>	<p><b>O</b></p>  <p>SW1,5 1x 681 3007</p>	<p><b>P</b></p>  <p>SW3 1x 681 3009</p>	<p><b>R</b></p>  <p>3x 681 0757</p>	<p><b>S</b></p>  <p>ø5 x 25 2x 681 0351</p>

**Progr. FIONN**

**Progr. MATHEA**

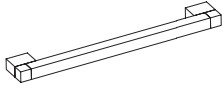
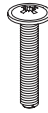
<p><b>M</b></p>  <p>2x 671 8408</p>	<p><b>N</b></p>  <p>M4 x 22 4x 681 3807</p>
---	--

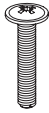
<p><b>M</b></p> <p><b>Griffstange</b></p> <p>Länge: 788mm</p> <p>2x 681 8439</p>	<p><b>N</b></p>  <p>M4 x 22 6x 681 3807</p>
--	--

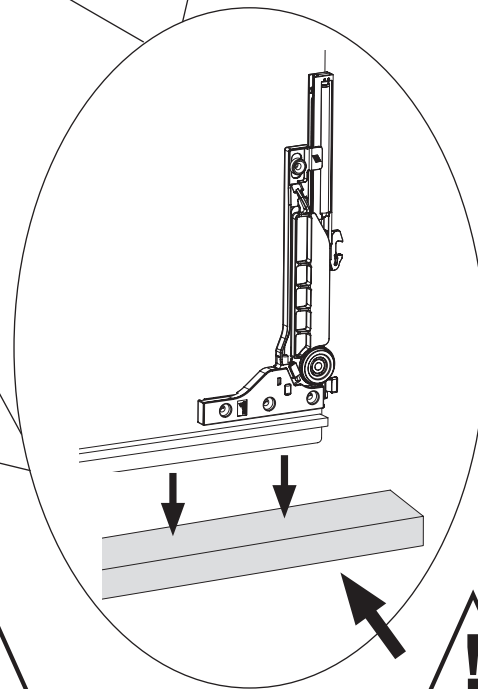
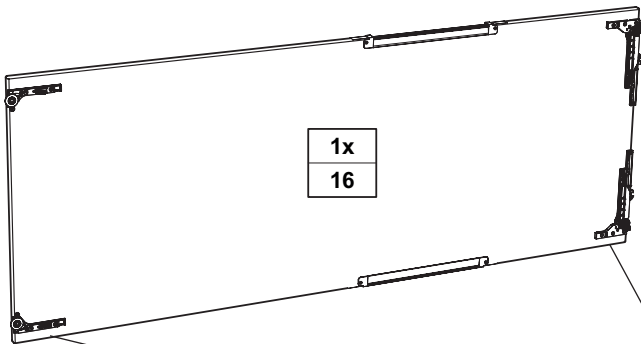
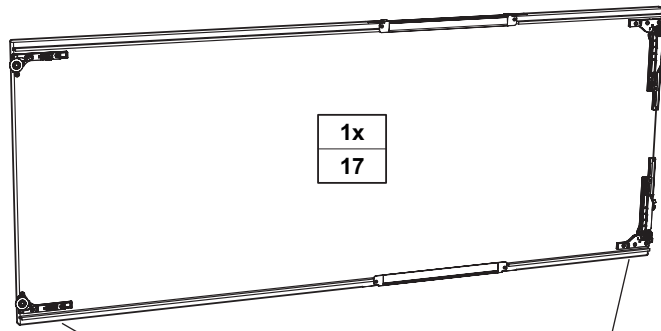

**Stellen sie die Türen nach dem Auspacken mit der Längskante auf die Styroporstreifen !**

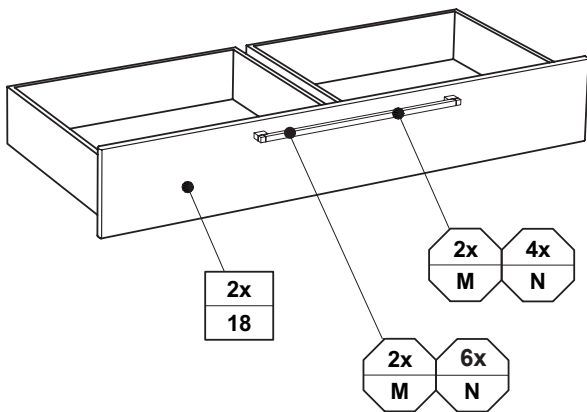

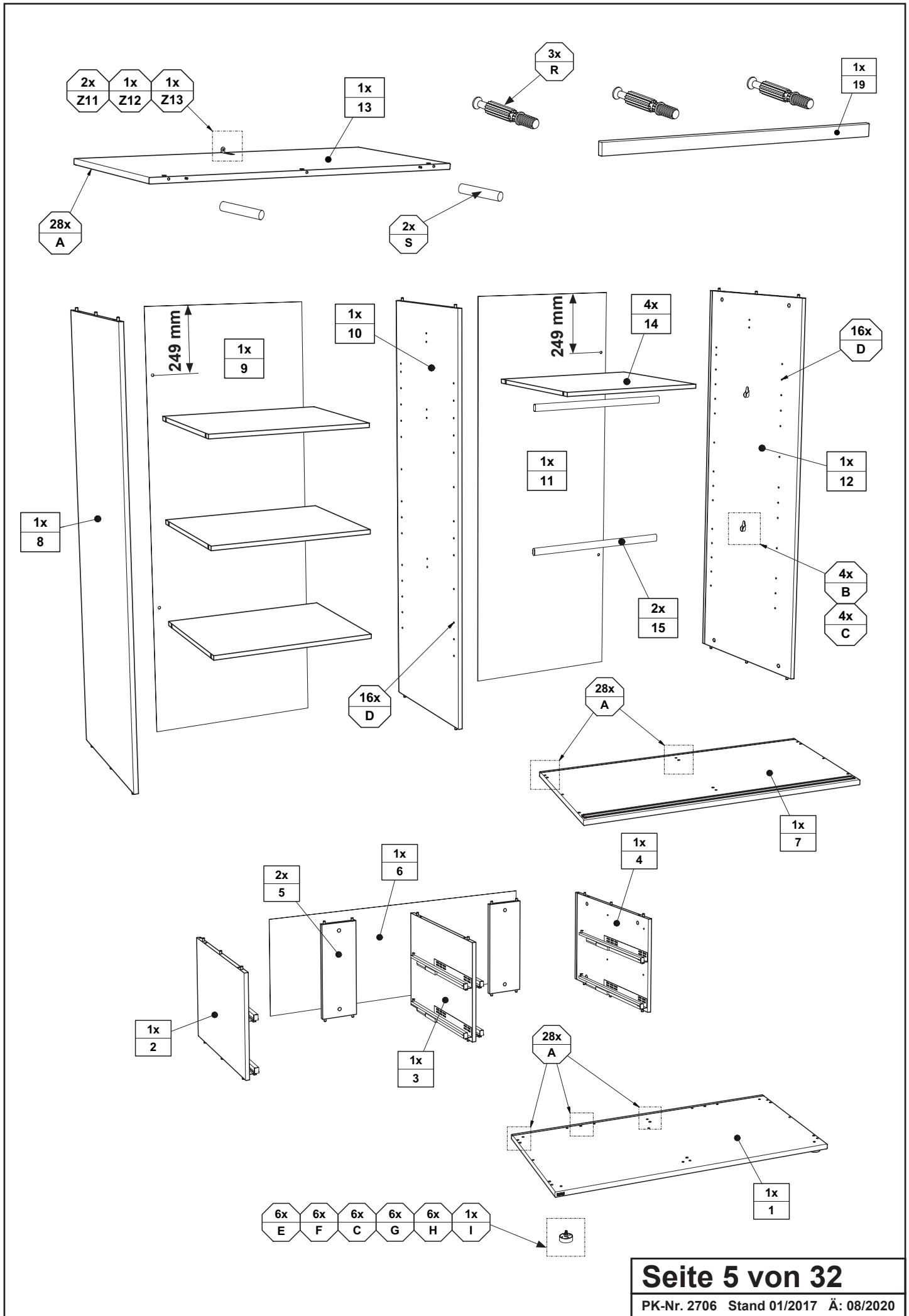

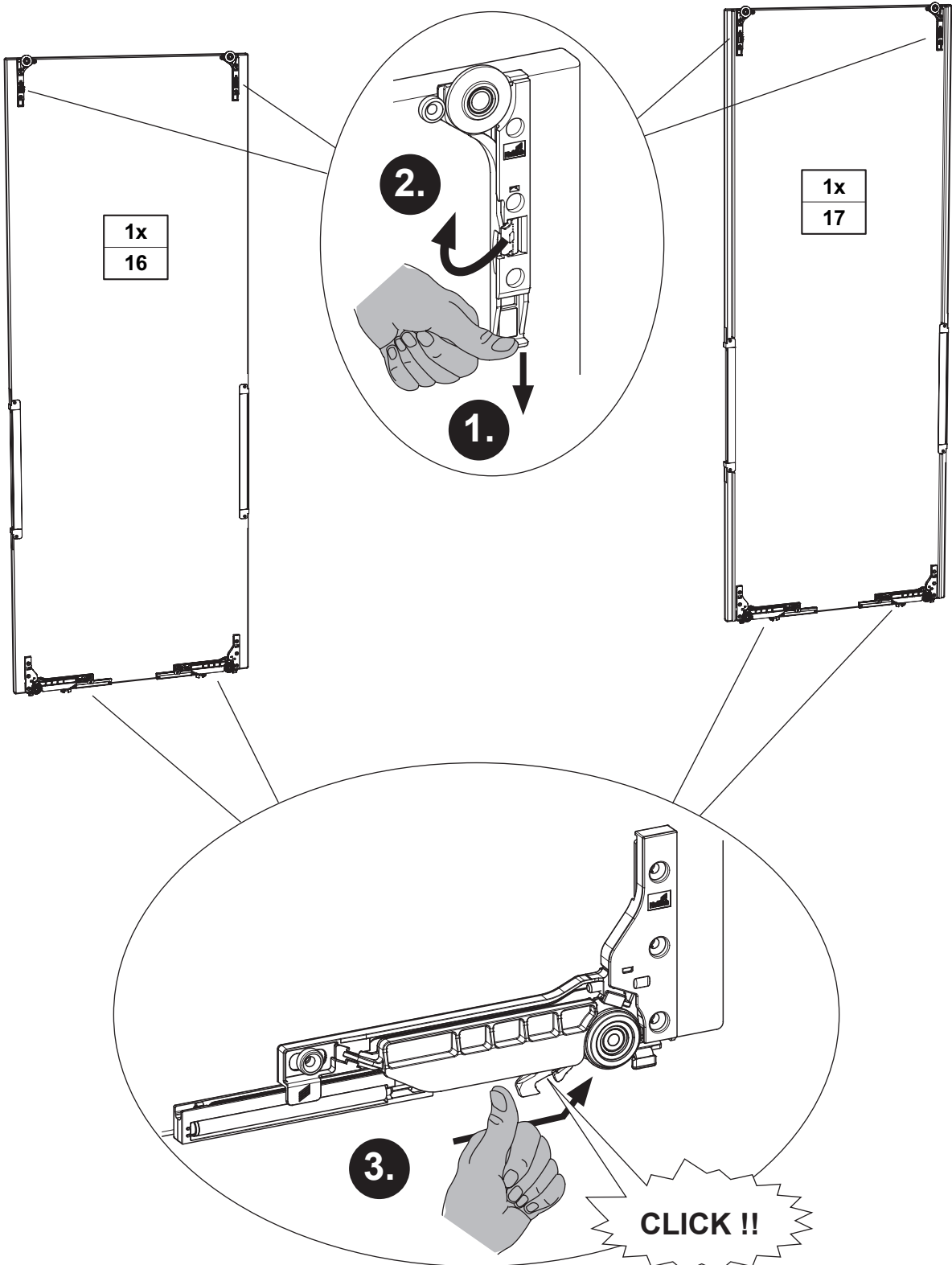

V3

1.

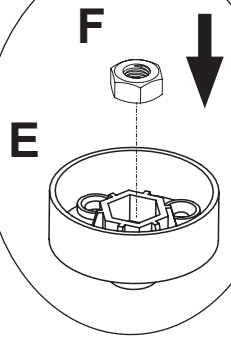

2.

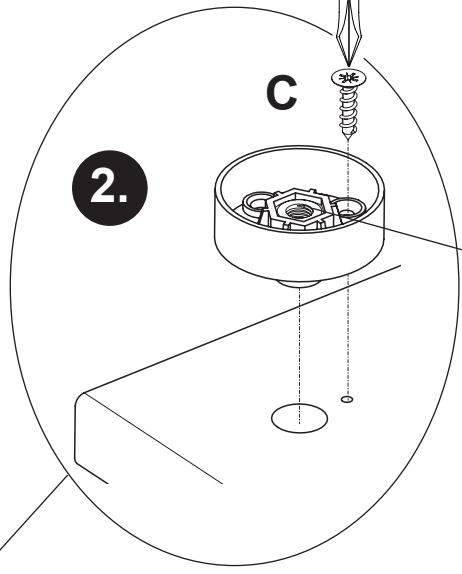

3.

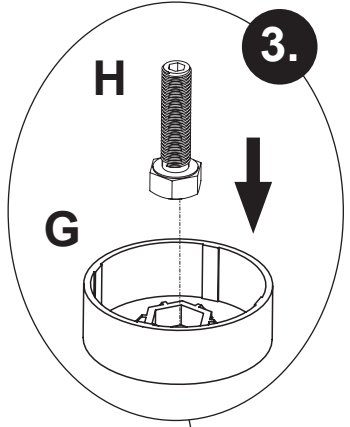

4.

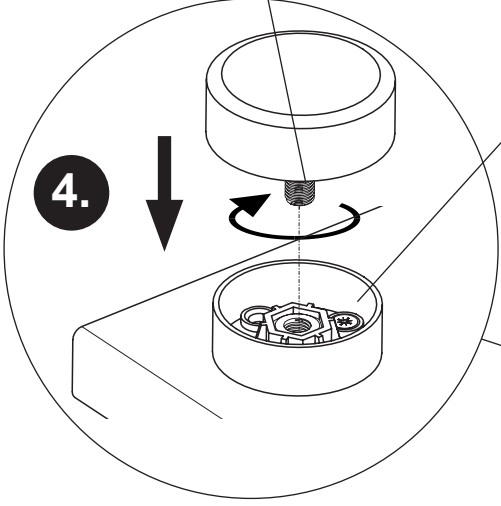

V3.1

- 6x E
- 6x F
- 6x C
- 6x G
- 6x H
- 1x I

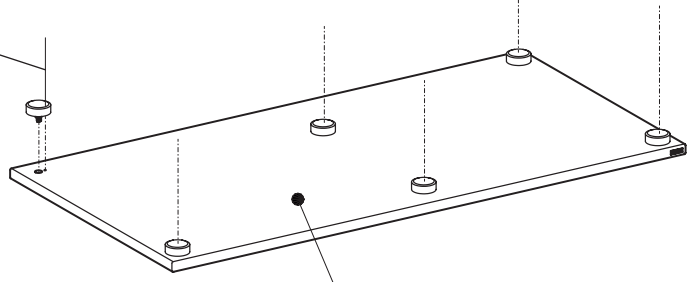

- 1x 1

V3.2

A

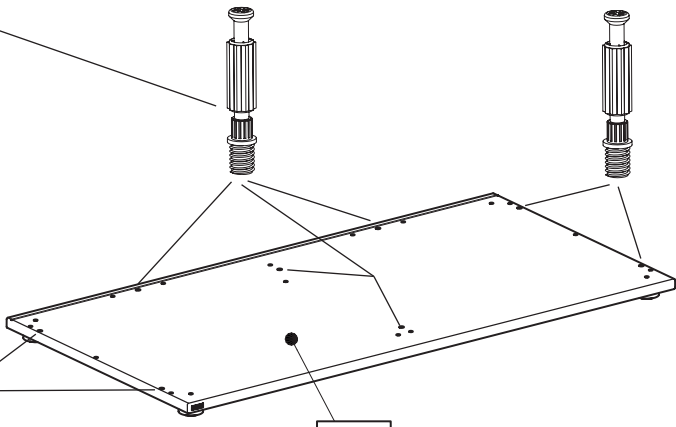
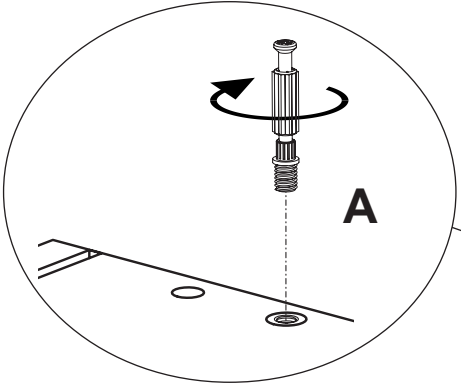

- 1x 1

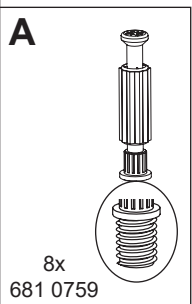

8x 681 0759



3,5 x 13  
6x  
681 4887

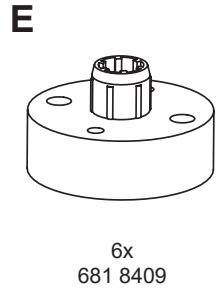

6x  
681 8409

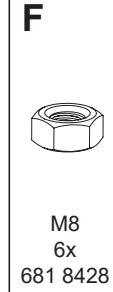

M8  
6x  
681 8428

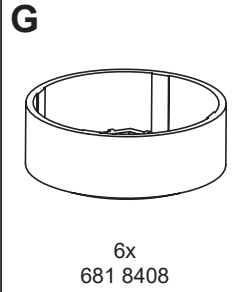

6x  
681 8408

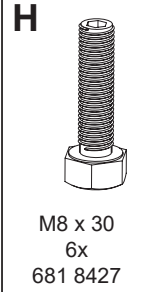

M8 x 30  
6x  
681 8427

# V4

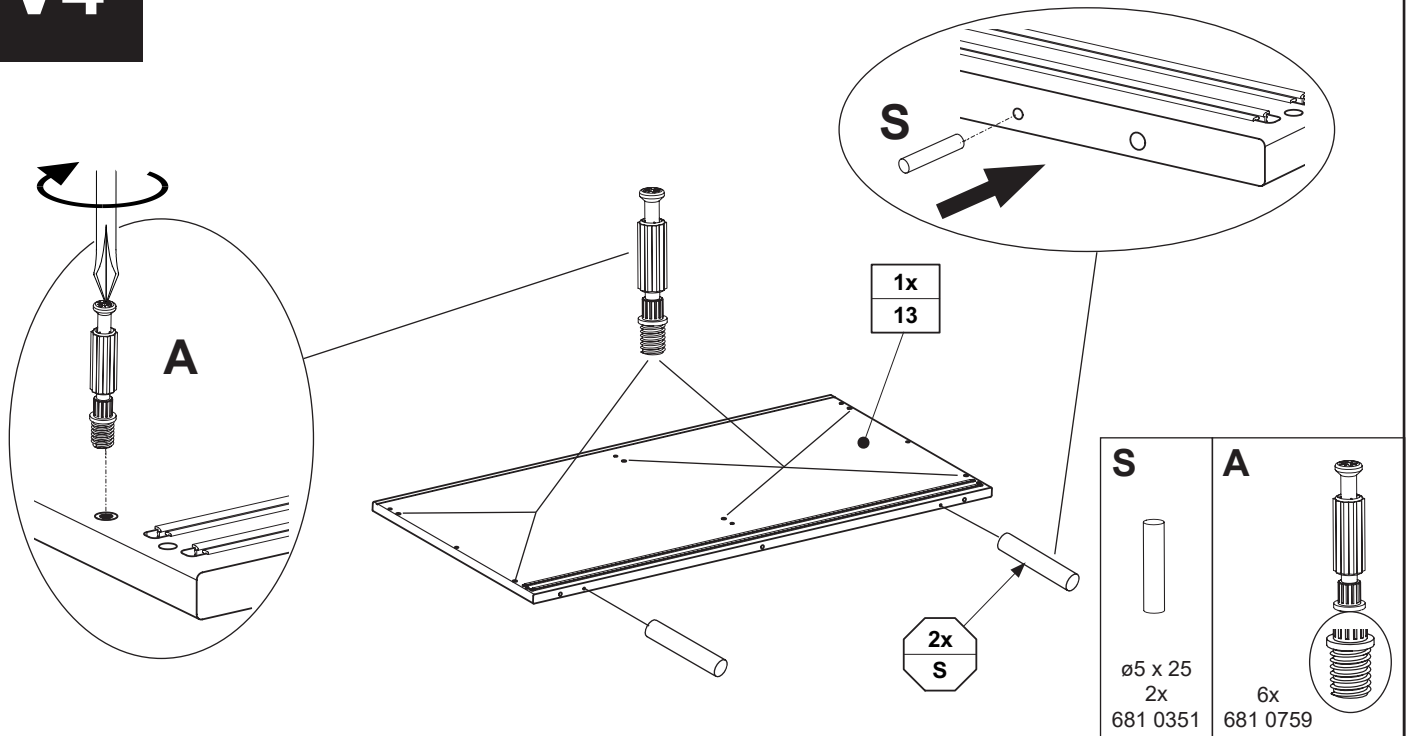

# V5

## V5.1

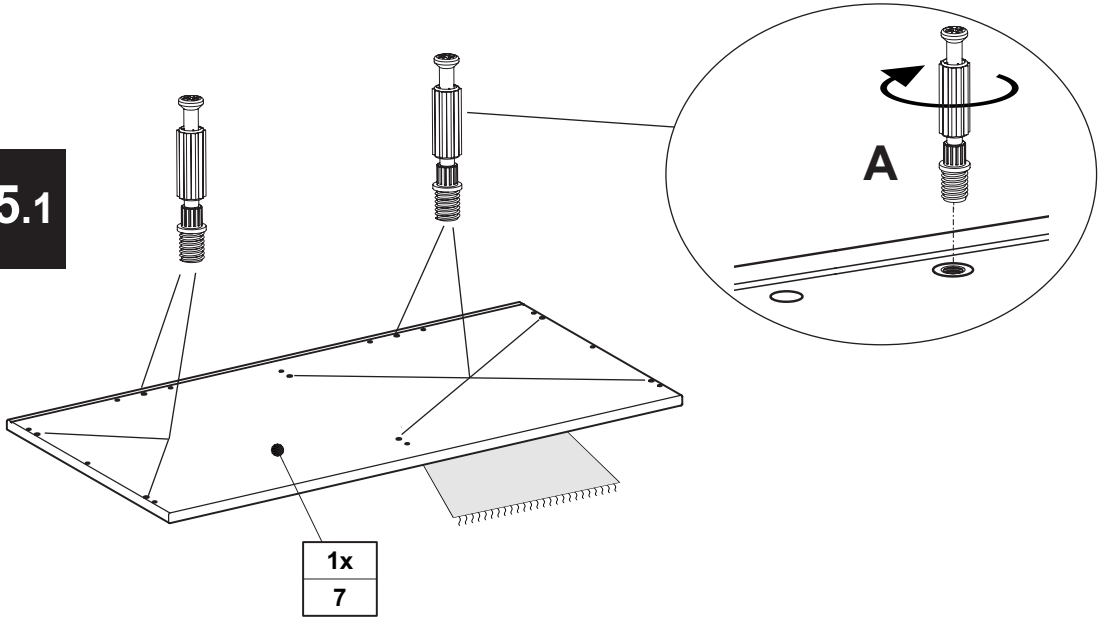

## V5.2

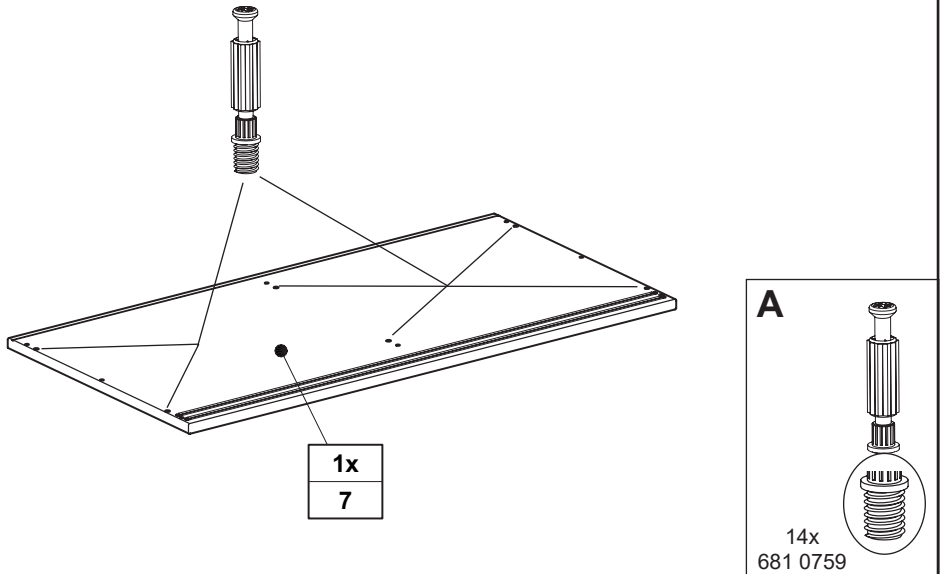



V6

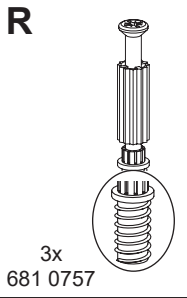
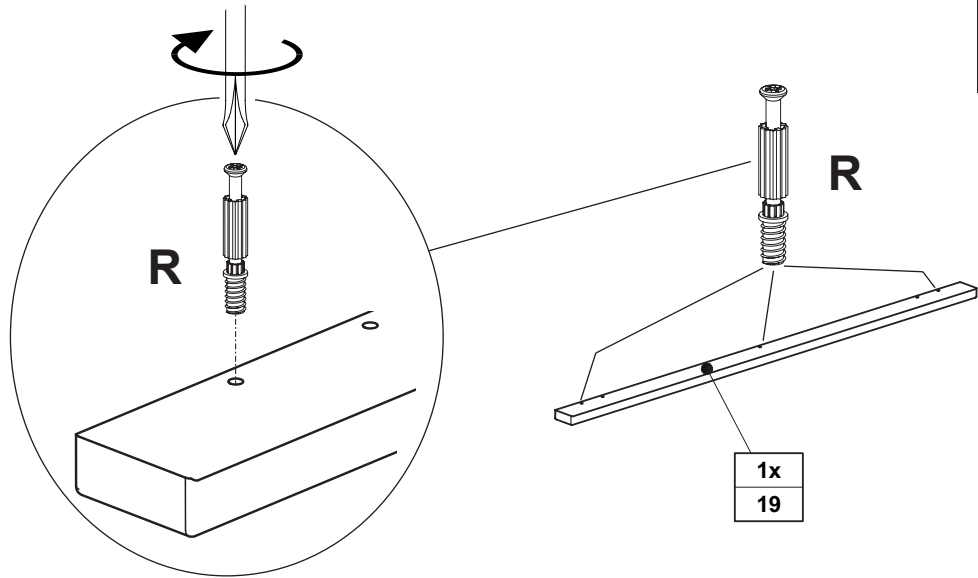

V8

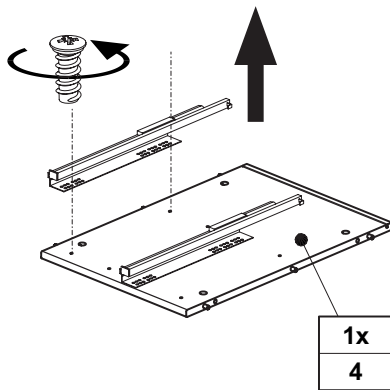

V7

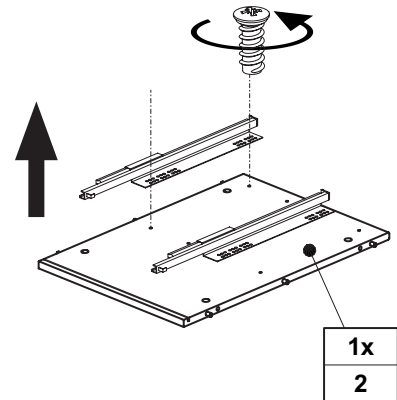

V9

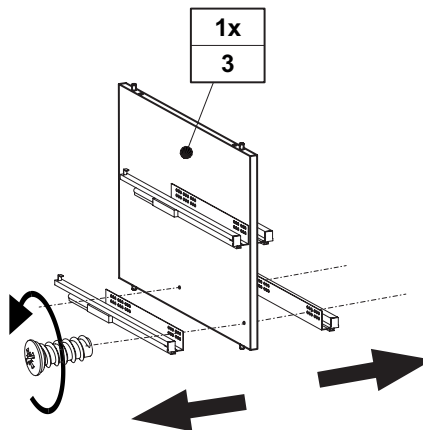

# V10

 = **Einbauhöhe der Einlegeböden ist variabel !**  
 The installation height of the connecting floor is variable!  
 La hauteur d'installation du fond de raccordement est variable !  
 ¡La altura de montaje del suelo de unión es variable!  
 Instalace výšky spojovacího dna je variabilní!

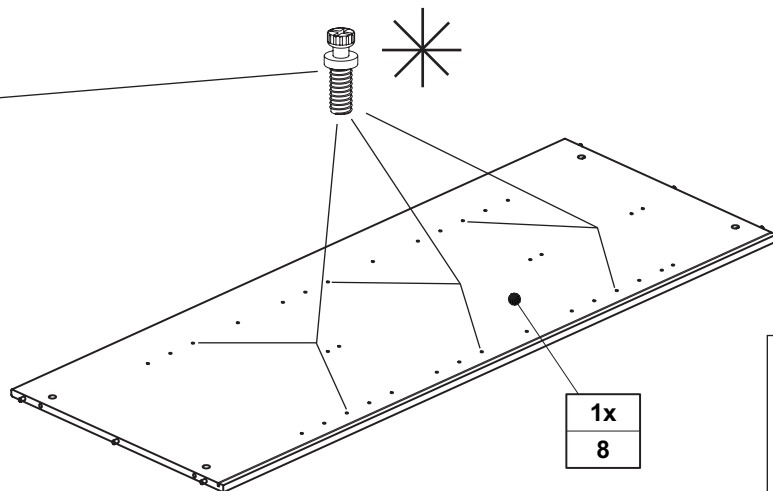
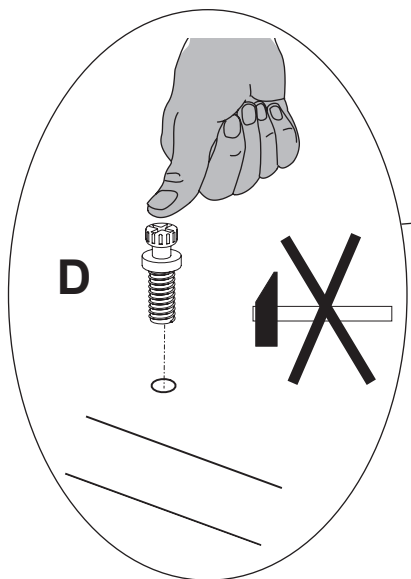

1x
8

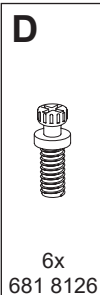

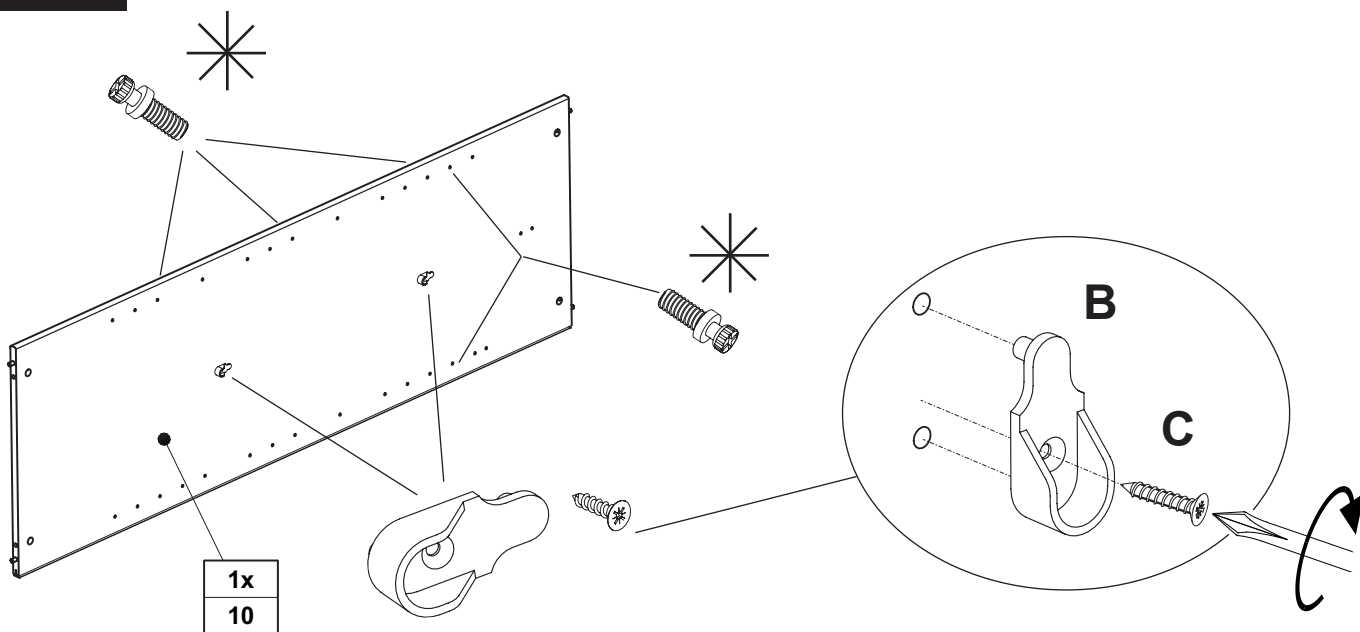

# V11

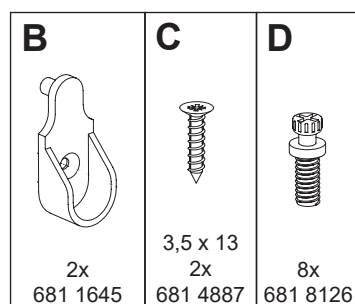

1x
10

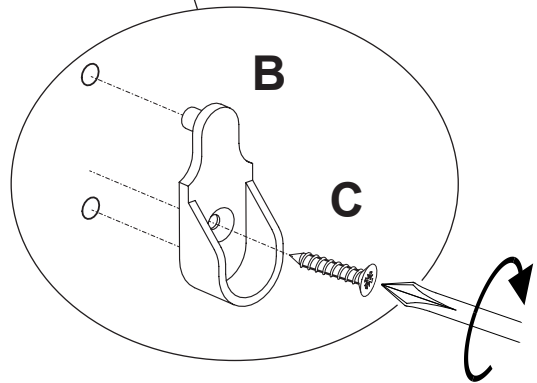
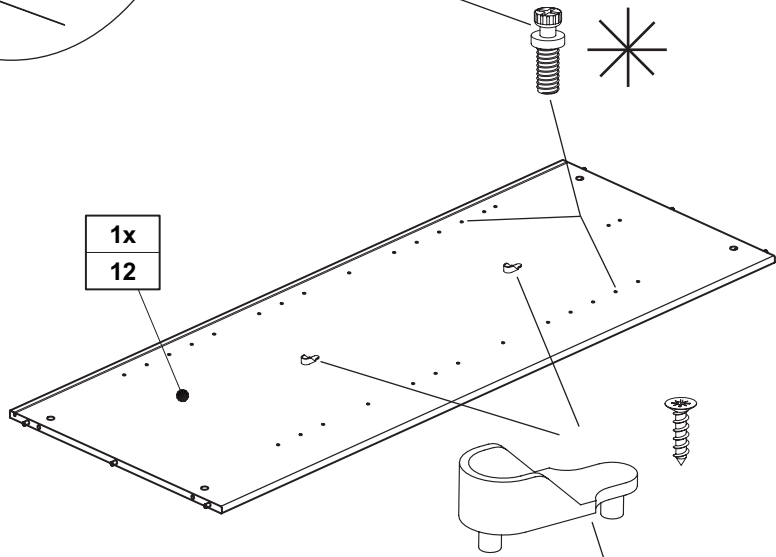
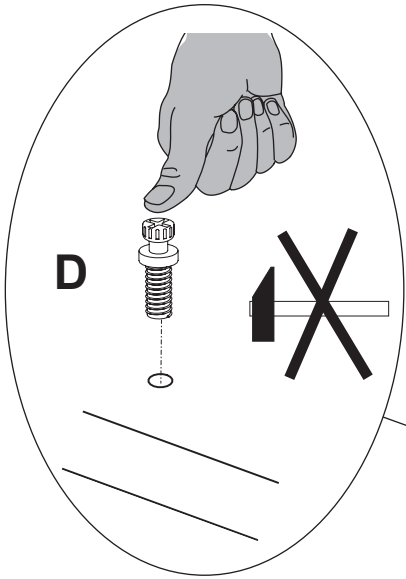

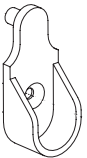

B	C	D
		
2x 681 1645	3,5 x 13 2x 681 4887	2x 681 8126

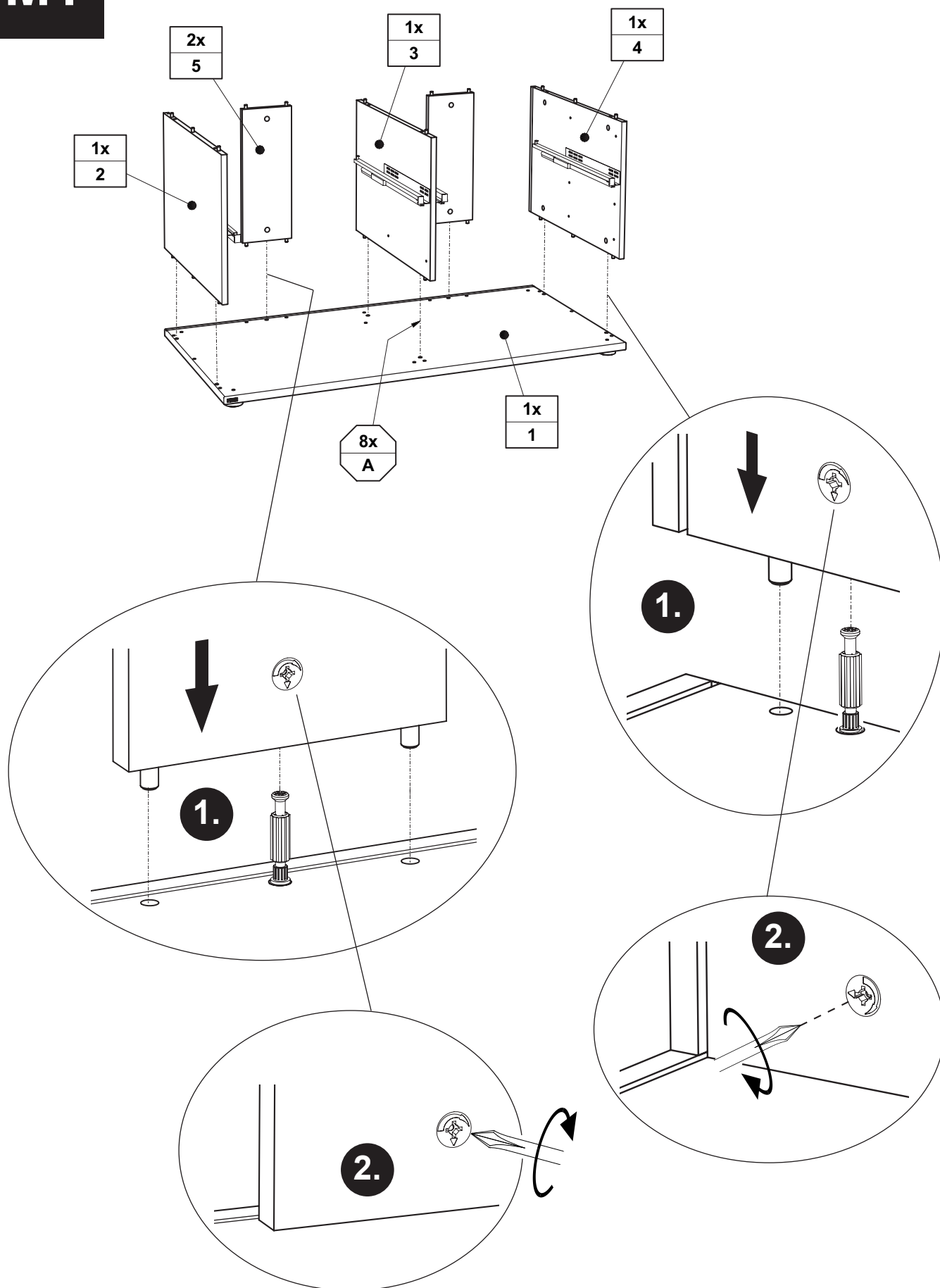

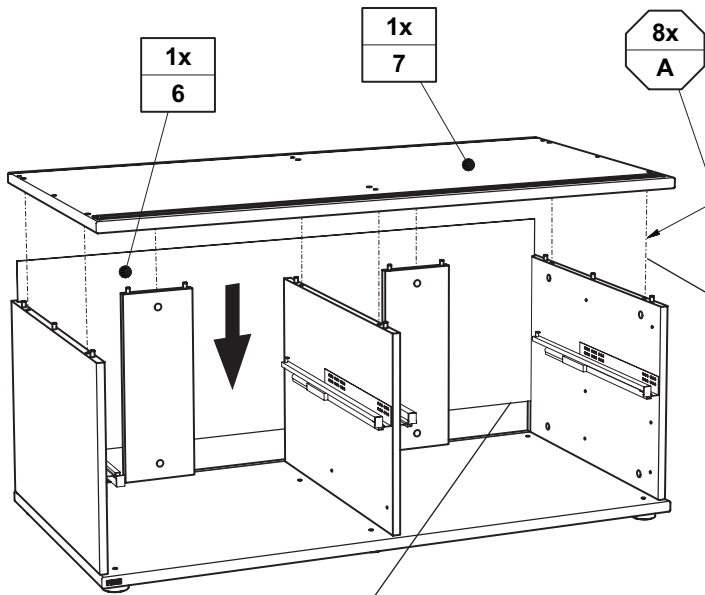

M2.1

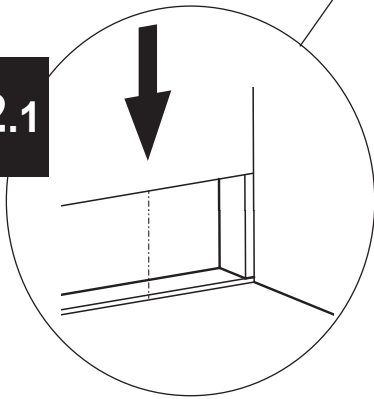

M2.2

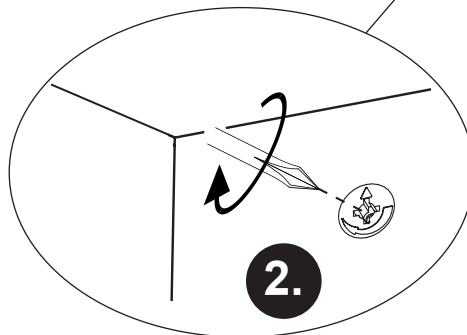
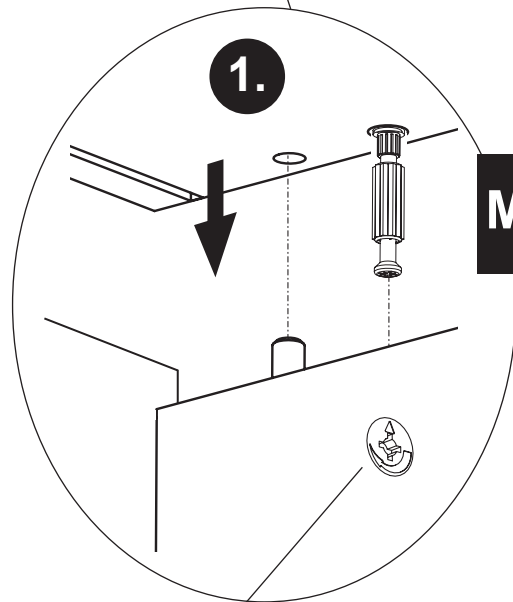

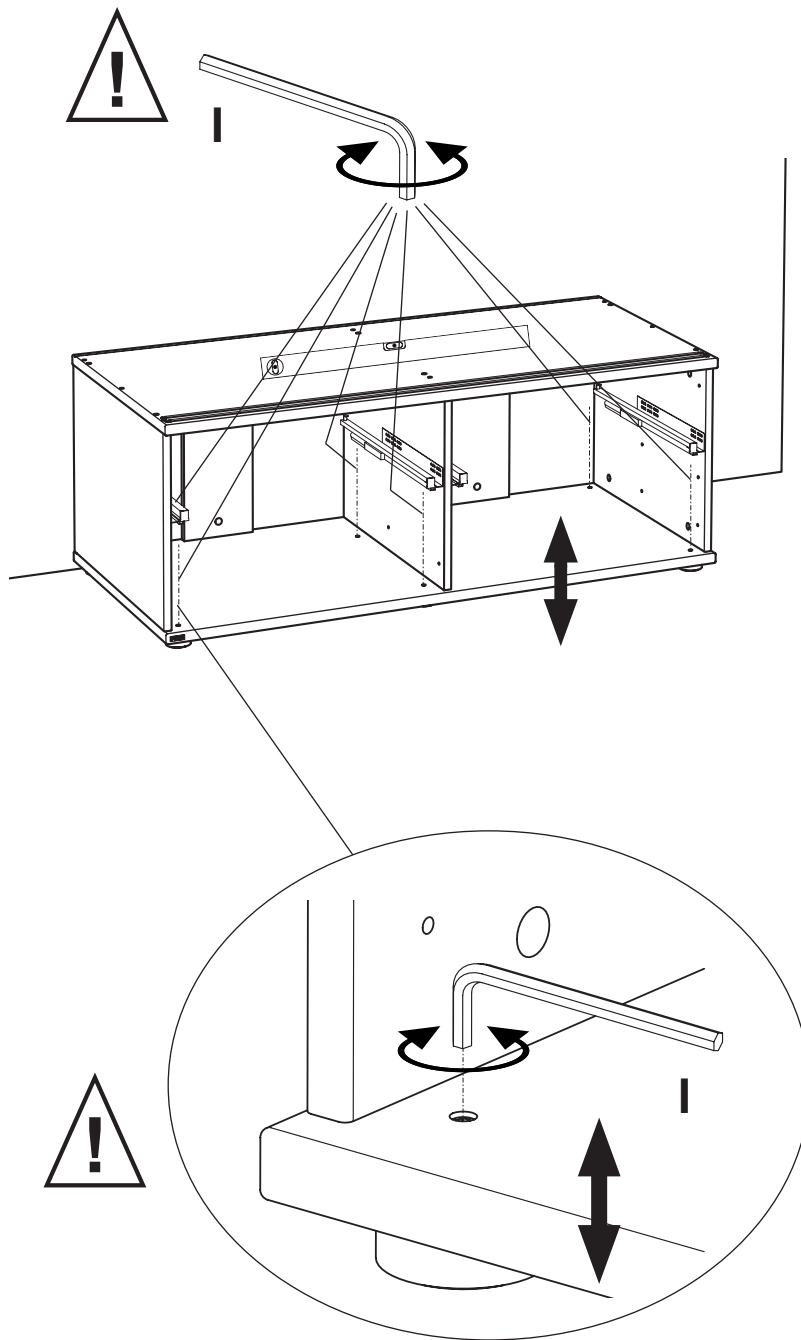

## Höhenverstellung !!

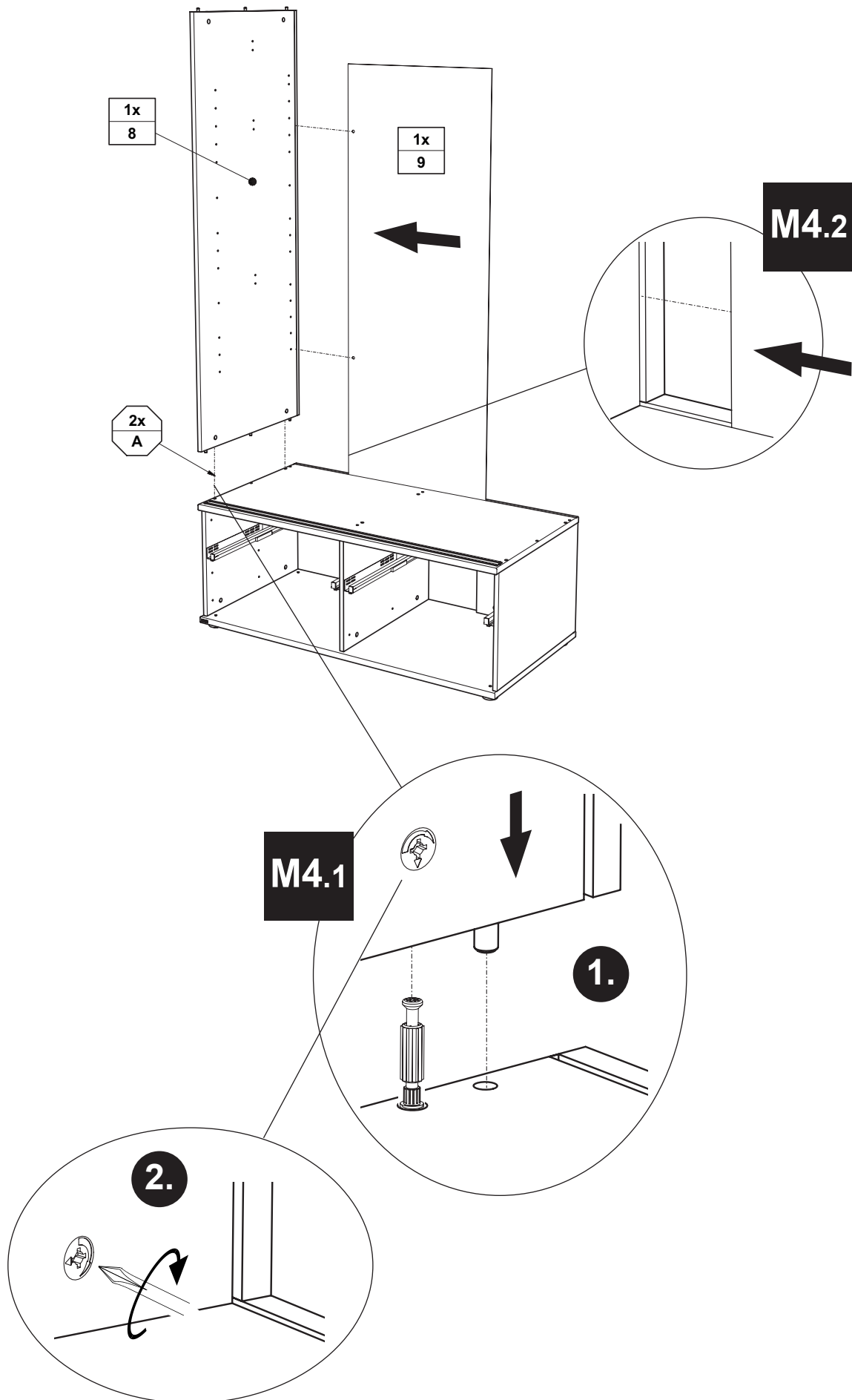

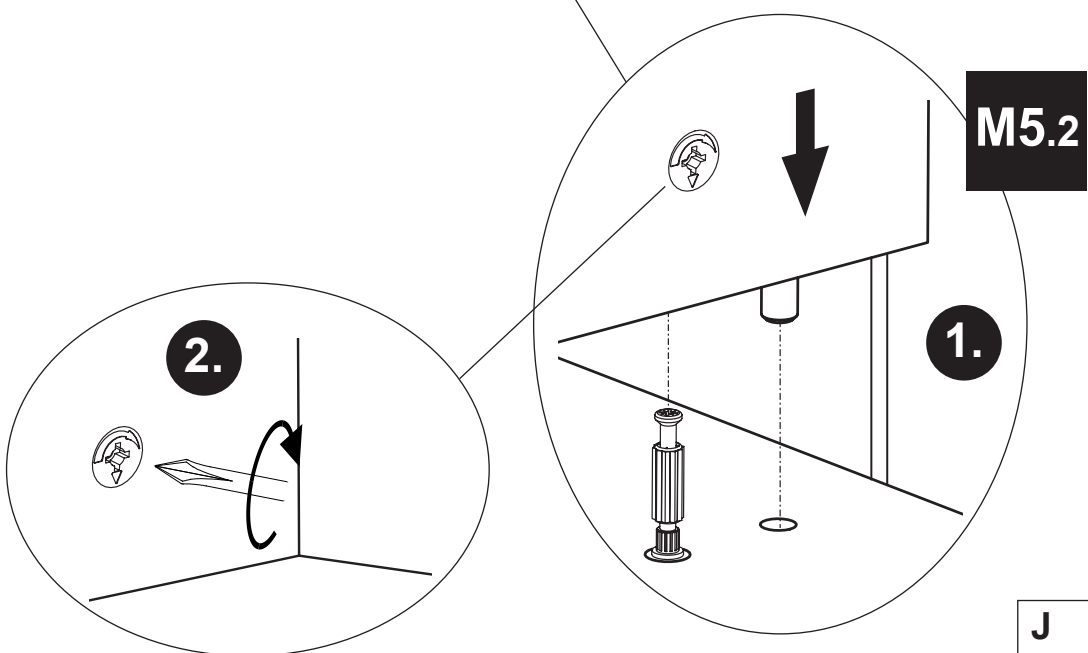
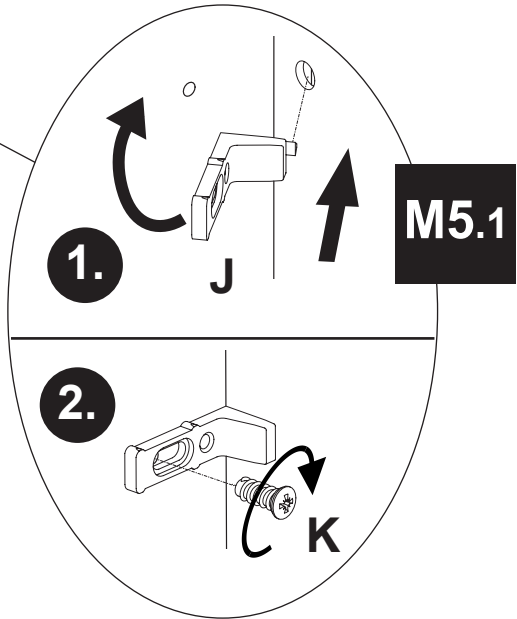
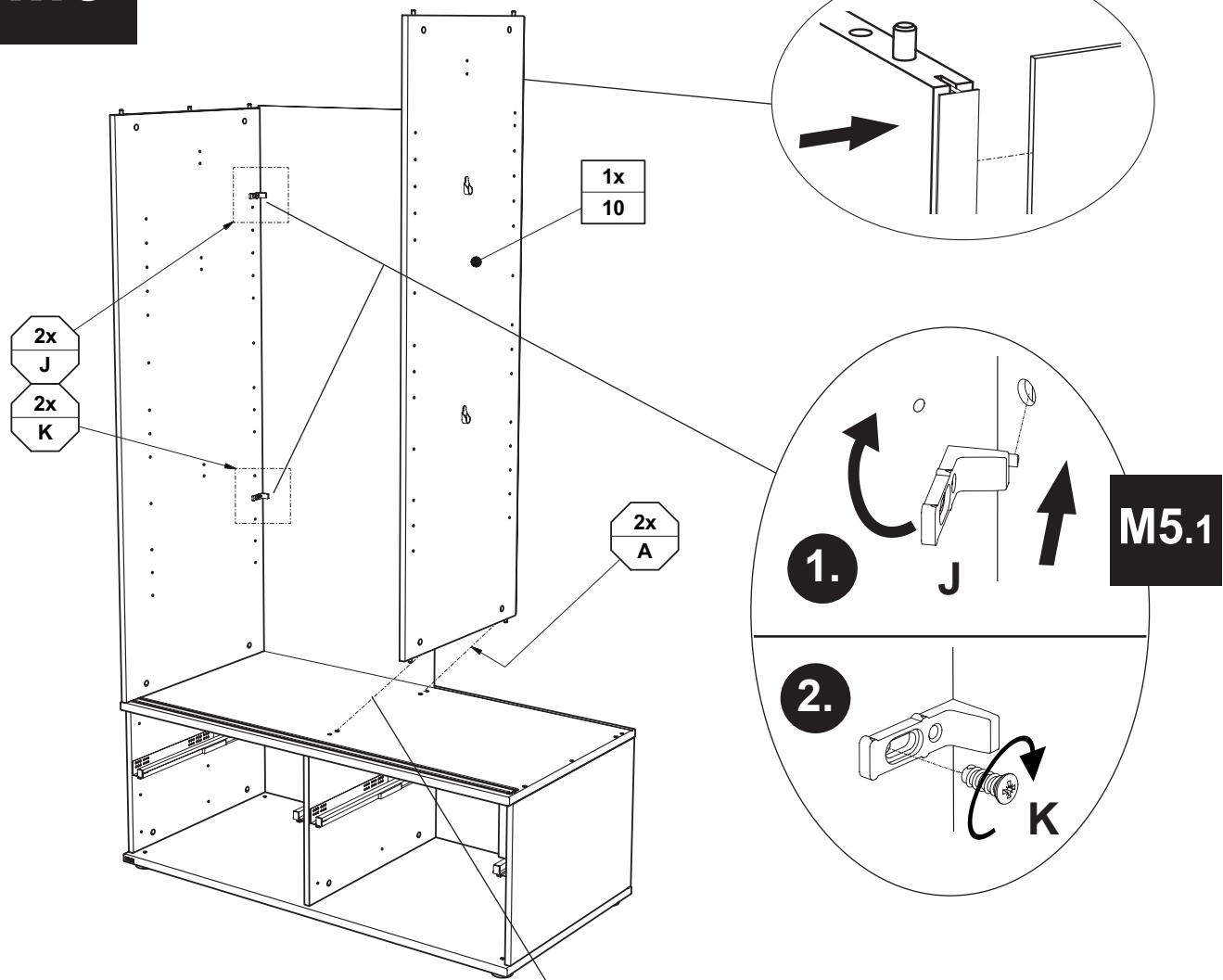

# M5

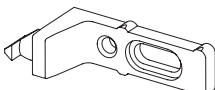

<p><b>J</b></p>  <p>2x 681 2497</p>	<p><b>K</b></p>  <p>6,3 x 15 2x 681 5060</p>
--	---



M6.1

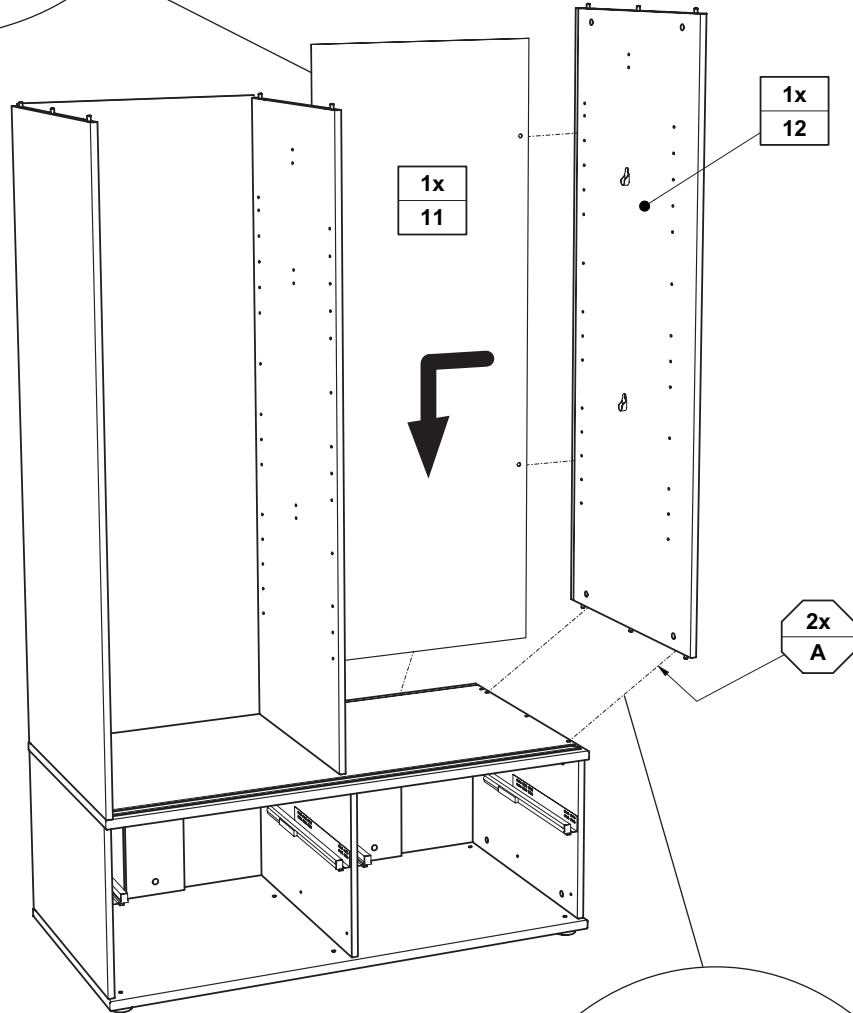
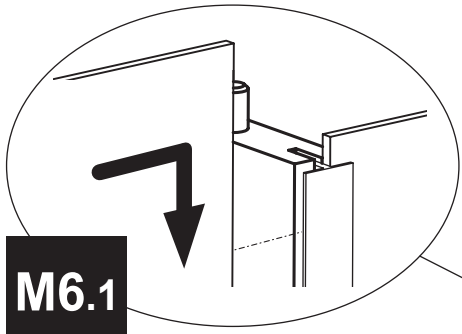

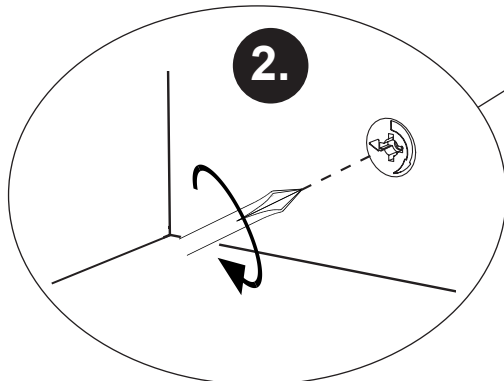
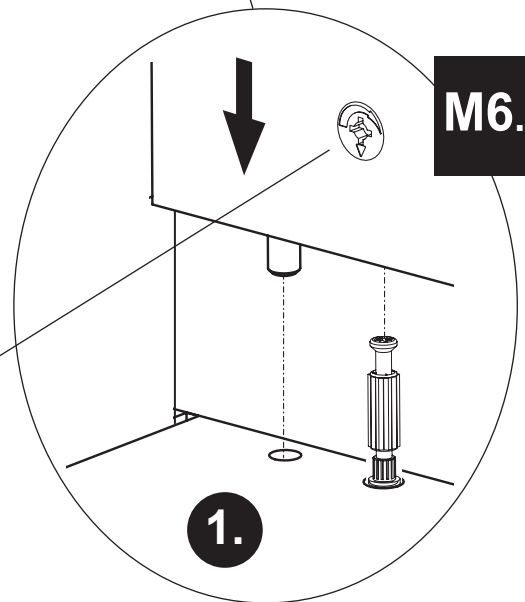

M6.2

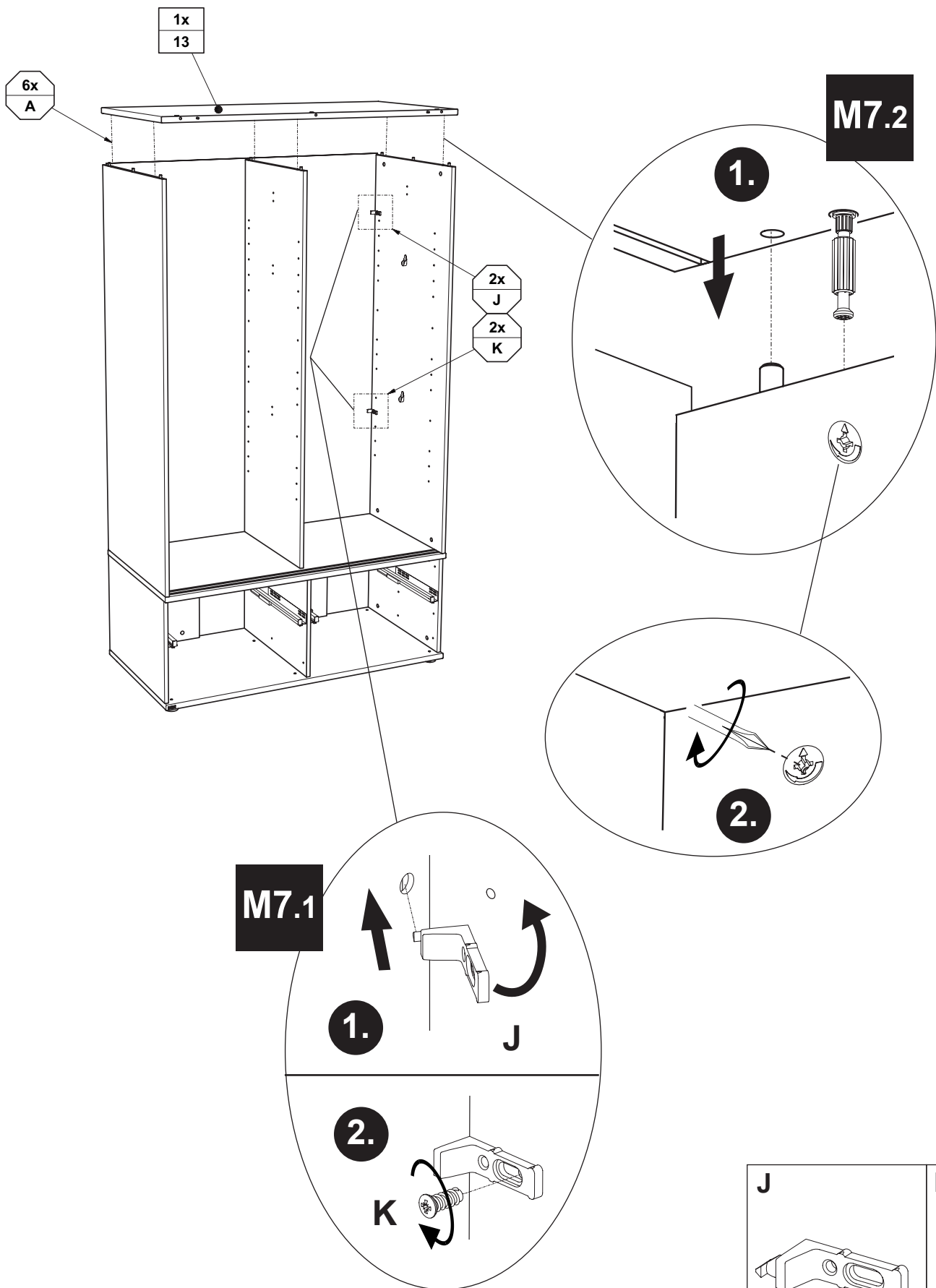

# M7

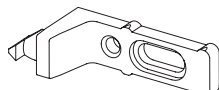

<b>J</b>	<b>K</b>
	
2x 681 2497	6,3 x 15 2x 681 5060

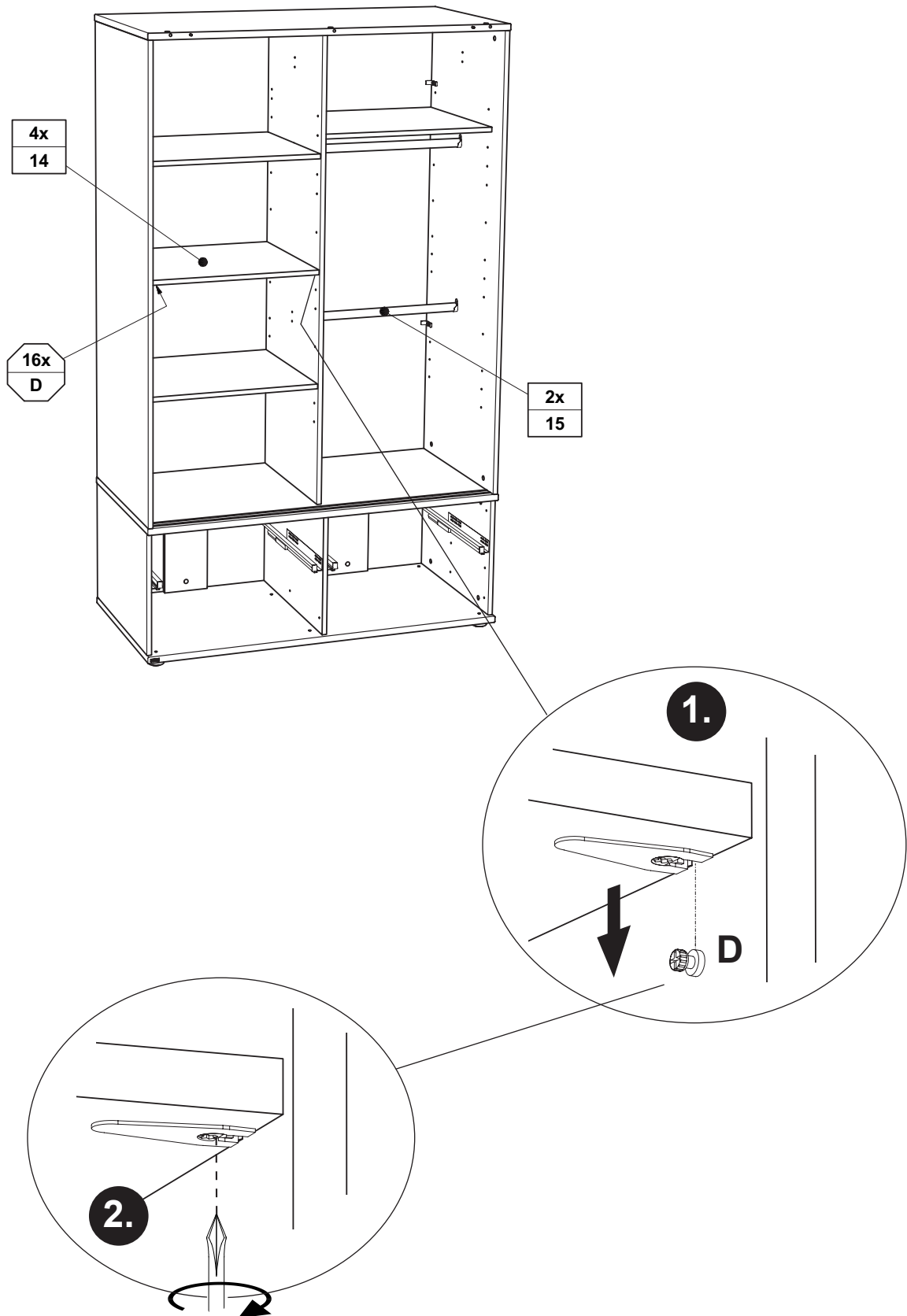

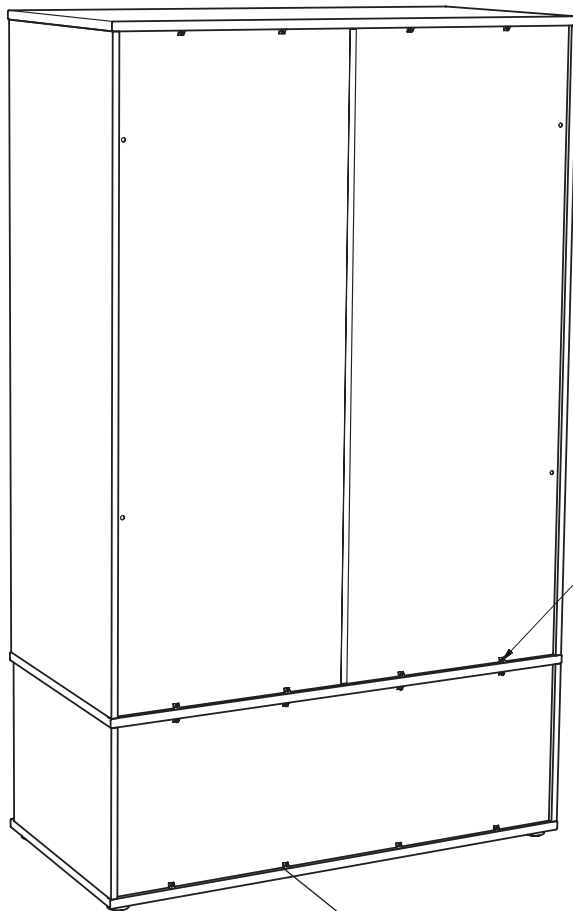

16x  
L

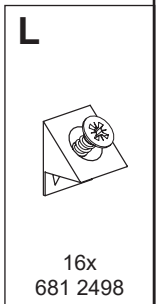
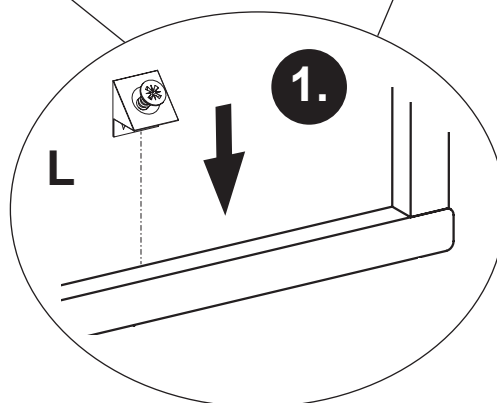
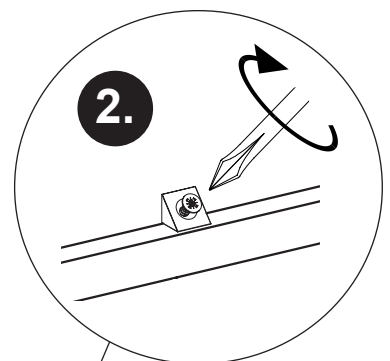

# Höhenverstellung !!

M10

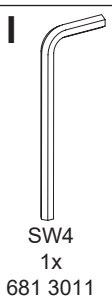
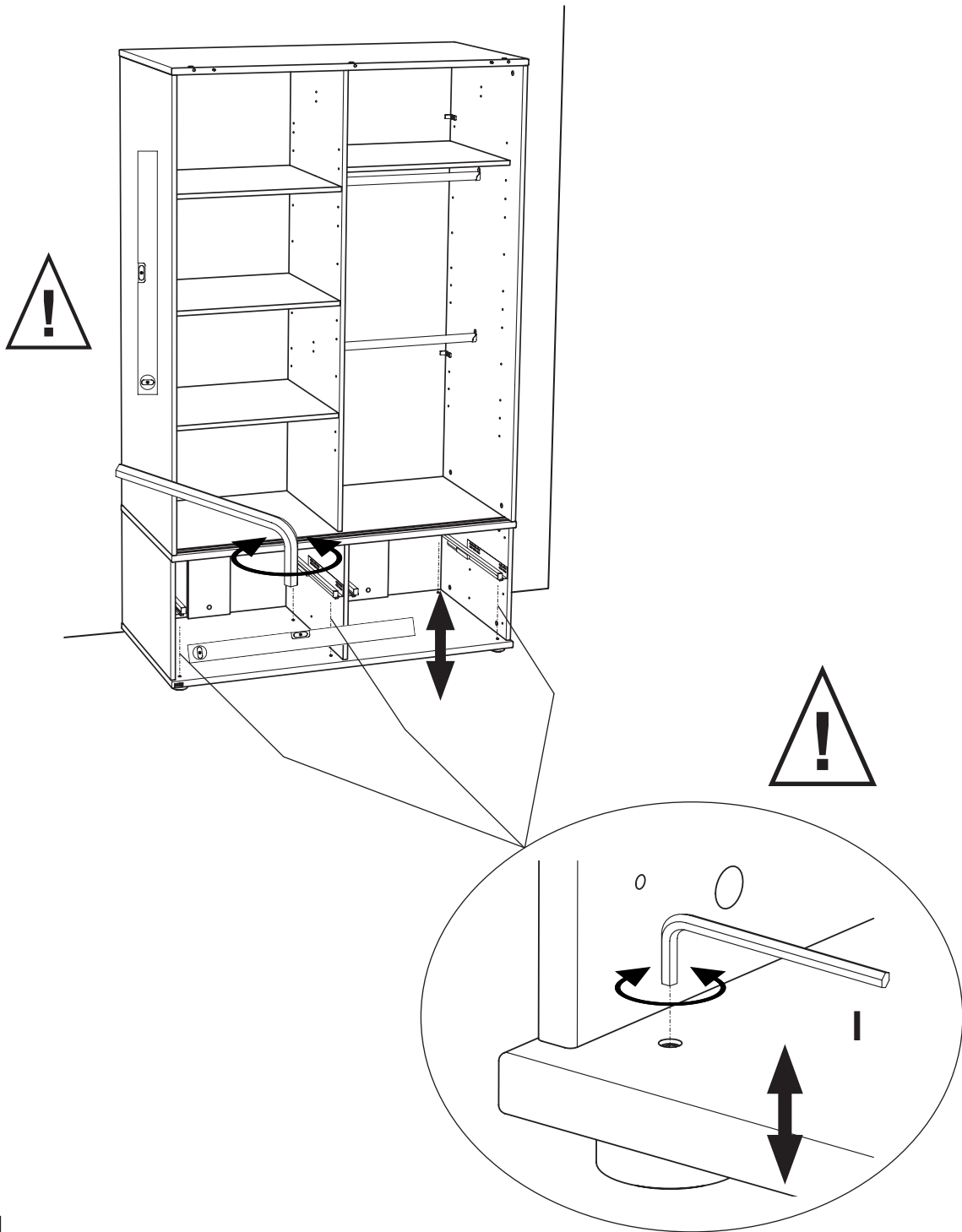

SW4  
1x  
681 3011

# M11

## Wandbefestigung !!

### ACHTUNG !!

Beiliegende Wandbefestigungsmaterial ist nur für massives Mauerwerk geeignet.  
Bei massiv abweichendem Mauerwerk müssen geeignete Befestigungsmaterialien verwendet werden.  
Prüfen Sie ob die notwendige Festigkeit gewährleistet ist.

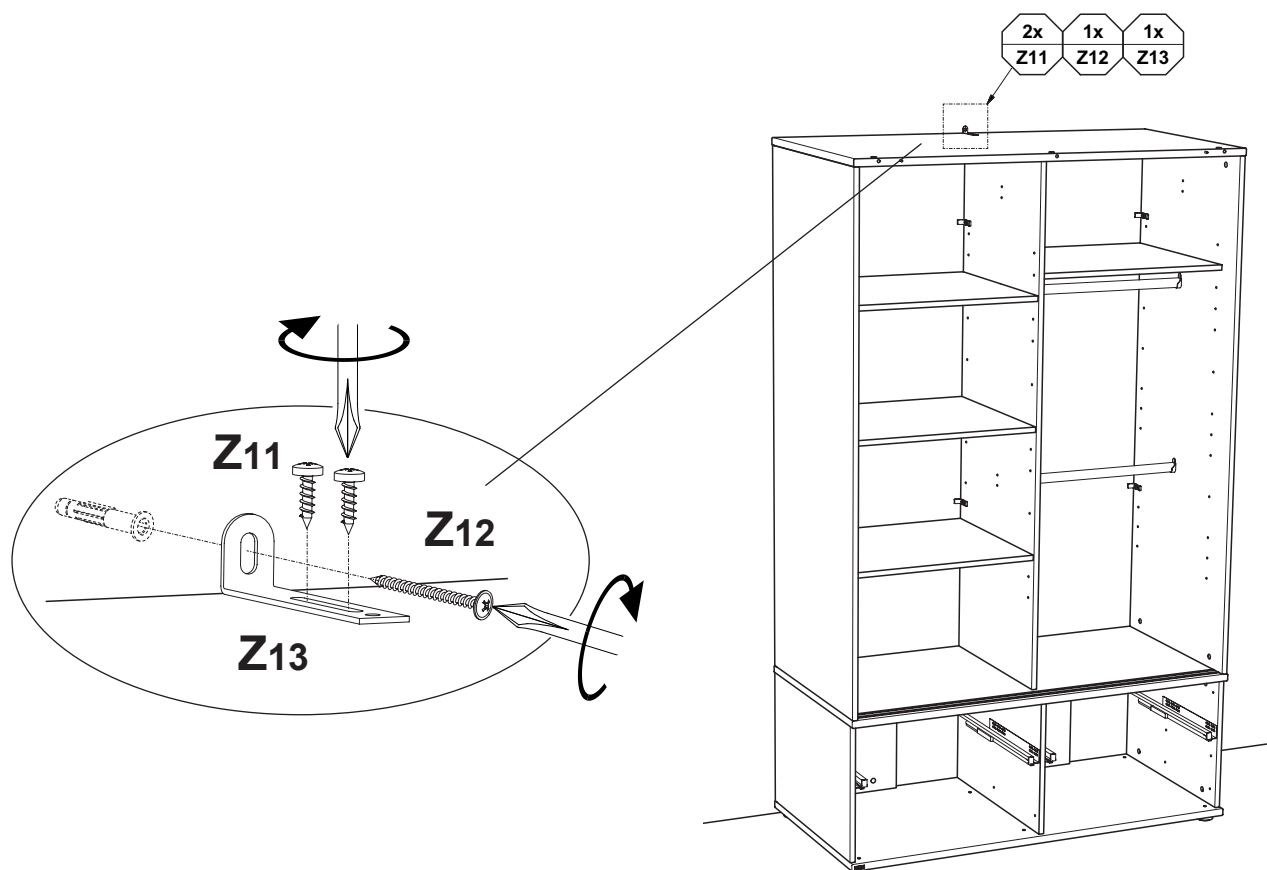



# M12

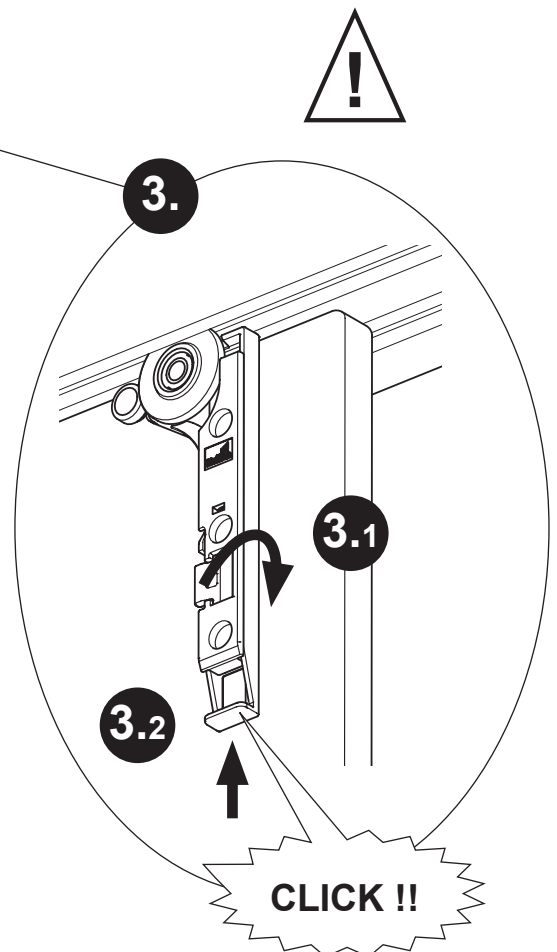
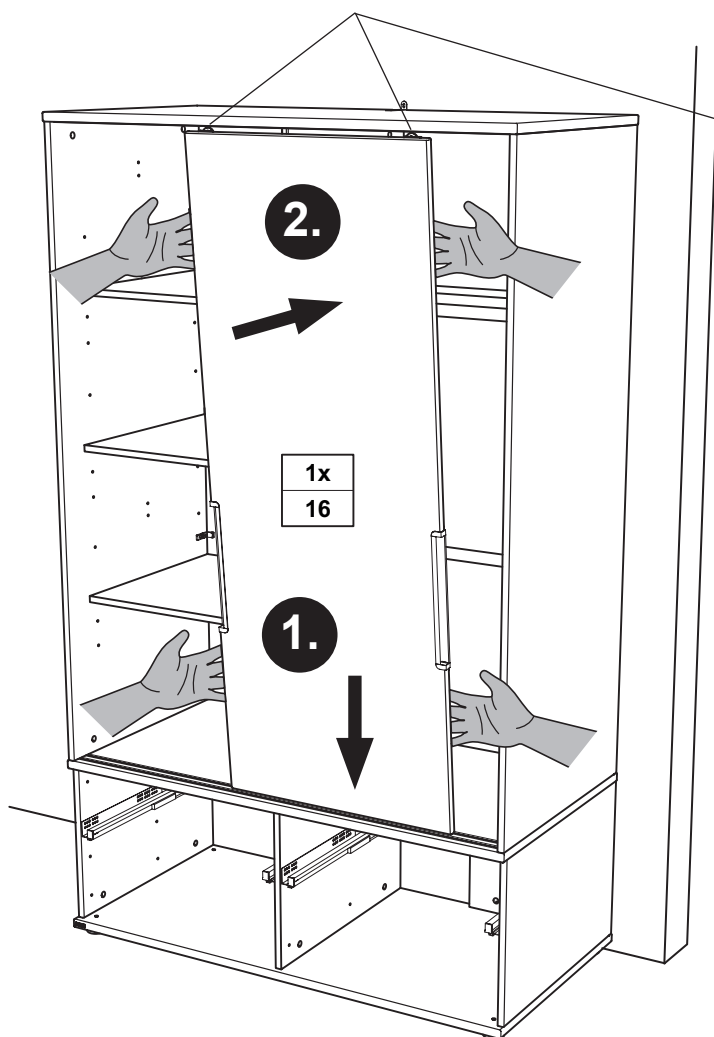
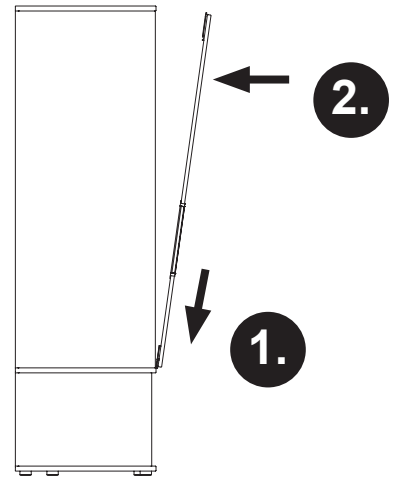
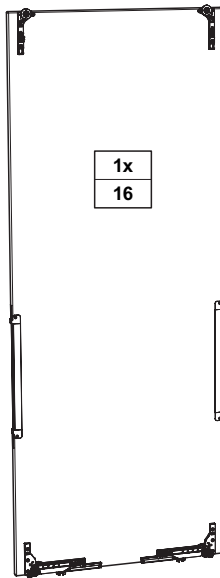
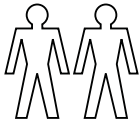



# Justierung der Schiebetür Hinten

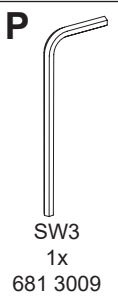
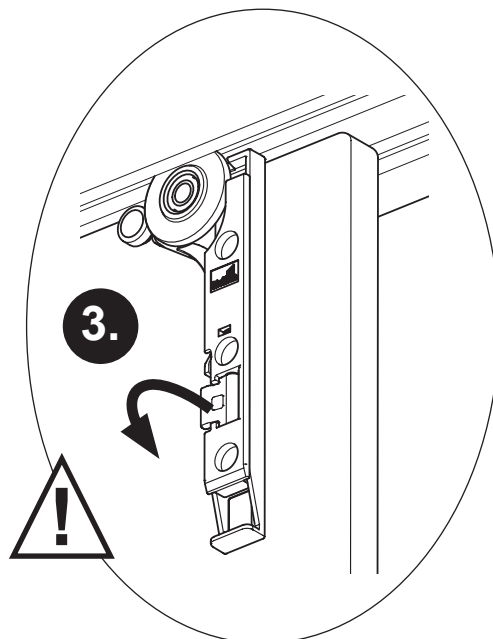
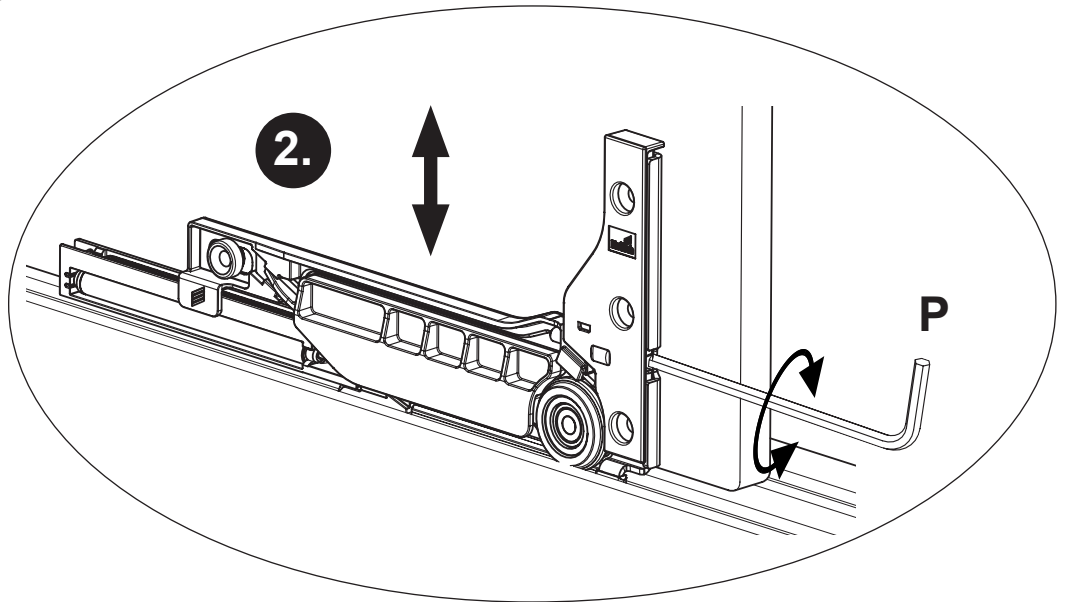
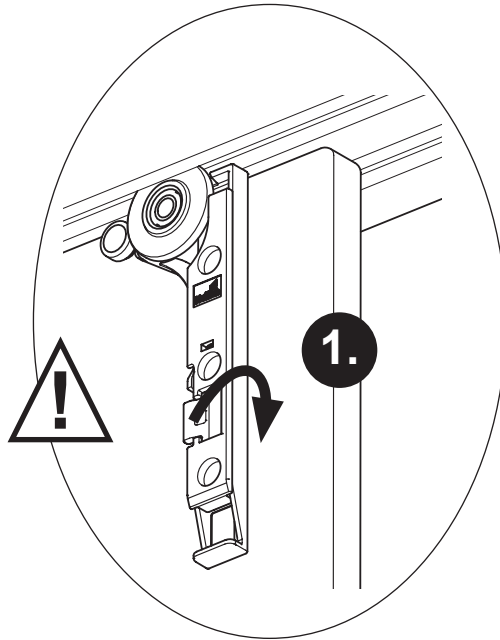
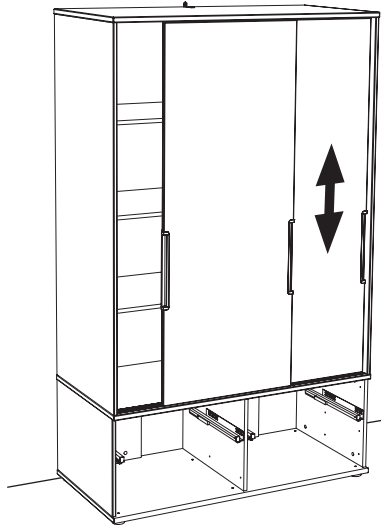

# M13

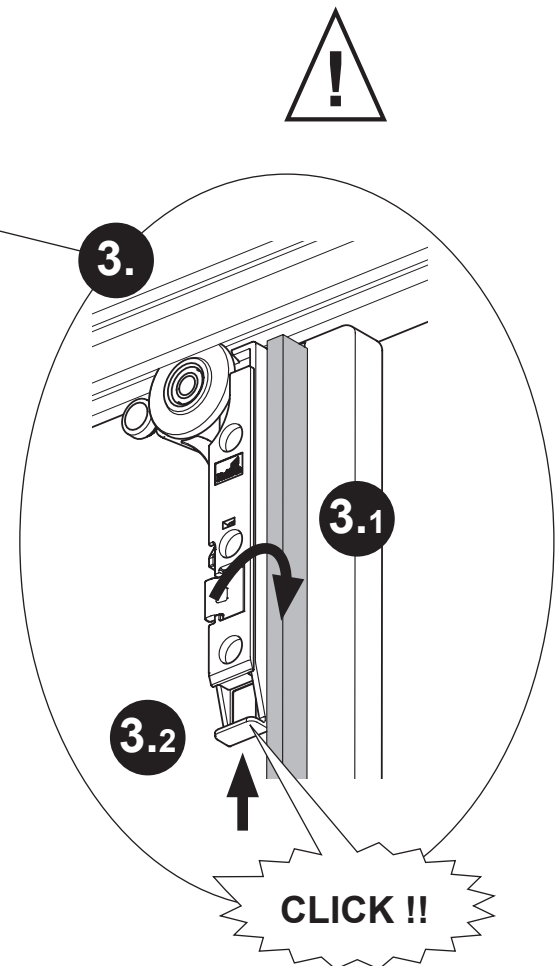
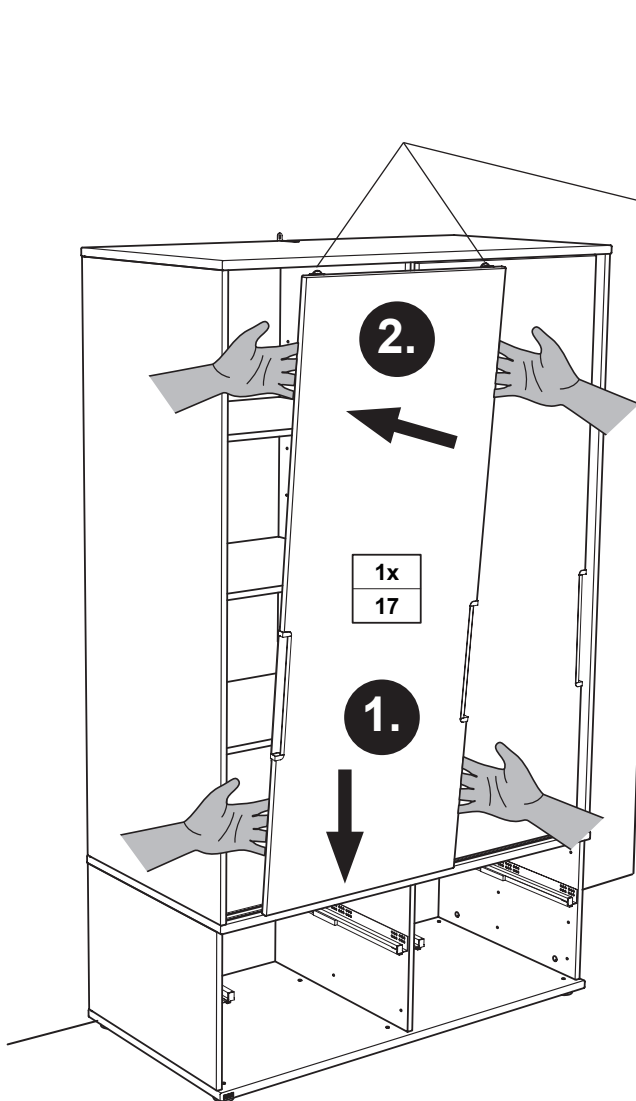
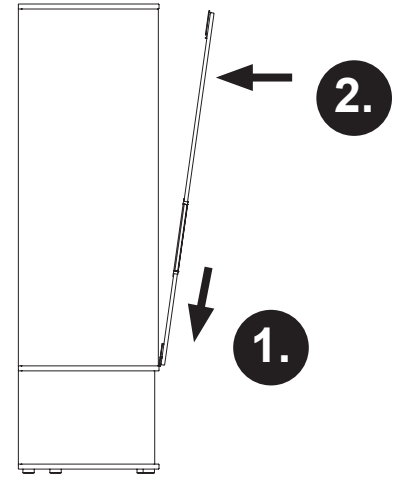
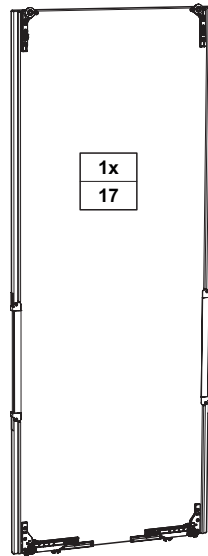
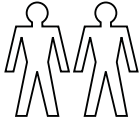

# Justierung der Schiebetür Vorne

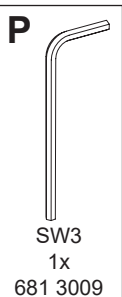
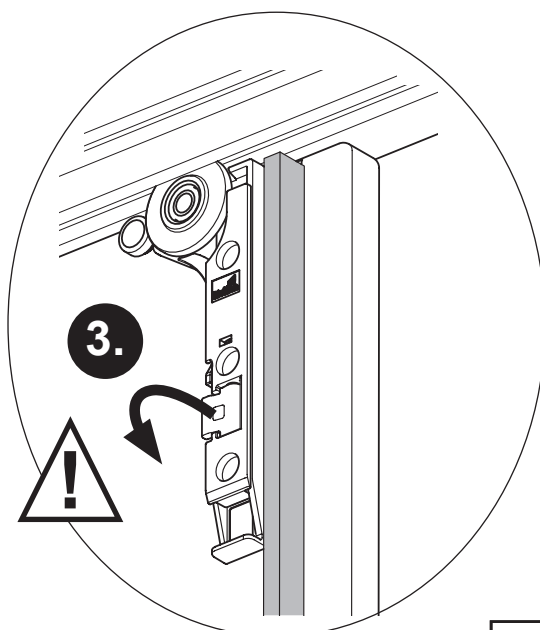
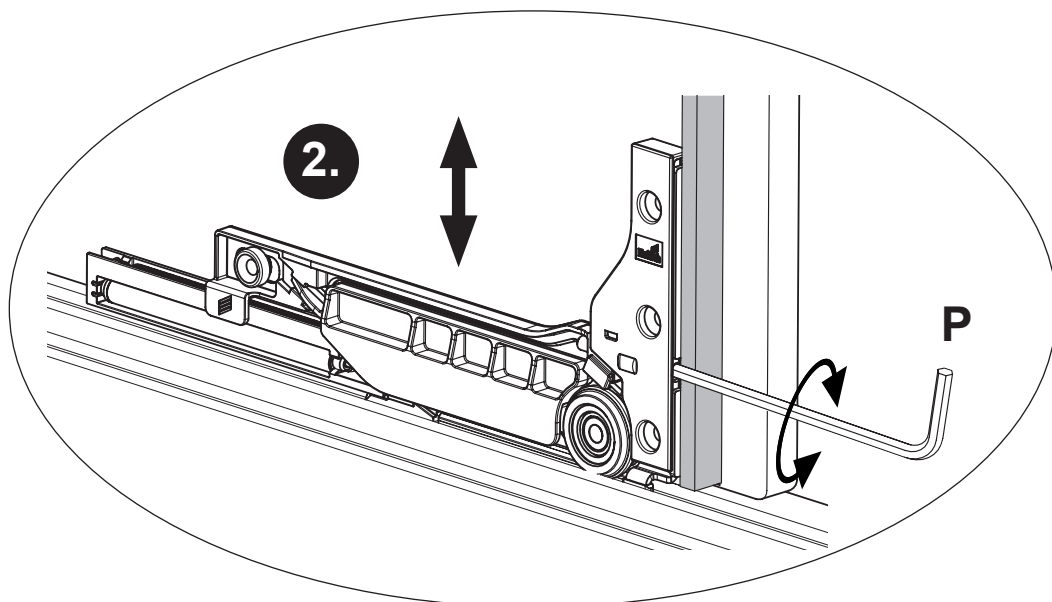
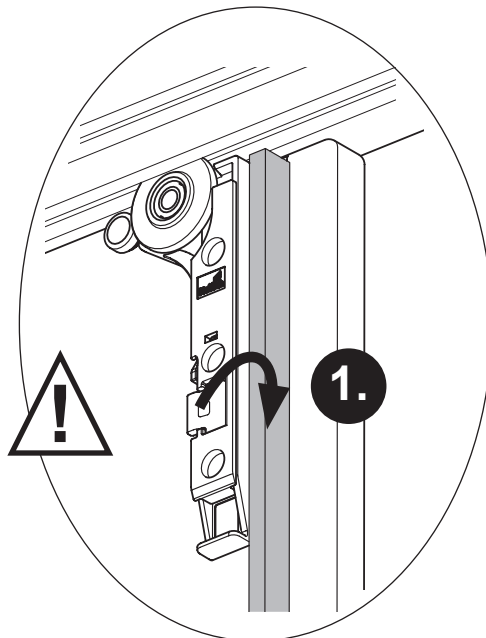
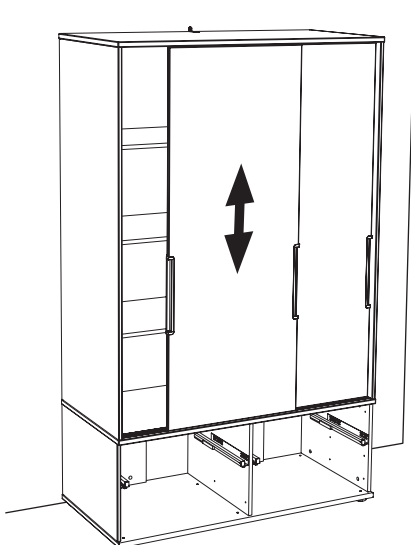

# M14

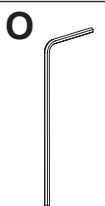
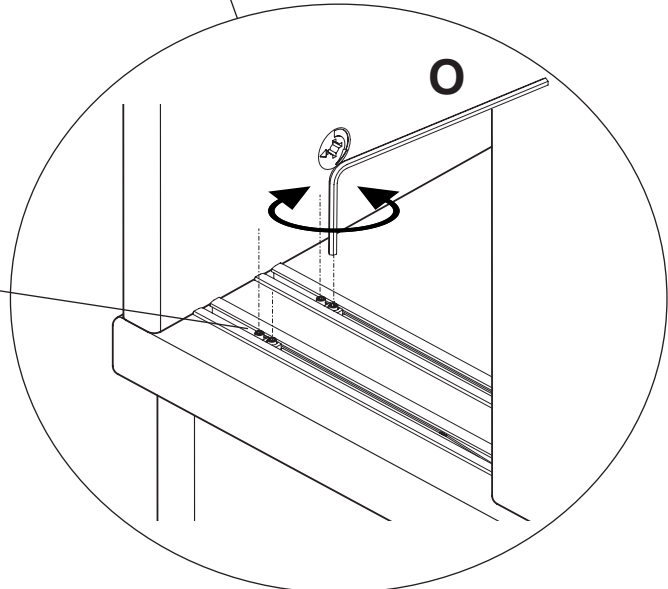
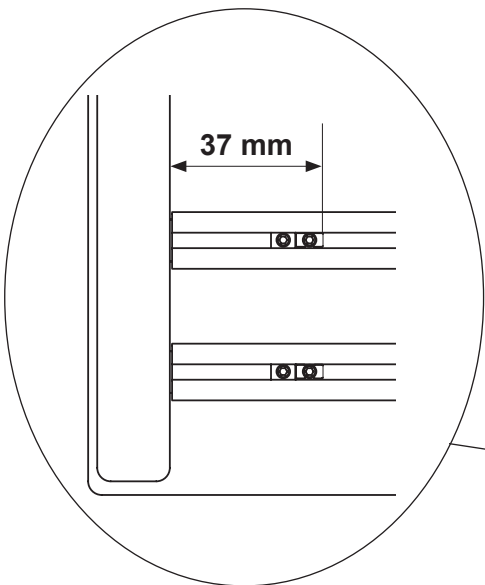
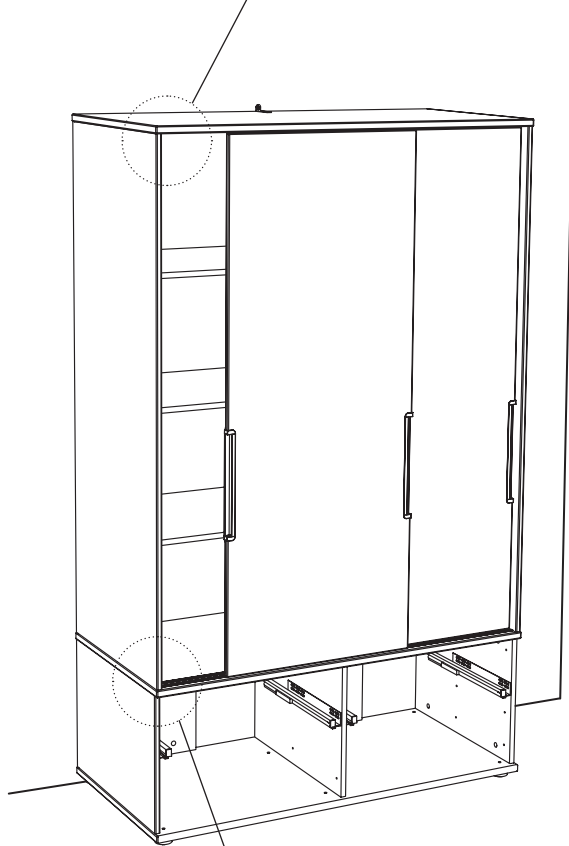
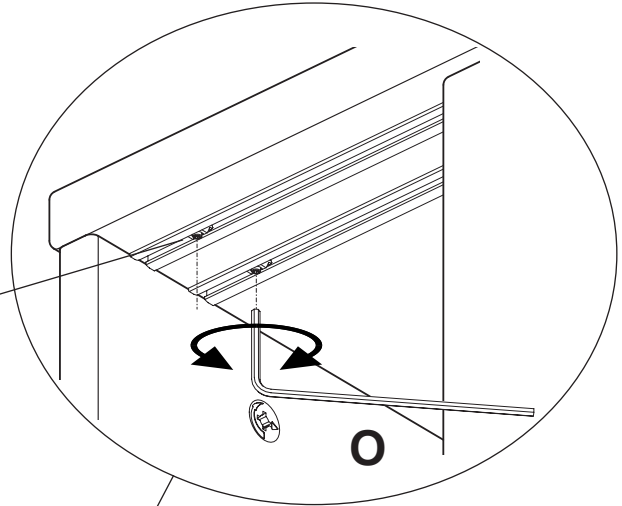
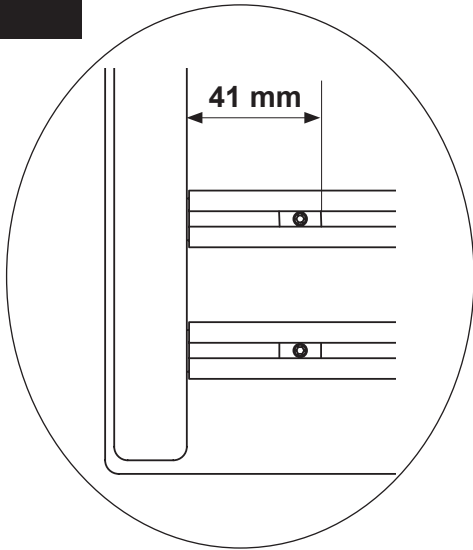

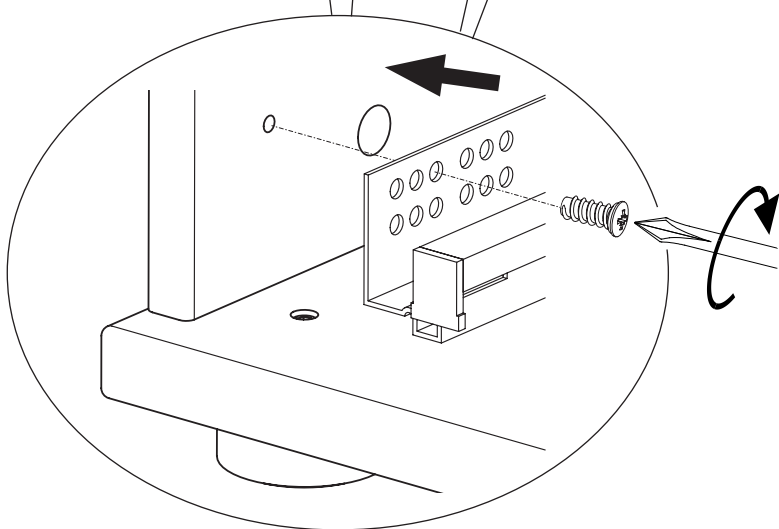
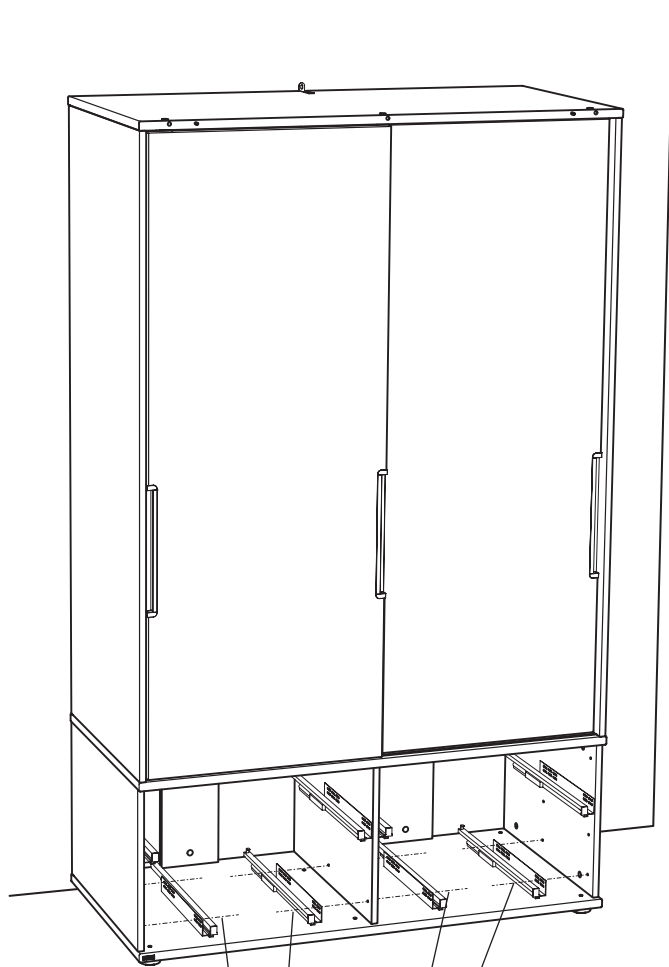

# M16

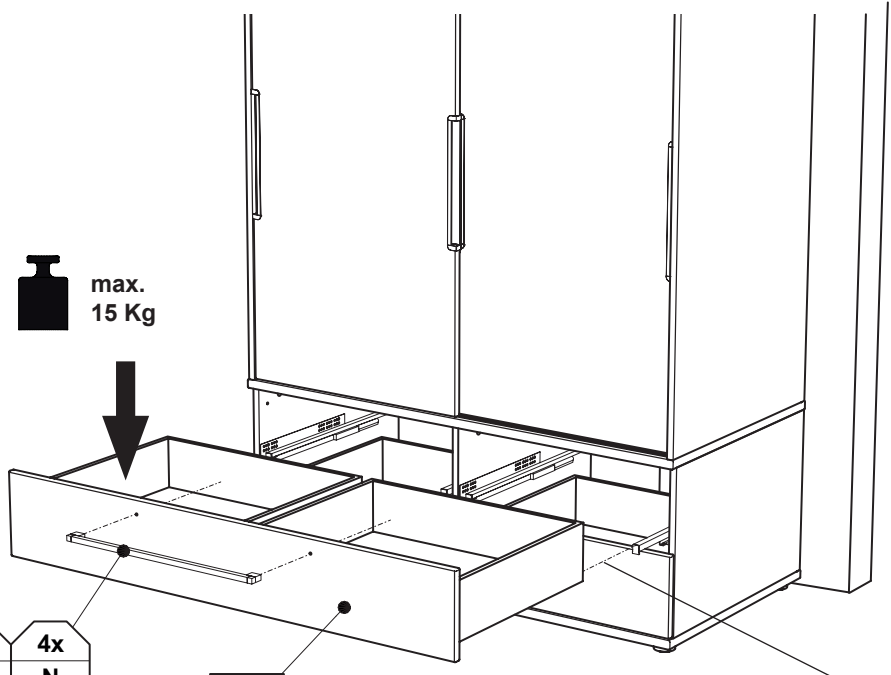

2x M  
4x N

2x 18

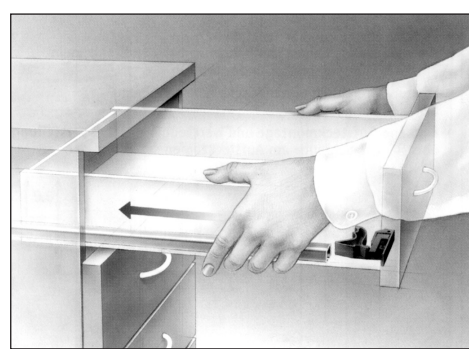
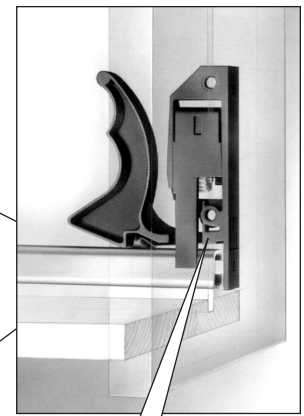

**CLICK !!**

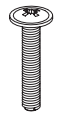
M	N
Griffstange	
2x 671 8408 / 681 8439	M4 x 22 4x (6x) 681 3807

## Justierung der Schubkästen

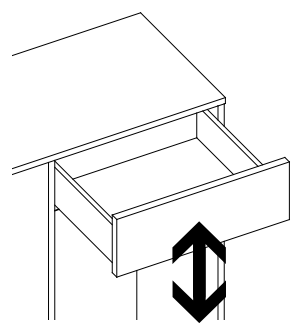
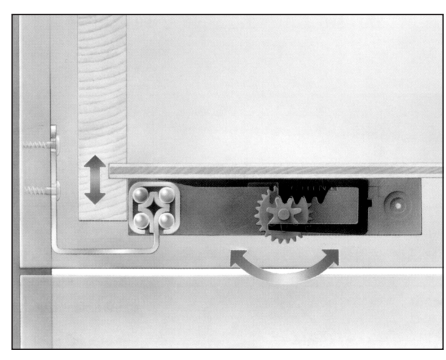
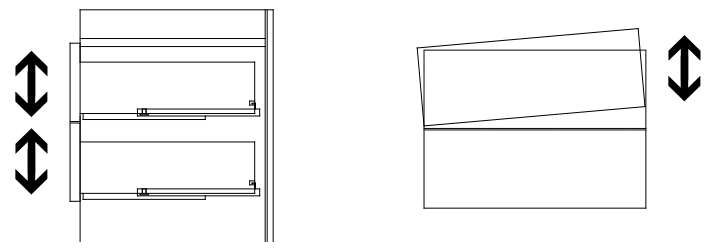

## Demontage der Schubkästen

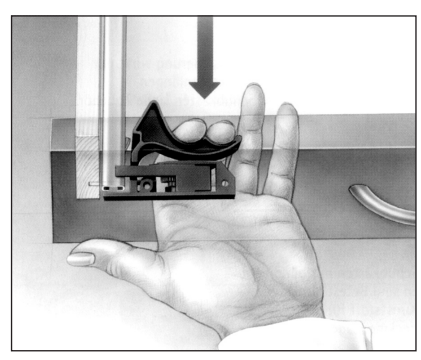

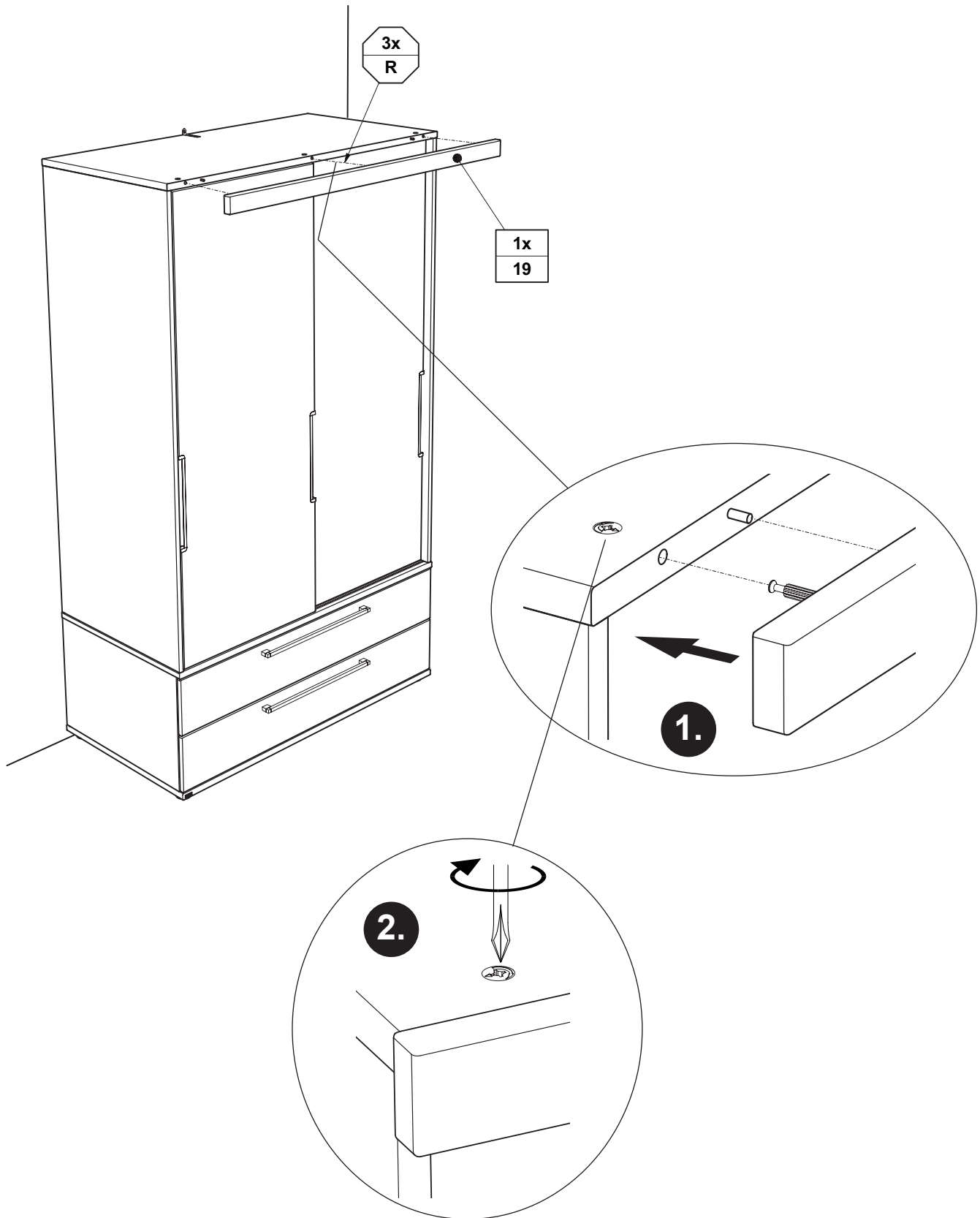

Bei defekten Beschlägen bitte  
**Code-Nr.** angeben.

