

LKZ 80236

Modellname / Model name / Nom du modèle / Modellnamn / Nome modello / Název modelu / Modelnaam / Ime modela / Numéro Modelo / Modell neve / Название модели / Názov modelu / Ime modela / Denumire model / Наименование на модела / Nazwa modelu

**SynnaX**

Modellnummer / Number / Numéro du modèle / Numero / Номер на модела / modello / Číslo modelu / Modell száma / Éíslo modelu / Številka modela / Număr model / Broj modela / Modelnummer / Numer modelu

**2134-911-84**

Type / Tipo / Tipus / Typ / Тип / Tip

**911**

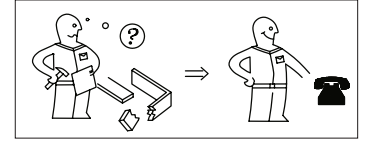
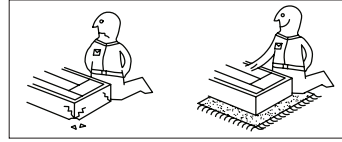
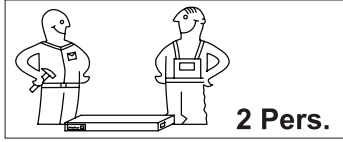

**2134-117-84**

 07-35

**2134-442-84**

 57-64

**2134-452-51**

 65-73

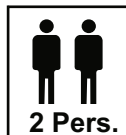
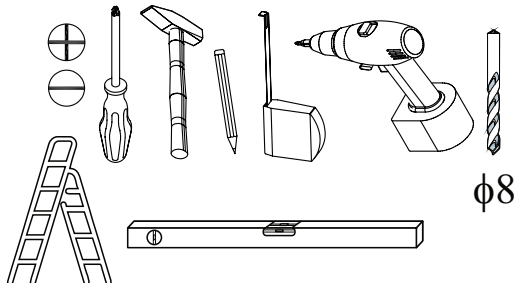
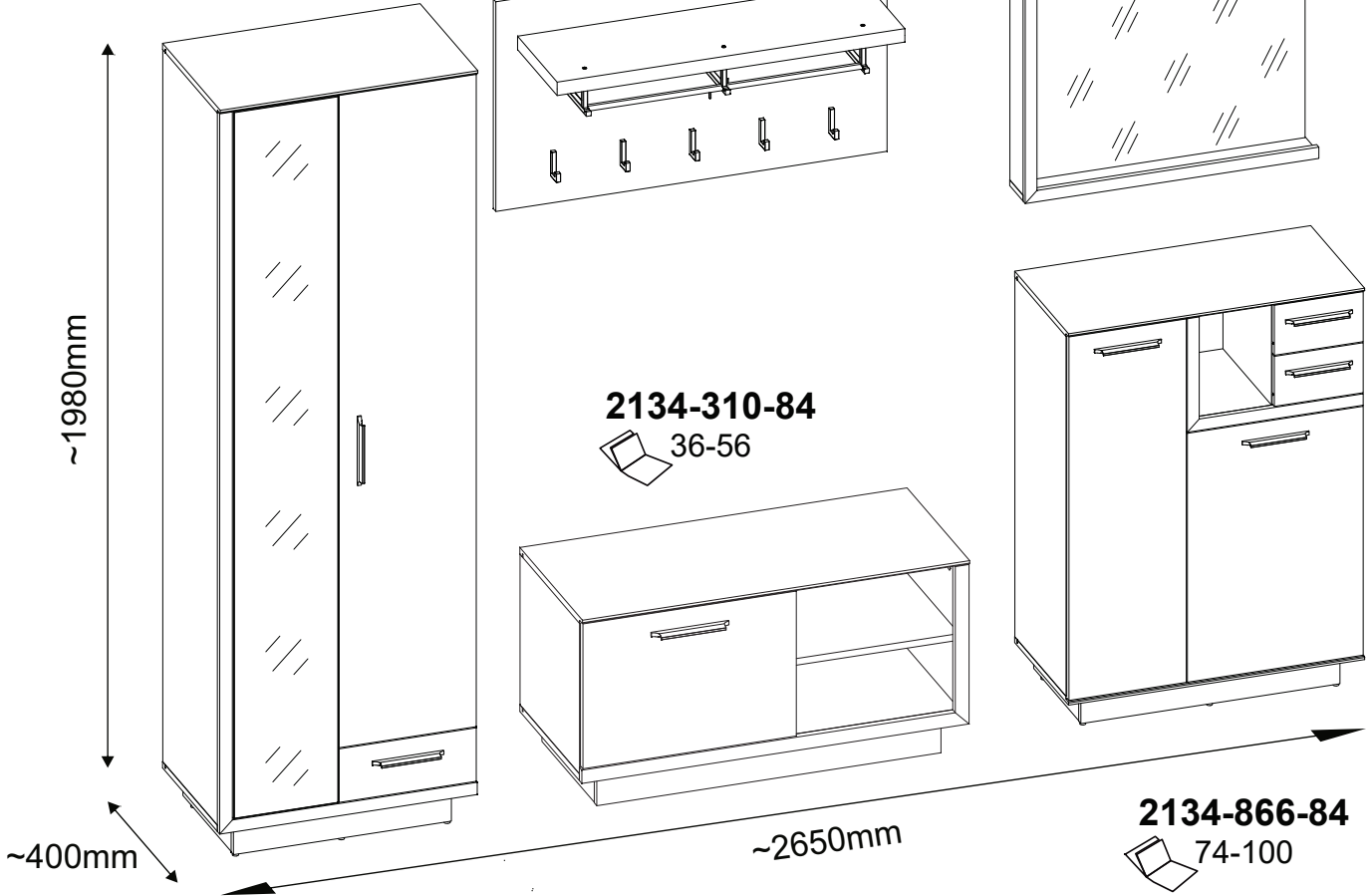

festziehen / tighten / Затягнете / serrer / stringere / utåhnut / vasttrekken / zategnuti / strångere / zwiázac / zacišnač / szorosan meghúzni / pevne dotiahnuť / trdno pritegniti / затянуть / dra át



eindrücken / press in / enfoncer / wcisnaç / ribattere / zatláčit / Вкарайте / indrukken / benyomni / stlácit / vtisniti / tryck in / introducere prin apăsare / вдвигать



ausmessen / measure / mesurer / misurare / opmeten / izmeriti / miara / kimérni / izmeriti / măsurare / измерить / změřit / Измерете / mät upp / zmierzyc



drücken / press / presser / stisknout / Натиснете / vtisniti / nasinac / drukken / pritisnuti / nacisnac / pritisniti / нажать / (meg)nyomni / apasare / tryck fast / nacisnaç



einschlagen / hammer in / bevèrni / sla in / frapper au marteau / infossare / Zabit' / zarazit / Набийте / zabiti / wbić / introducere prin bătaie / забить / zatloout



Drehen - wenden / przekreçić - odwróciç / Keren - omdraaien / Girare - Ruotare / Okrenuti - ubrnuti / Retourner - renverser / Turn over - turn around / Otoçte - obratle / Завъртете - обърнете / Obrnite list / Întoarçeti - rotii / Vrid runt - vänd / прокрутить - повернуть / otoçit - obrátit / elforgatni - megfordítani

DE	BG	CS	EN
<p>Sehr geehrte Kundin, sehr geehrter Kunde, wir danken Ihnen für den Kauf eines Möbels aus unserem Innenraum-Programm zum ausschließlichen Gebrauch in privaten Räumlichkeiten. Bitte prüfen Sie den Lieferumfang auf Vollständigkeit und lesen Sie sich nachstehende wichtige Informationen vor der Montage sorgfältig durch und bewahren Sie diese für spätere An-/Verwendungen, auch durch Dritte, auf.</p> <p>Unsere Möbelstücke sind bestimmungsgemäß einzusetzen. Die nicht bestimmungsgemäße Verwendung kann zu Sachschäden oder unter Umständen zu Personenschäden führen. Möbel sind keine Kinderspielzeuge. Für Schäden, die durch nicht bestimmungsgemäßen Einsatz oder durch falsche Handhabung entstehen, übernimmt der Hersteller oder Händler keine Haftung.</p> <p>A C H T U N G: Kinder oder Personen mit geistiger Behinderung sind stets von Möbelteilen, spitzen Gegenständen, Kleinteilen und Verpackungsmaterialien fernzuhalten, es besteht Verletzungs- und/oder Erstickungsgefahr.</p> <p>M O N T A G E: Bitte richten Sie sich bei der Montage nach unseren Betriebs-, Bedienungs-, Installations- oder Montageanleitungen und achten Sie insbesondere auf Warn- und Sicherheitshinweise. Werden Anweisungen nicht befolgt, kann dies zu Verletzungen bei Personen oder zu Schäden am Möbel führen / zu einem Sicherheitsrisiko werden. Sollten Sie Schwierigkeiten beim Aufbau / bei der Montage haben, kontaktieren Sie bitte unser Serviceteam. Dieses steht Ihnen mit Rat und Tat zur Seite. Die Montage darf nur durch fachkundige Personen durchgeführt werden. Bei Änderungen am Produkt/Produktteilen, beim Austausch bzw. Einsatz von Teilen / Verbrauchsmaterialien, die nicht vom Hersteller/Händler stammen, kann keine Haftung für Schäden übernommen werden.</p> <p>Wenn der Ware Wandbefestigungsmittel wie Dübel und Schrauben beiliegen, sind diese ausschließlich zur Anwendung an Wänden aus massiven und einheitlichen Materialien bestimmt. Eine Befestigung ist nur so gut wie die Verbindung zwischen Befestigungsmittel und Wand. Bitte prüfen Sie sowohl bei stehenden als auch bei hängenden Möbelstücken vor deren Befestigung Ihre Wand auf ihre diesbezügliche Eignung und verwenden Sie nur dafür geeignete Befestigungsmittel. Vor eventuellen Bohrarbeiten vergewissern Sie sich, dass keine Leitungen im Bohrbereich liegen. Letztendlich ist der Monteur für die Befestigung an der Wand verantwortlich.</p> <p>Dies betrifft auch die Installation von Elektroartikeln sowie anderen bautechnischen Zubehörteilen. Die Montage / Installation von Elektroartikeln sowie anderem baurelevanten Zubehör sind nur von autorisierten Fachpersonal durchzuführen. Alle elektrischen sowie bautechnischen Installationen sind nach den jeweils gültigen Normen bzw. Sicherheitsvorschriften in Ihrem Bundesland durchzuführen. Bitte setzen Sie bei Lichtquellen nur zulässige Leuchtmittelstärken ein. Bei Nichterhaltung der max. Wattzahl besteht durch Überhitzung Brandgefahr. Das Abdecken der Leuchtmittel ist wegen Brandgefahr zu unterlassen.</p> <p>Die einwandfreie Funktion des Möbels ist nur bei lot- und waagerechter Aufstellung gewährleistet. Die Türen sind vorjustiert, müssen aber ggf. aufgrund örtlicher Bedingungen neu ausgerichtet / eingestellt werden. Halten Sie bitte die Gewichtsangaben zur maximalen Belastung unbedingt ein. Möbel dürfen nicht bestiegen werden. Bei unsachgemäßem Gebrauch, kann es zu einem Umkippen von Möbelstücken kommen. Um dem vorzubeugen, sollten Möbel stets gegen Umkippen gesichert werden. Bei Überlastungen/Überbelastungen (insbesondere durch spielende Kinder, Menschen, Material oder sonstige unsachgemäße Einwirkungen) besteht Bruch- und Verletzungsgefahr. Alle Schrauben sowie tragende Verbindungsstellen sollten nach 5 bis 6 Wochen nachgezogen werden, um eine dauerhafte Standsicherheit zu gewährleisten.</p> <p>P F L E G E - Hinweise zur Möbelpflege- Beachten Sie bitte unsere Hinweise zur richtigen Möbelpflege, damit Sie möglichst lange Freude an unserem Produkt haben. Verwenden Sie bei der Reinigung ein sauberes, trockenes und weiches Baumwolltuch. Wenn Ihre Möbel einer gründlichen Reinigung bedürfen, können Sie das Tuch mit etwas Wasser oder Möbelreinigungsmittel befeuchten und anschließend die gereinigten Elemente trocknen. Metall- und Glasteile reinigen Sie am besten mit den handelsüblichen Metall- und Glasreinigern nach den auf ihnen befindlichen Pflegeanweisungen. Die Reinigungsmittel müssen einen klaren Hinweis tragen, dass sie zur Möbelpflege geeignet sind. Verwenden Sie auf gar keinen Fall Dampfweiger sowie ätzende, scheuende und andere Mittel, deren Wirkung Sie nicht kennen.</p> <p>A C H T U N G: Hochglanzoberflächen sind bei der Auslieferung durch eine Schutzfolie geschützt. Belassen Sie diese auf dem Möbel, bis es vollständig montiert und von Staub befreit ist. Hochglanzelemente, von denen die Schutzfolie entfernt wurde, dürfen erst nach 72 Stunden (Zeit zum Nachhärtan an der Raumluft) gereinigt und verwendet werden. Oberflächen nicht mit scharfen Gegenständen beschädigen und keinesfalls starker Sonnenbestrahlung aussetzen.</p> <p>E N T S O R G U N G - Hinweise zur Abfallsorgung- Der Umwelt zuliebe entsorgen Sie bitte den Verpackungsmüll sortenrein in die dafür vorgesehenen Abfall-/ Recyclingtonnen und nicht in die Natur. Beschädigte oder unbrauchbare Möbel können speziellen Wiederverwertungsanlagen zum Recyceln von Einzelteilen zugeführt werden.</p> <p>Ausgediente, jedoch noch funktionstüchtige Möbel müssen nicht gleich entsorgt werden. Spenden Sie sie z. B. an wohltätige Organisationen.</p> <p>Wir wünschen Ihnen viel Freude mit Ihrem neuen Möbel.</p>	<p>Уважаеми клиенти, благодарим Ви, че закупихте мебели от нашата интериорна програма за обзавеждане на дома. Моля, проверете обхвата на доставката за пълнота, преди монтажа прочетете внимателно следната важна информация и я запазете за бъдещи справки, а също и за трети страни. Нашите мебели следва да се използват по предназначение. Неправилната употреба може да доведе до материални щети или при определени обстоятелства до физически наранявания. Мебелите не са детски играчки. Производителят или търговецът не поема отговорност за щети в резултат на употреба извън предназначението или неправилно боравене.</p> <p>В Н И М А Н И Е: Деца или лица с ментални увреждания следва винаги да се държат далече от части на мебелите, остри предмети, малки части и опаковъчни материали, съществува опасност от нараняване и/или задущаване.</p> <p>М О Н Т И Р А Н Е: Во време на монтажа, моля, съблюдавайте нашите ръководства за експлоатация, обслужване, инсталиране или спобявяне и обърнете особено внимание на предупрежденията и указанията за безопасност. Неспазването на указанията може да доведе до нараняване на лица или повреда на мебелите / да създаде риск за безопасността. Ако имате затруднения при събляването / монтажа, моля, свържете се с нашия сервизен екип. Той е на Ваше разположение със съвети и действия. Монтажът следва да се извършва само от квалифицирани лица. Не се поема отговорност за щети в случай на модификации на продукта/части на продукта, при подмяна или използване на части / консумативи, които не са предоставени от производителя/търговеца.</p> <p>Ако към изделията са приложени крепежни елементи за стена, като дюбели и винтове, те са предназначени за използване само за стени от масивни и еднородни материали. Закрепването е толкова добро, колкото е добра връзката между крепежния елемент и стената. Моля, проверете пригодността на Вашата стена преди закрепването както на стоящи, така и на окачени мебели и използвайте само подходящи крепежни елементи. Преди да започнете с пробиването, се уверете, че в съответната зона не преминават кабели. По принцип монтажникът е отговорен за закрепването към стената.</p> <p>Това се отнася и за инсталирането на електрически артикули и структурното окабеляване. Монтирането / инсталирането на електрически артикули, както и на други конструктивни елементи, свързани със строителството, следва да се извършва само от оторизиран специализиран персонал. Всички електрически инсталации и структурно окабеляване следва да се изпълняват в съответствие с приложимите стандарти и разпоредби за безопасност във Вашата страна. Моля, използвайте само източници на светлина с допустимите стойности за сила на светлината. При неспазване на максималната мощност съществува опасност от пожар поради прегряване. Покриването на източниците на светлина не е разрешено поради опасност от пожар.</p> <p>Правилната функция на мебелите е гарантирана само при вертикално и хоризонтално положение. Вратите са регулирани предварително, но при необходимост в зависимост от местните условия може да се наложи да бъдат настроени/регулирани повторно. Моля, съблюдавайте стриктно спецификациите за максималното напрежение. Мебелите не са средство за катерене. При неправилна употреба мебелите могат да се преобърнат. За да се предотврати това, мебелите винаги трябва да се обезопасяват срещу преобъртане. При претоварване/свъртоаване (по-специално поради играещи деца, хора, материали или други неподходящи въздействия) съществува опасност от счупване и нараняване. Всички винтове, както и носещите свързващи точки трябва да бъдат затегнати след 5 до 6 седмици, за да се осигури трайна стабилност.</p> <p>П О Д Р Ъ Ж К А: -Указания за поддръжка на мебелите- Моля, съблюдавайте указанията за правилна поддръжка на мебелите, за да можете да се наслаждавате на нашите продукти възможно най-дълго.</p> <p>За почистване използвайте чиста, суха и мека памучна кърпа. Ако Вашите мебели се нуждаят от основно почистване, можете да навлажните кърпата с малко вода или почистващ препарат за мебели и след това да подсушите почистените елементи. Метални и стъклени части се почистват най-добре със стандартни почистващи препарати за метал и стъкло съобразно посочените върху опаковките указания. Почистващите препарати трябва да са с ясно указание, че са подходящи за поддръжка на мебели.</p> <p>В никакъв случай не трябва да използвате парочистачка, корозивни, абразивни или други препарати, чието действие не Ви е познато.</p> <p>В Н И М А Н И Е: При експедицията повърхностите с висок гланц са защитени с предпазно фолио. Оставете го върху мебелите, докато те бъдат напълно монтирани и почистени от прах. Елементите с висок гланц, от които е отстранено предпазното фолио, могат да се почистват и използват едва след 72 часа (време за допълнително втвърдяване на въздух в помешението).</p> <p>Не повреждайте повърхностите с остри предмети и в никакъв случай не ги излагайте на силна слънчева светлина.</p> <p>О Т С Т Р А Н Я В А Н Е К А Т О О Т П А Д Ъ К -Указания за отстраняването като отпадък- За опазване на околната среда, моля, изхвърляйте опаковките, сортирани по вид, в предвидените контейнери за отпадък / рециклиране, а не в природата. Повредените или непотребните мебели могат да бъдат предадени в специални дела за оползотворяване и рециклиране на отделни части. Излезлите от употреба, но все още годни мебели не бива да се изхвърлят веднага. Дарете ги напр. на благотворителни организации.</p> <p>Пожелаваме Ви да се наслаждавате на новото обзавеждане.</p>	<p>Vážená zákaznice, vážený zákazník, děkujeme, že jste si zakoupili nábytek z našeho interiérového programu pro výhradní použití v soukromých prostorách. Zkontrolujte úplnost rozsahu dodávky a před montáží si pozorně přečtěte následující důležité informace a uchovávejte je pro pozdější využití/použití, a to i třetími osobami.</p> <p>Náš nábytek se musí používat podle předpisů. Používání v rozporu s předpisy může vést k věcným škodám a za jistých okolností také k zraněním osob. Nábytek není hračka. Za škody, které vzniknou použitím proti předpisům nebo nesprávnou manipulací, nepřijímáme žádnou odpovědnost.</p> <p>P O Z O R: Děti nebo osoby s mentálními postižením se musí neustále držet mimo dílů nábytku, špičatých předmětů, drobých částí a obalových materiálů, protože hrozí riziko zranění a/nebo udušení.</p> <p>M O N T Á Ž: Při montáži dodržujte náš návod k používání, obsluze, instalaci nebo montáži a dávejte hlavně pozor na výstražná a bezpečnostní pokyny. Pokud se nebudou dodržovat předpisy, může to mít za následek zranění osob nebo poškození nábytku / ohrožení bezpečnosti. Pokud byste měli potíže s instalací/montáží, kontaktujte náš servisní tým. Tento vám ochotně poradí a pomůže. Montáž smí provádět pouze kvalifikovaný personál. Při změnách na produktu/dílech produktu, při výměně nebo použití dílů/spotřebních materiálů, které nepocházejí od výrobce/prodejce, nepřijímáme žádnou odpovědnost za škody.</p> <p>Pokud jsou ke zboží přiloženy upevňovací prvky na zeď, jako jsou hmoždinky a šrouby, jsou tyto určeny výhradně pro použití na stěnách z pevných a jednotných materiálů. Upevnění je jen tak dobré, jak dobré je spojení mezi upevňovacími prostředky a stěnou. Před upevněním musíte zkontrolovat vhodnost vaší stěny pro stáčení i závěsný nábytek a použít pouze vhodné spojovací prvky. Před případným vrtáním se ujistěte, že se v oblasti vrtání nenachází elektrické vodiče. Nakonec je za upevnění na stěnu odpovědný instalační technik.</p> <p>Plati to také pro instalaci elektrických produktů a dalšího stavebně-technického příslušenství. Montáž/instalaci elektrických produktů a také dalšího důležitého konstrukčního příslušenství může provádět pouze autorizovaný kvalifikovaný personál. Veškeré elektrické a stavebně-technické instalace musí být provedeny v souladu s platnými normami a bezpečnostními předpisy ve vaší zemi. Pro světelné zdroje používejte pouze povolenou intenzitu osvětlení. Při neodržení max. počtu Watt hrozí riziko požáru v důsledku přehřátí. Překrytími svítidel není povoleno z důvodu rizika požáru. Dokonalá funkce nábytku je zaručena pouze při vertikální a horizontální instalaci. Dveře jsou předem nastavené, mohou se ale znovu seřídit/nastavit na základě místních podmínek.</p> <p>Dodržujte údaje o hmotnosti pro maximální zatížení. Na nábytek se nesmí ležet. Při neoborném použití může dojít k převrácení nábytku. Aby se tomu zamezilo, musí být nábytek neustále zajištěn proti převrácení. Při přetížení/nadměrném přetížení (zejména hrajícími si dětmi, lidmi, materiálem nebo jinými nevhodnými vlivy) hrozí riziko rozbití a zranění. Všechny šrouby a nosná spojovací místa by měla být dotazena po 5 až 6 týdnech, aby se zajistila trvalá stabilita.</p> <p>P Ě Č E: -Pokyny k péči o nábytek- Dodržujte naše pokyny pro správnou péči o nábytek, abyste si náš výrobek mohli užívat co nejdéle. Při čištění používejte čisté, suchý a měkký bavlněný hadřík. Pokud potřebuje váš nábytek důkladné vyčištění, můžete hadřík navlhčit trochu vody nebo čističico prostředkem na nábytek a pak vyčistěné věci vysušit. Kovové a skleněné díly se nejlépe čistí běžně dostupnými čisticími prostředky na kov a sklo podle pokynů, které jsou na nich uvedené. Na čisticích prostředcích musí být jasně uvedeno, že jsou vhodné k čištění nábytku. V žádném případě nepoužívejte parní čističe, žiraviny, abraziva nebo jiné prostředky, jejichž účinky neznáte.</p> <p>P O Z O R: Vysoce lesklé povrchy jsou při dodávce chráněny ochrannou fólií. Nechte fólii na nábytku, dokud nebude zcela smontován a zbaven prachu. Vysoce lesklé prvky, ze kterých byla odstraněna ochranná fólie, lze čistit a používat až po 72 hodinách (doba pro následné vytvrzení na okolním vzduchu). Povrchy nelze poškodit ostrými předměty a nikdy je nemůžete vystavovat silnému slunečnímu záření.</p>	<p>Dear valued customer, Thank you for purchasing furniture from our interior programme, exclusively for use in private rooms. Please check the delivery for completeness, carefully read the following important information prior to assembly and retain it for future use, also by third parties.</p> <p>Our furniture may only be used as intended. Improper use can cause damage to property, or personal injury under certain circumstances. Furniture is not a toy. The manufacturer or distributor assumes no liability for damage caused by unintended use or improper handling.</p> <p>ATTENTION: Children or persons with a mental disability must be kept away from furniture components, sharp objects, small parts and packaging materials at all times. There is a risk of injury and/or suffocation.</p> <p>ASSEMBLY: Please observe our operating, assembly or installation instructions for assembly and observe the warnings and safety instructions in particular. Failure to follow instructions may lead to personal injury or damage to the furniture, and can pose a safety risk. Please contact our service team if you have problems with setup/assembly. They will be happy to help you. Assembly may only be carried out by competent persons. No liability for damage is assumed in case of changes to the product/product components or the replacement/use of parts/consumables not provided by the manufacturer/distributor. If wall mounting materials such as dowels or screws are included with the product, these are intended exclusively for use on solid walls made of uniform materials. Attachment is only as good as the connection between the mounting materials and the wall. For both standing and hanging furniture, check your wall for suitability prior to attachment and only use suitable mounting materials. Ensure there are no lines in the drilling zone before drilling any holes. Ultimately, the installer is responsible for the attachment to the wall.</p> <p>This also applies to the installation of electrical appliances and other structural accessories. The assembly/installation of electrical appliances and other structural accessories must be performed exclusively by authorised, qualified personnel. All electrical and structural installations must be carried out according to the respective applicable standards and safety regulations in your federal state. Only use approved illuminants for light sources. There is a risk of overheating and fire if the maximum wattage is exceeded. Covering illuminants is prohibited due to the risk of fire.</p> <p>Proper functioning of the furniture requires plumb and horizontal alignment. The doors are pre-adjusted, but may have to be readjusted due to local conditions. Be sure to observe the weight specifications for maximum loads. Climbing on furniture is prohibited. Furniture may tip over in case of improper use. To prevent this, furniture should always be secured against tipping over. There is a risk of breakage and injury in case of overloading (in particular by playing children, people, materials or other prohibited loads). All screws and load-bearing connections should be re-tightened after 5 to 6 weeks to ensure permanent stability.</p> <p>CARE: - Notes on furniture care - Please observe our information on proper furniture care to ensure you can enjoy our product for a long time. Use a clean, dry, soft cotton cloth for cleaning. If your furniture is heavily soiled, you may moisten the cloth with some water or furniture cleaner and dry the cleaned elements afterwards. Metal and glass components are best cleaned with conventional metal and glass cleaners according to the instructions provided for them. The cleaning agents must be clearly identified as being suitable for furniture care. Do not use steam cleaners, corrosive, scouring cleaning agents or other cleaners with unknown effects under any circumstances.</p> <p>ATTENTION: High-gloss surfaces are covered by a protective film on delivery. Leave this on the furniture until it has been fully assembled and dusted. Once the protective film is removed, high-gloss elements may only be cleaned and used after 72 hours (time for post-curing in room air). Do not damage surfaces with sharp objects and never expose them to strong sunlight.</p> <p>DISPOSAL - Notes on waste disposal - For the good of the environment, please sort the packaging for disposal, use the waste/recycling bins provided and do not litter. Damaged or unusable furniture can be recycled by special facilities for the recycling of components. Discused furniture that is still functional does not have to be discarded. Consider donating it to a charitable organisation.</p> <p>We hope you enjoy your new furniture.</p>

ES	FR	HR	HU
<p>Estimado/a cliente: Le damos las gracias por haber adquirido un mueble de nuestra gama de interiores para uso exclusivo en espacios privados. Le rogamos que compruebe que el volumen de suministro esté completo, lea detenidamente la siguiente información importante antes del montaje y la conserve para su uso posterior, también por parte de terceros. Nuestros muebles deben utilizarse según el uso previsto. Un uso inadecuado puede provocar daños materiales o, en determinadas circunstancias, lesiones personales. Los muebles no son juguetes. El fabricante o el distribuidor no asumen ninguna responsabilidad por los daños causados por un uso no conforme al previsto o una manipulación incorrecta.</p> <p><b>CUIDADO:</b> Los niños o las personas con discapacidades mentales deben mantenerse siempre alejados de los muebles, los objetos afilados, las piezas pequeñas y los materiales de embalaje; existe riesgo de lesiones y/o asfixia.</p> <p><b>MONTAJE:</b> Para el montaje, siga nuestras instrucciones de uso, instalación o montaje y preste especial atención a las indicaciones de advertencia y seguridad. Si no se siguen las instrucciones, pueden producirse lesiones personales o daños en los muebles/riesgo de seguridad. Si tiene alguna dificultad durante el montaje/la instalación, póngase en contacto con nuestro equipo de atención al cliente. Este estará a su disposición para lo que necesite. El montaje solo debe realizarlo personas competentes. No se asume ninguna responsabilidad por daños en caso de modificaciones en el producto/las piezas del producto ni en caso de sustitución o uso de piezas/consumibles que no procedan del fabricante/distribuidor.</p> <p>Si la mercancía incluye fijaciones de pared, como tacos y tornillos, se utilizarán exclusivamente en paredes hechas con materiales sólidos y uniformes. Una fijación es tan buena como la conexión existente entre los elementos de fijación y la pared. Tanto para los muebles de pie como para los muebles altos, compruebe la idoneidad de la pared antes de fijarlos y utilice únicamente elementos de fijación adecuados. Si tiene que taladrar la pared, asegúrese de que no haya líneas de electricidad en la zona donde vaya a realizar los taladros. En última instancia, el instalador es responsable de la fijación a la pared.</p> <p>Este también se aplica a la instalación de aparatos eléctricos y otros accesorios de construcción. El montaje/la instalación de aparatos eléctricos y otros accesorios relevantes para la construcción corresponden exclusivamente a personal especializado y autorizado.</p> <p>Todas las instalaciones eléctricas y estructurales deben realizarse de acuerdo con las normas y reglamentos de seguridad aplicables en su región. Asegúrese de que las bombillas utilizadas para las fuentes de luz tengan siempre la intensidad permitida. Si no se respeta el número de vatios máx., existe peligro de incendio por sobrecalentamiento. Se prohíbe cubrir las bombillas debido al peligro de incendio que esto supone.</p> <p>El correcto funcionamiento del mueble solo está garantizado si se instala a plomo y en horizontal. Las puertas están preajustadas, pero deben volver a alinearse/ajustarse en caso necesario según las condiciones locales. Es imprescindible tener en cuenta las indicaciones sobre la carga máxima. Se prohíbe subir a los muebles. En caso de uso inadecuado, los muebles pueden volcarse. Para evitarlo, se recomienda asegurar siempre los muebles para que no se caigan. En caso de sobrecargas (especialmente, por niños jugando, personas, material u otros factores inadecuados), existe riesgo de rotura y lesiones. Se recomienda apretar todos los tornillos y todos los puntos de unión sometidos a carga cada 5 o 6 semanas para garantizar una estabilidad duradera.</p> <p><b>CUIDADO:</b> -Instrucciones para el cuidado de los muebles-</p> <p>Tenga en cuenta nuestras indicaciones sobre el correcto cuidado de los muebles para que pueda disfrutar de nuestro producto durante el mayor tiempo posible.</p> <p>Para la limpieza, utilice un paño de algodón limpio, seco y suave. Si sus muebles necesitan una limpieza a fondo, puede humedecer el paño con un poco de agua o limpiamuebles y secar los muebles una vez limpios. Para limpiar las piezas de metal y cristal, lo mejor es utilizar productos de limpieza para metal y cristal disponibles en el mercado siguiendo las instrucciones de cuidado que figuran en ellos. Los productos de limpieza deben indicar claramente que son aptos para el cuidado de muebles.</p> <p>No utilice nunca limpiadores de vapor ni productos corrosivos, abrasivos o de otro tipo cuyos efectos desconozca.</p> <p><b>CUIDADO:</b> Las superficies de alto brillo están protegidas por una película protectora en el momento de la entrega. Déjela en el mueble hasta que esté completamente montado y libre de polvo. Los elementos de alto brillo a los que se les ha retirado la película protectora solo pueden limpiarse y utilizarse después de 72 horas (tiempo de poscurado en aire ambiente).</p> <p>No dañará las superficies con objetos afilados ni exponerlas a la luz solar fuerte bajo ninguna circunstancia.</p> <p><b>ELIMINACIÓN:</b> -Instrucciones sobre la eliminación de residuos-</p> <p>Por el bien del medioambiente, le rogamos que deposite los residuos de los envases clasificados por tipo en los contenedores de basura/reciclaje previstos, y no en la naturaleza.</p> <p>Los muebles dañados o inutilizables pueden llevarse a puntos de recogida especiales para el reciclaje de sus distintos componentes.</p> <p>Los muebles que estén desgastados, pero sigan siendo funcionales no tienen por qué eliminarse. Puede llevarlos, por ejemplo, a organizaciones benéficas.</p>	<p>Chères clientes, chers clients, merci d'avoir acheté un meuble de notre gamme Espace intérieur pour l'usage exclusif dans des locaux privés. Veuillez vérifier que le contenu de la livraison est complet et lire attentivement les informations importantes ci-dessous avant le montage, et conservez-les soigneusement pour d'éventuelles applications/utilisations ultérieures, y compris par des tiers. Nos meubles doivent être utilisés de manière conforme à leur destination. Une utilisation non conforme à la destination peut entraîner des dommages matériels ou dans certains cas des préjudices corporels. Les meubles ne sont pas des jouets destinés aux enfants. Le fabricant ou le distributeur décline toute responsabilité pour des dommages résultant d'une utilisation non conforme ou d'une manipulation erronée.</p> <p><b>ATTENTION:</b> Les enfants et les personnes handicapées mentales doivent toujours être tenus à distance des éléments de mobilier, des objets pointus, des petites pièces et des matériaux d'emballage en raison d'un risque de blessure et/ou d'étouffement.</p> <p><b>MONTAGE:</b> Lors du montage, veuillez suivre notre mode d'emploi, nos instructions d'exploitation, d'installation ou de montage et respectez notamment les avertissements et consignes de sécurité. Le non-respect des consignes peut entraîner des blessures des personnes ou des endommagements du meuble, constituer un risque pour la sécurité. Si vous rencontrez des difficultés de montage/ assemblage, veuillez contactez notre équipe de service clientèle. Elle est à votre entière disposition pour vous aider et vous conseiller. Le montage doit être effectué uniquement par des personnes qualifiées. Aucune responsabilité ne peut être assumée pour des dommages résultant de modifications apportées au produit ou à des parties du produit, du remplacement ou de l'utilisation de pièces/de fournitures qui n'ont pas été acquises auprès du fabricant/ du distributeur. Lorsque le produit est accompagné d'éléments de fixation murale tels que des chevilles et des vis, ces éléments sont exclusivement destinés à être utilisés sur des murs en matériaux massifs et homogènes. Une fixation n'est bonne que si la liaison entre les éléments de fixation et le mur est bonne. Avant la fixation au mur de meubles, qu'ils soient posés verticalement ou suspendus, veuillez vérifier l'aptitude de votre mur à cet effet et n'utiliser que des moyens de fixation appropriés. Avant de procéder à des travaux de posement, assurez-vous qu'il n'y a pas de conduites dans la zone de percement. En dernier ressort, c'est le monteur qui est responsable de la fixation au mur. Cela concerne également l'installation d'appareils électriques et autres accessoires architectoniques.</p> <p>L'assemblage / l'installation d'appareils électriques et autres accessoires de construction ne doivent être effectués que par un personnel autorisé. Toutes les installations électriques et architectoniques doivent être exécutées dans le respect des normes et règles de sécurité en vigueur de votre Land. Concernant les luminaires, n'utilisez que des puissances d'ampoules autorisées. En cas de non-respect du wattage maximal, il existe un risque d'incendie par surchauffe. Il est interdit de recouvrir les ampoules en raison du risque d'incendie. Le fonctionnement sans problème du meuble n'est garanti qu'en cas d'installation verticale et horizontale. Les portes sont prérégulées, mais doivent être neu alignées / ajustées si nécessaire en fonction des conditions locales. Respectez impérativement les spécifications en matière de poids concernant la charge maximale. Il est interdit de monter sur les meubles. En cas d'utilisation non conforme, il peut arriver que les meubles basculent. Afin d'éviter ce risque, les meubles doivent toujours être sécurisés contre le basculement. Il existe un risque de rupture et de blessure en cas de surcharges/ sollicitations excessives (notamment causées par des enfants qui jouent, des personnes, du matériel ou d'autres influences inappropriées). Afin de garantir une stabilité durable, toutes les vis et les points de raccordement porteurs doivent être resserrés après 5 à 6 semaines.</p> <p><b>ENTRETIEN:</b> -Consignes d'entretien du mobilier- Veuillez respecter nos instructions pour l'entretien correct du meuble afin que vous profitez le plus longtemps possible de notre produit. Pour le nettoyage, utilisez un chiffon en coton propre, sec et doux. Si vos meubles ont besoin d'un nettoyage approfondi, vous pouvez humidifier le chiffon avec un peu d'eau et sécher ensuite les éléments nettoyés. Pour les parties en métal et en verre, il est préférable d'utiliser les produits de nettoyage usuels du commerce pour le métal et les vitres en respectant les conseils d'entretien indiqués sur ces produits. Ces produits de nettoyage doivent clairement porter la mention indiquant qu'ils sont appropriés pour l'entretien des meubles.</p> <p>N'utilisez en aucun cas de nettoyeur à vapeur, ni de produits corrosifs, abrasifs et autres produits dont vous ne connaissez pas les effets.</p> <p><b>ATTENTION:</b> -Lors de la livraison, les surfaces haute brillance sont protégées par un film de protection. Laissez-les sur le meuble jusqu'à ce qu'il soit entièrement monté et débarrassé de la poussière. Les éléments haute brillance dont le film protecteur a été enlevé ne doivent être nettoyés et utilisés qu'après 72 heures (temps de durcissement à l'air ambiant). Ne pas endommager les surfaces avec des objets acérés et ne les exposez en aucun cas à un rayonnement solaire intense.</p> <p><b>ÉLIMINATION:</b> -Consignes pour l'élimination des déchets- Afin de protéger l'environnement, veuillez éliminer les déchets d'emballage triés selon leur nature dans les poubelles de déchets/de recyclage et non dans la nature. Les meubles endommagés ou inutilisables peuvent être amenés dans des centres de récupération aux fins du recyclage des pièces détachées. Les meubles usagés, mais encore fonctionnels ne doivent pas être éliminés tout de suite. Faites-en un peu, ex. de associations de bienfaisance.</p>	<p>Poštovani, hvala vam na kupnji komada namještaja iz našeg asortimana za interiere i za uporabu u privatnim prostorima. Molimo provjerite imate li sve potrebne dijelove i pažljivo pročitate sljedeće važne informacije prije montaže te sačuvajte ove upute za kasniju upotrebu, također i za treće osobe.</p> <p>Naš namještaj treba se koristiti sukladno njegovoj namjeni. Nepravilna uporaba može dovesti do oštećenja imovine ili osobnih ozljeda. Namještaj nije dječja igračka. Proizvođač ili prodavač ne preuzima odgovornost za štetu uzrokovanu eventualnom nepravilnom uporabom ili rukovanjem.</p> <p><b>OPREZ:</b> Djecu ili osobe s intelektualnim teškoćama uvijek treba držati podalje od dijelova namještaja, šiljatih predmeta, sitnih dijelova i materijala za pakiranje jer postoji opasnost od ozljeda i/ili gušenja.</p> <p><b>MONTAŽA:</b> Tijekom montaže slijedite naše upute za rad, rad, instalaciju ili montažu i obratite posebnu pozornost na upozorenja i sigurnosne upute. Nepoštivanje uputa može dovesti do tjelesnih ozljeda ili oštećenja namještaja ili ugroziti vašu sigurnost. Ako imate poteškoća s postavljanjem / montažom, obratite se našem servisnom timu. Oni su vam na raspolaganju za savjete ili bilo kakvu pomoć. Montažu smiju izvoditi samo stručne osobe. Ne prihvaćamo odgovornost za štetu u slučaju promjena na proizvod/dijelovima proizvoda, zamjene ili uporabe dijelova/potrošnog materijala koji ne potječu od proizvođača/trgovaca.</p> <p>Ako su iz robu priloženi i zidni učvršćivači kao što su tiple i vijci, oni su namijenjeni isključivo za korištenje na zidovima od čvrstih i kompaktnih materijala. Učvršćenje je zadovoljavajuće ako je dobra veza između sredstva za učvršćivanje i zida. Molimo provjerite prikladnost vašeg zida za stojeci i viseći namještaj prije nego ga pričvrstite i koristite samo odgovarajuće učvršćivače. Prije radova na bušenju, provjerite da u području bušenja nema električnih vodova. U konačnici, instalater je odgovoran za pričvršćivanje na zid.</p> <p>Te također odnosi i na ugradnju električnih elemenata i drugih strukturnih dodataka. Montažu/instalaciju električnih elemenata i ostalih dodataka smije izvoditi samo ovlašteno stručno osoblje. Sve električne i strukturne instalacije moraju biti izvedene u skladu s važećim standardima i sigurnosnim propisima u vašoj državi. Za izvore svjetlosti koristite samo dopuštene jačine osvijetljenja. Ako se ne poštuje maksimalna snaga, postoji opasnost od požara zbog pregrijavanja. Pokrivanje svjetiljki nije dopušteno zbog opasnosti od požara.</p> <p>Savršena funkcija namještaja zajamčena je samo ako je postavljen okomito i vodoravno. Vrata su unaprijed podređena, ali će ih možda trebati ponovno poravnati/podesiti zbog lokalnih uvjeta. Molimo pridržavajte se specifičacija težine za maksimalno opterećenje. Penjanje na namještaj je zabranjeno. Nepravilno korištenje može dovesti do prevrtanja namještaja. Kako biste to spriječili, namještaj uvijek treba osigurati od prevrtanja. Postoji opasnost od loma i ozljeda u slučaju preopterećenja (osobito uslijed dječje igre, ljudi, materijala ili drugih neprikladnih utjecaja). Sve vijke i nosive spojnice točno potrebno je zategnuti nakon 5 do 6 tjedana kako bi se osigurala trajna stabilnost.</p> <p><b>ODRŽAVANJE:</b></p> <ul style="list-style-type: none"><li>-Napomene o njezi namještaja- Slijedite naše upute o pravilnoj njezi namještaja kako biste što dulje mogli uživati u našem proizvodu.</li><li>Prikladno čišćenje koristite čistu, suhu i meku pamučnu krp.</li><li>Ako vaš namještaj treba temeljito čišćenje, možete navlažiti krpu u malo vode ili sredstva za čišćenje namještaja, a zatim osušite očišćene predmete. Metalne i staklene dijelove najbolje je čistiti komercijalno dostupnim sredstvima za čišćenje metala i stakla prema priloženim uputama za njegu. Sredstva za čišćenje moraju imati jasnu naznaku o prikladnosti za čišćenje namještaja.</li><li>Ni u kojem slučaju ne smijete koristiti parne čistače, nagrizajuća, abrazivna ili druga sredstva ako niste sigurni u njihov način djelovanja.</li><li><b>OPREZ:</b> Površine visokog sjaja su pri isporuci zaštićene zaštitnom folijom. Ostavite ih na namještaju dok se potpuno ne sastavi i ne očisti od prašine. Elementi visokog sjaja s kojih je uklonjena zaštitna folija smiju se čistiti i koristiti tek nakon 72 sata (vrijeme naknadnog stvrdnjavanja na okolnom zraku).</li><li>Ne oštećujte površine oštrim predmetima i ne izlažite ih jakom suncu.</li></ul>	<p>Tisztelt Ügyfeleink! Köszönjük, hogy beltéri programunkban szereplő bútor vásárlása mellett döntött, amely kizárólag privát helyiségekben történő használatra készült. Ellenőrizze a szállításon hiánytalanságát, és figyelmesen olvassa el az alábbi fontos információkat az összeszerelés előtt, valamint tartsa meg ezeket későbbi használat céljából, bárki számára.</p> <p>Bütorárbjainkat rendeltetészerűen kell használni. A nem rendeltetészerű használat dologi károkat vagy bizonyos körülmények között személyi sérüléseket okozhat. A bútor nem játék. A gyártó vagy a kereskedő nem vállal felelősséget olyan károsodásokért, amelyek a nem rendeltetészerű használat vagy a helytelen kezelés miatt keletkeztek.</p> <p><b>FIELEME:</b> Gyerekek és szellemi fogyatékkal élő felntettek mindig távol kell tartani bútoralkatrészekétől, hegyes tárgyaktól, kisméretű alkatrészekétől és csomagolóanyagoktól. Sérülés- és fulladásveszély áll fenn.</p> <p><b>ÖSSZEZERELÉS:</b> Összeszereléskor nézze meg az utasításokat az üzemeltetés, kezelési, telepítési vagy szerelési útmutatóinkban, valamint különösen ügyeljen a figyelmeztetésekre és biztonsági utasításokra. Amennyiben nem tartja be az utasításokat, az személyi sérülést vagy bútorkárosodást eredményezhet/biztonsági kockázattá válhat. Amennyiben felépítéskor/összeszereléskor nehézségei vannak, forduljon szervizcsapatunkhoz. Mindig kézzel kell kezelni. A összeszerelést csak szakmálag hozzáértő személyek végezhetik el. A termék/termékrészek módosításai esetén, alkatrészek cseréjekor, illetve nem a gyártótól/kereskedőtől származó alkatrészek/fogyóanyagok használatakor a károsodásokért nem vállalunk felelősséget.</p> <p>Ha az áruhoz fali rögzítésszűközők, például dübök és csavarok vannak mellékelve, azok kizárólag erős és egységes anyagú falakon történő alkalmazásához valók. A rögzítés csak úgy megfelelő, amennyire a fal és a rögzítésszűköző közötti kapcsolat. Na csak áll, hanem felfüggesztett bútorok esetén is ellenőrizze azok fali rögzítés előtt, hogy azok erre alkalmasak-e, valamint csak ehhez megfelelő rögzítésszűközőket használjon. Esetleges furás munkák esetén bizonyosodjon meg róla, hogy a furás területén nincsenek vezetékek. Végeztül a szerelő felelős a falra történő rögzítésért.</p> <p>Ez az elektromos cikkek, valamint más építészeti tartozékok telepítésére is érvényes. Az elektromos cikkek, valamint más, építéshez kapcsolódó tartozékok összeszerelését/telepítését csak arra feljogosított szakemberek végezheti. Minden elektromos és építészeti telepítését az Önök országában hatályos vonatkozó szabványok, illetve biztonsági előírások szerint kell elvégezni. Fényforrások esetén csak megengedett izzőbőrségeket állíson be. A maximális teljesítmény be nem tartása esetén a túlmelegedés miatt tűzveszély áll fenn. A tűzveszély miatt az iztól tilos letakarni.</p> <p>A bútor kifogástalan működőképessége csak függőleges és vízszintes felállítás esetén biztosított. Az ajtók előzetesen be vannak állítva, de szükség esetén a helyi körülményeknek megfelelően újra beállíthatók/beigazíthatók. Feltétlenül tartsa be a maximális terhelésre vonatkozó súlyadatokat. A bútorokra tilos felmászni. Szakszerűtlen kezelés esetén a bútordarabok felborulhatnak. Ennek megelőzése érdekében be a bútorokat mindig biztosítani kell felállítás ellen. Túlerősítés/fűzőtt igénybevétele esetén (különösen játszó gyerekek, emberek, anyag vagy egyéb szakszerűtlen behatások miatt) törés- és sérülésveszély áll fenn. Minden csavaron, valamint terhelőnkre kapcsolódóan helyen 5-6 héig utánhúzást kell végezni, a tartósan biztos rögzítés biztosítása céljából.</p> <p><b>POLAS:</b> -Bútorápolási utasítások-</p> <p>Vegye figyelembe a helyes bútorápolásra vonatkozó utasításainkat, hogy a lehető leghosszabb ideig örömet leljék munkánkban.</p> <p>Tisztítsuk tisztá, száraz, puha pamutkendő használjón. Ha bútor alaposabb tisztítást igényel, akkor a kendőt kevés vízzel vagy bútorápoló szerrel megnedvesítheti, végül a megisztított elemeket szárítsa meg. A fém- és üvegalkatrészeket a legjobb, ha kereskedelmi forgalomban kapható fém- és üveg tisztítószerrel, a rajtuk szereplő ápolási útmutatóknak megfelelően tisztítja. A tisztítószernek rendelkeznie kell egyértelmű utalással arra vonatkozóan, hogy a szer bútorápolásra megfelelő.</p> <p>Semmilyen körülmények között se használjon gőzölős tisztító, se maró, dörzsölő hatású, vagy egyéb olyan szert, amelynek nem ismeri a hatását.</p> <p><b>FIELEME:</b> A magasfényű felületeket kiszállítókor védőfólia óvja. Ezeket addig hagyja rajta a bútoron, amíg azt teljesen össze nem szerelik, és nem portalanítják. A magasfényű elemeket, amelyekről eltávolították a védőfóliát, csak 72 óra elteltével (a helyiség levegőjén történő utólagos keményedés ideje) szabad tisztítani vagy használni.</p> <p>Ne sértsé meg a felületeket éles tárgyakkal, és soha ne tegye ki erős napfénytámadásnak.</p> <p><b>HULLADÉKKEZELÉS:</b> Hulladékkézelésre vonatkozó tudnivalók- A környezet védelme céljából a csomagolási hulladékot fájta szerint szétválogatva tegye az arra szolgáló hulladékgyűjtőbe/újrahasznosító konténerbe, ne a természetbe dobja.</p> <p>A sérült vagy használhatatlan bútor arra kijelölt újrahasznosító létesítményben adja le, ahol az egyes alkatrészeit újrahasznosítják.</p> <p>A leselejtezett, de még használható bútorokat nem kell azonnal a hulladéka kidobni. Adományként leadhatja pl. játékonysági szervezeteknél.</p>

IT	NL	PL	RO
<p>Gentile cliente, ti ringraziamo per aver acquistato un mobile della nostra gamma di interni ad uso esclusivo per locali privati. Prima di procedere all'installazione ti preghiamo di verificare la completezza della fornitura, leggere attentamente le informazioni essenziali riportate di seguito e conservare l'apposito manuale per un uso successivo, anche da parte di terzi.</p> <p>I nostri mobili devono essere utilizzati secondo lo scopo previsto. L'uso improprio può causare danni materiali o lesioni personali. I mobili non sono adatti per fu giocare i bambini. Pertanto il produttore o il rivenditore non si assume alcuna responsabilità per danni causati da un uso improprio o da una manipolazione errata.</p> <p>ATTENZIONE: tenere lontano bambini e persone affetti da disabilità intellettive da componenti dei mobili, oggetti appuntiti, minuterie e materiali di imballaggio, poiché sussiste il rischio di lesioni e/o soffocamento.</p> <p>MONTAGGIO: durante il montaggio, attenersi alle istruzioni operative, di funzionamento, di installazione o montaggio da noi rilasciate e prestare particolare attenzione alle avvertenze e alle indicazioni in materia di sicurezza.</p> <p>L'inosservanza delle istruzioni può causare lesioni personali o danni ai mobili/nivelarsi un pericolo ai fini della sicurezza.</p> <p>In caso di difficoltà con l'assemblaggio/il montaggio, contattare il nostro team di assistenza che sostiene l'utente fornendogli consigli e iniziative da intraprendere. Il montaggio è consentito esclusivamente al personale competente. Pertanto non ci assumiamo responsabilità per danni causati da modifiche al prodotto/alte parti del prodotto, sostituzione o utilizzo di parti/materiali di consumo che non vengano effettuate dal produttore/rivenditore.</p> <p>Qualora la fornitura della merce comprenda elementi di fissaggio a parete come tasselli e viti, tali elementi sono destinati esclusivamente all'uso su pareti realizzate con materiali solidi e uniformi. Un fissaggio è da considerarsi buono tanto quanto il collegamento tra l'elemento e la parete. Verificare pertanto l' idoneità della parete sia per i mobili da terra o a sospensione prima di eseguire il fissaggio e utilizzare solo elementi di fissaggio adeguati. Prima di eventuali lavori di perforazione, assicurarsi che non vi siano cavi nell'area interessata. Sostanzialmente, l'installatore si assume la responsabilità del fissaggio alla parete.</p> <p>Cio vale anche per l'installazione di articoli elettrici e altri accessori strutturali. Il montaggio/l'installazione di articoli elettrici e altri accessori correlati all'edilizia è consentito esclusivamente a specialisti autorizzati. Tutte le installazioni di tipo elettrico e ingegneristico devono essere eseguite conformemente agli standard e alle normative di sicurezza applicabili nel proprio stato. Per le sorgenti luminose, utilizzare solo la potenza consentita. Se il wattaggio massimo non viene rispettato, è possibile l'insorgere di incendi per surriscaldamento. Non è consentito coprire le lampadine poiché ciò provocherebbe un pericolo di incendio.</p> <p>La perfetta funzionalità del mobile è garantita solo se è posizionato in verticale o in orizzontale. Le porte sono pre-allineate, ma potrebbe essere necessario un riallineamento o una regolazione in base alle condizioni locali. Attenersi alle specifiche di peso per il carico massimo. Non è consentito arrampicarsi ai mobili. Un uso improprio potrebbe causare il ribaltamento. Per evitare ciò, mettere al sicuro i mobili da eventuali ribaltamenti. In caso di sovraccarichi/sollecitazioni sussiste il rischio di infortuni e di lesioni (in particolare a causa di bambini che giocano, persone, materiali o impieghi di altra natura inappropriati). Tutte le viti e i punti di collegamento portanti devono essere nuovamente serrati dopo 5-6 settimane al fine di garantire una stabilità permanente.</p> <p>MANUTENZIONE: -Note sulla cura dei mobili-</p> <p>Prestare attenzione alle nostre informazioni sulla corretta cura dei mobili in modo da poter garantire il più possibile una lunga durata del prodotto.</p> <p>Per la pulizia, utilizzare un panno di cotone pulito, asciutto e morbido. Se i mobili necessitano di una pulizia accurata, è possibile inumidire il panno con un po' d'acqua o un detergente per mobili e poi asciugare gli elementi puliti. È più conveniente pulire le parti in metallo e vetro con adeguati detersivi disponibili in commercio secondo le istruzioni per la manutenzione disponibili. I detersivi devono recare una chiara indicazione della loro idoneità alla pulizia dei mobili.</p> <p>È vietato utilizzare pulitori a vapore, caustici, abrasivi o altri agenti dei quali non si conoscono gli effetti.</p> <p>ATTENZIONE: al momento della consegna le superfici lucide sono protette da una pellicola protettiva. Lasciare la pellicola sul mobile finché non è completamente assemblato ed esente di polvere. Sol tanto dopo 72 ore (periodo di post-polymerizzazione nell'aria ambiente) sarà possibile pulire e utilizzare gli elementi lucidi dai quali è stata rimossa la pellicola protettiva.</p> <p>Non danneggiare le superfici con oggetti appuntiti e non esporle mai a forti irraggiamenti solari.</p> <p>SMALTIMENTO -Note sullo smaltimento dei rifiuti-</p> <p>Per il bene dell'ambiente, è necessario smaltire i rifiuti di imballaggio differenziati per tipologia negli appositi cassonetti per rifiuti e non disperderli in natura.</p> <p>I mobili danneggiati o inutilizzabili possono essere inviati presso degli impianti speciali di trattamento per il riciclaggio delle singole parti.</p> <p>I mobili in disuso ma ancora funzionali non devono essere smaltiti immediatamente. È possibile donarli, ad esempio, a degli enti di beneficenza.</p> <p>Ci auguriamo che ti possa trovare bene con il nostro prodotto.</p>	<p>Geachte klant, Bedankt voor de aankoop van een meubel uit ons interieurassortiment voor exclusief gebruik in privéruimten. Gelieve de levering te controleren op volledigheid en lees de volgende belangrijke informatie aandachtig vóór de installatie en bewaar deze voor later gebruik, ook door derden.</p> <p>Onze meubelen dienen te worden gebruikt waarvoor ze bedoeld zijn. Onbedoeld gebruik kan leiden tot materiële schade of persoonlijke letsels. Meubels zijn geen kinderspeelgoed. De fabrikant of handelaar aanvaardt geen aansprakelijkheid voor schade veroorzaakt door onbedoeld gebruik of onjuiste hantering.</p> <p>OPGELET: Houd kinderen of mensen met een verstandelijke beperking altijd uit de buurt van meubelonderdelen, puntige voorwerpen, kleine onderdelen en verpakkingsmaterialen, omdat er gevaar voor letsel en/of verstikking bestaat.</p> <p>MONTAGE: Volg tijdens de montage onze gebruiksi-, bedienings-, installatie- of montage-instructies en let in het bijzonder op waarschuwingen en veiligheidsinstructies. Het niet opvolgen van de instructies kan leiden tot persoonlijke letsels of schade aan meubels of een veiligheidsrisico opleveren. Indien je problemen hebt met de installatie/montage, neem dan contact op met ons serviceteam. Dit staat steeds aan je zijde met raad en daad. De montage mag alleen worden uitgevoerd door bevoegde personen. Wij zijn niet aansprakelijk voor schade bij wijzigingen aan het product/de productonderdelen, bij vervanging van onderdelen of gebruik van onderdelen/verbruiksartikelen die niet afkomstig zijn van de fabrikant/handelaar.</p> <p>Indien de goederen verzegeld gaan van wandbevestigingen zoals pluggen en schroeven, zijn deze uitsluitend bestemd voor gebruik op wanden uit massieve en uniforme materialen. Een bevestiging is maar zo stevig als de verbinding tussen het bevestigingsmiddel en de wand. Controleer de geschiktheid van je wand bij zowel staande als hangende meubels voordat je deze bevestigt en gebruik alleen geschikte bevestigingsmiddelen. Zorg er vóór je gaat boren voor dat er zich geen kabels in het boorgebied bevinden. Uiteindelijk is de installateur verantwoordelijk voor de bevestiging aan de muur.</p> <p>Dit geldt ook voor de installatie van elektrische apparaten en andere structurele accessoires. De montage/installatie van elektrische apparaten en andere bouwgerelateerde accessoires mag alleen gebeuren door bevoegd vakpersoneel. Alle elektrische en structurele installaties moeten worden uitgevoerd in overeenstemming met de geldende normen en veiligheidsvoorschriften in je land. Gebruik voor lichtbronnen alleen toegestane lichtsterkten. Indien het maximale wattage niet in acht wordt genomen, is er een risico op brandgevaar door oververhitting. Het is vanwege brandgevaar niet toegestaan lampen af te dekken. De correcte werking van het meubel is alleen gegarandeerd wanneer het verticaal en horizontaal loodrecht is opgesteld. De deuren zijn vooraf afgesteld, maar moeten mogelijk worden uitgelijnd/afgesteld vanwege lokale omstandigheden. Hou je aan de gewichtsspecificaties voor de maximale belasting. Meubels mogen niet worden beklommen. Onbedoeld gebruik kan ertoe leiden dat meubels omkantelen. Om dit te voorkomen, moeten meubels altijd worden beveiligd tegen omkantelen. Bij overbelasting (met name door spelende kinderen, mensen, materiaal of andere oneigenlijke invloeden) bestaat gevaar voor materiële schade en persoonlijke letsels. Alle schroeven en dragende verbindingen moeten na 5 tot 6 weken worden aangedraaid om een blijvende stabiliteit te garanderen.</p> <p>ONDERHOUD: -Opmerkingen over meubelonderhoud-</p> <p>Leef onze tips voor het juiste meubelonderhoud na, zodat je zo lang mogelijk van ons product kunt genieten. Gebruik bij het schoonmaken een schone, droge en zachte katoenen doek. Als je meubels een grondige reiniging nodig hebben, kun je de doek vochtig maken met een beetje water of meubelreiniger en daarna de schoongemaakte elementen droog maken. Metalen en glazen onderdelen reinig je het beste met in de handel verkrijgbare metaal- en glasreinigers volgens de onderhoudsinstructies die erop staan vermeld. Op de schoonmaakmiddelen moet duidelijk zijn vermeld dat ze geschikt zijn voor het onderhoud van meubelen.</p> <p>Gebruik in geen geval stoomreinigers, bijtende, schurende of andere middelen waarvan je het effect niet kent.</p> <p>OPGELET: Hoogglansoppervlakken worden bij de levering beschermd door een beschermfolie. Laat deze op het meubel totdat dit volledig gemonteerd en stofvrij is. Hoogglanselementen waarvan de beschermfilm is verwijderd, mogen pas na 72 uur worden gereinigd en gebruikt (na-uithardingstijd in omgevingslucht).</p> <p>Beschadig oppervlakken niet met scherpe voorwerpen en stel deze nooit bloot aan sterk zonlicht.</p> <p>VERWIJDERING -Opmerkingen over afvalverwerking-</p> <p>Deponeer het verpakkingsafval milieubewust gesorteerd in de daarvoor bestemde afval-/recyclingbakken en niet in de natuur.</p> <p>Beschadigde of onbruikbare meubels kunnen naar speciale inzamelpunten worden gebracht voor de recycling van afzonderlijke onderdelen.</p> <p>Afgedankte maar nog steeds functionele meubelen hoeven niet meteen te worden weggegooid. Doneer deze b.v. aan goede doelen.</p> <p>Wij wensen je veel plezier met je nieuwe meubel.</p>	<p>Szanowni Klienci, Szanowny Kliencie, dziękujemy za zakup mebla z naszej wntęrzarskiej oferty do wyłączonego użyciu w pomieszczeniach prywatnych. Prosimy sprawdzić dostawę pod kątem kompletności oraz uważnie przeczytać poniższe ważne informacje przed montażem i zachować je do późniejszego wykorzystania, również przez osoby trzecie.</p> <p>Nasze meble należy użytkować zgodnie z przeznaczeniem. Użytkowanie niezgodne z przeznaczeniem może skutkować uszkodzeniem mebla lub też, w niektórych przypadkach, do obrażeń ciała. Meble nie są zabawkami dla dzieci. Producent ani sprzedawca nie ponoszą odpowiedzialności za szkody, powstałe w wyniku użytkowania niezgodnego z przeznaczeniem lub niewłaściwego stosowania.</p> <p>U W A G A: Dzieci lub osoby z niesprawnością umysłową należy zawsze chronić przed częściami mebli, ostrymi przedmiotami, drobnymi elementami i materiałami opakowaniowymi, ponieważ istnieje ryzyko powstania obrażeń i/lub uduszenia.</p> <p>M O N T A Ż: Podczas montażu należy stosować się do naszych instrukcji obsługi, użytkowania, instalacji i montażu ze szczególnym uwzględnieniem ostrzeżeń i wskazówek dotyczących bezpieczeństwa. Nieprzestrzeganie wskazówek może prowadzić do powstania obrażeń ciała lub uszkodzenia mebli / stać się zagrożeniem dla bezpieczeństwa. W razie problemów ze składaniem / montażem prosimy o kontakt z naszym działem serwisowym. Służmy Państwu radą i pomocą. Montażu może dokonywać wyłącznie kompetentny personel. Nie ponosimy odpowiedzialności za szkody w przypadku wprowadzenia zmian w produkcie/części produktu, wymiany lub zastosowania części / materiałów eksploatacyjnych, które nie pochodzą od producenta/sprzedawcy.</p> <p>Ewentualnie dołączone do towaru mocowania ścienne, takie jak kołki i wkręty, przeznaczane są wyłącznie do stosowania na ścianach wykonanych z solidnych i jednolitych materiałów. Montaż jest na tyle solidny, na ile solidne jest połączenie między mocowaniem a ścianą. Przed przycumowaniem stojących i wiszących mebli należy najpierw sprawdzić, a czy dana ściana się do tego nadaje, a także używać wyłącznie odpowiednich mocowań. Przed przystąpieniem do ewentualnego wiercenia należy się upewnić, że w obszarze wiercenia nie przebiegają przewody. Docelowo to montażysta odpowiada za mocowanie do ściany.</p> <p>Dotyczy to też instalacji artykułów elektrycznych oraz innych elementów konstrukcyjnych. Montażu / instalacji artykułów elektrycznych oraz innych elementów konstrukcyjnych może dokonywać wyłącznie autoryzowany personel specjalistyczny. Wszelkie instalacje elektryczne i konstrukcyjne muszą być wykonane zgodnie z obowiązującymi normami i przepisami bezpieczeństwa w Państwa kraju. W przypadku źródeł światła należy stosować wyłącznie dozwolone natężenie światła. Przekroczenie maksymalnej mocy stwarza ryzyko pożaru z powodu przegrzania. Zasilanie lamp jest zabronione ze względu na ryzyko pożaru.</p> <p>Prawidłowe funkcjonowanie mebla jest gwarantowane tylko w przypadku jego prawidłowego pionowego i poziomego ustawienia. Drzwi zostały wstępnie wyregulowane, ale ze względu na warunki lokalne należy je ewentualnie ustawić na nowo / wyregulować! Należy przestrzegać informacji dotyczących wagi dla maksymalnego obciążenia. Nie wolno wpiąć się na meble. Niewłaściwe użytkowanie może spowodować przewrócenie się mebli. Aby temu zapobiec, meble należy zawsze zabezpieczyć przed przewróceniem. W przypadku przecięcia/łamięcia nadmiernego obciążenia (w szczególności z powodu bawiących się dzieci, ludzi, materiałów lub innych niewłaściwych wpływów) istnieje ryzyko zlamania i obrażeń. Wszystkie śruby i nośne elementy łączące należy dokręcić po 5-6 tygodniach, aby zapewnić trwałą stabilność.</p> <p>P I E L E G N A C J A -Wskazówki dotyczące pielęgnacji mebli- Należy przestrzegać naszych wskazówek dotyczących właściwej pielęgnacji mebli, aby móc jak najdłużej cieszyć się naszym produktem.</p> <p>Do czyszczenia używać czystej, suchej i miękkiej ściereczki bawełnianej. Jeśli meble wymagają gruntownego czyszczenia, mogą Państwo zgodnie z ściereczką wodą lub środkiem do czyszczenia mebli, a następnie osuszyć czyszczące elementy. Elementy metalowe i szklane najlepiej czyścić używając dostępnych na rynku środków do czyszczenia metalu i szkła, zgodnie z zamieszczonymi na nich instrukcjami zastosowania. Środki czyszczące muszą zawierać wyraźną informację, że są one przeznaczone do czyszczenia mebli. W żadnym wypadku nie należy używać środków do czyszczenia parą, żrących, ściernych ani innych środków, których działanie nie jest znane.</p> <p>U W A G A: Powierzchnie o wysokim połysku są na czas transportu zabezpieczone folią ochronną. Folie należy pozostawić na meblu do czasu jego całkowitego montażu i usunięcia z niego pyłu. Elementy o wysokim połysku, z których usunęto folię ochronną można czyścić i użytkować dopiero po 72 godzinach (czas twardnienia w powietrzu otoczenia).</p> <p>Nie uszkodzić powierzchni ostrymi przedmiotami, a w szczególności nie wystawiać a działaniu silnych promieni słonecznych.</p> <p>U T Y L I Z A C J A -Wskazówki dotyczące utylizacji-</p> <p>W trosce o przyrodę prosimy utylizować materiały opakowaniowe z zastosowaniem segregacji odpadów wyrzucając je do odpowiednich pojemników na odpady / materiały recyklingowe, nie zaś bezpośrednio do środowiska naturalnego.</p> <p>Uszkodzone lub nienadające się do użytku meble można przekazać do specjalnych zakładów odzysku w celu recyklingu poszczególnych części.</p> <p>Używanych, ale nadal nadających się do użytku mebli nie należy wyrzucać od razu wyrzucąc. Można przekazać je na przykład organizacjom charytatywnym.</p> <p>Życzymy wiele zadowolenia z Państwa nowego mebla.</p>	<p>Stimată clientă, stimate client, îți mulțumim pentru achiziția unei piese de mobilier din programul nostru de interior pentru utilizarea exclusivă în încăperi private. Vă rugăm să verificați integralitatea volumului livrării și să citiți cu atenție informațiile importante de mai jos înainte de montajului și să le păstrați pentru utilizarea ulterioară, inclusiv de către terți.</p> <p>Piesele noastre de mobilier trebuie să fie folosite conform destinației. Utilizarea neconformă destinației poate cauza daune materiale sau în anumite circumstanțe vătămări corporale. Piesele de mobilier nu sunt jucării. Producătorul sau comerciantul nu își asumă răspunderea pentru daune, care sunt provocate prin utilizarea neconformă destinației sau prin manipulare greșită.</p> <p>A T E N T I E: Copiii și persoanele cu handicap psihic trebuie să fie ținute întotdeauna la distanță față de piese de mobilier, obiecte ascuțite, piese mici și materiale de ambalaj, există pericolul de vătămare și/sau asfixiație.</p> <p>M O N T A J: Pentru montaj, vă rugăm să vă orientați după instrucțiunile noastre de funcționare, de operare, de instalare sau de montaj și să respectați în special avertismentele și indicațiile de siguranță. Dacă instrucțiunile nu au fost respectate, acest fapt poate să provoace leziuni la persoane sau daune la mobilier / pot să devină un risc de siguranță. Dacă aveți dificultăți la asamblare / montaj, vă rugăm să contactați echipa noastră de service. Această vă stă alături cu sfaturi și asistență. Montajul poate fi efectuat numai de către persoane calificate. În cazul modificării lor produs/piese ale produsului, în cazul schimbării, respectiv al înlocuirii pieselor / materialelor de consum, care nu provin de la producător/comerciant, nu se poate prelucra nicio răspundere pentru daune.</p> <p>Dacă marfa include mijloace de montare pe perete, precum dibluri și șuruburi, acestea sunt destinate exclusiv pentru utilizarea la pereți din materiale masive și uniforme. O fixare este numai așa de bună ca legătura dintre mijlocul de fixare și perete. Vă rugăm să verificați atât în cazul pieselor de mobilier de pe sine stătătoare cât și al celor suspendate, înainte de fixarea lor, utilizați dumneastra să privesc la adeverirea în acest sens și puteți numai mijloacele de montare adecvate. Înaintea eventualelor lucrări de găurire, asigurați-vă că nu se află cabluri în zona de găurire. În final, montatorul este responsabil pentru fixarea sigură de perete. Această privește și instalarea articolelor electrice, precum și celelalte accesorii tehnice constructive. Montarea / instalarea articolelor electrice, precum și a altor accesorii relevante constructiv trebuie să fie efectuate numai de personal calificat autorizat. Toate instalațiile electrice, precum și tehnice constructive trebuie să fie executate conform standardelor respective valabile, respectiv normelor de siguranță din țara dumneastra. Pentru sursele de lumină vă rugăm să folosiți numai intensitățile admisiibile ale corpurilor de iluminat. În cazul nerespectării normului max. de Watt există pericol de incendiu din cauza supraîncălzirii. Trebuie să se omită acoperirea corpurilor de iluminat din cauza pericolului de incendiu.</p> <p>O funcționare perfectă a mobilierului este garantată numai în cazul unei amplasări verticale și orizontale. Ușile sunt ajustate în prealabil, însă trebuie eventuale aliniate / reglate din nou din cauza condițiilor locale. Vă rugăm să respectați neapărat indicațiile de greutate privind sarcina maximă. Nu este permis să urcați pe mobilă. În cazul utilizării necorespunzătoare, poate să apară răsturnarea pieselor de mobilier. Pentru a preveni acest fapt, piesele de mobilier ar trebui asigurate întotdeauna împotriva răsturnării. În cazul supraîncălzirii/supraîncălzirii (în special prin copii care se joacă, oameni, materiale sau alte acțiuni necorespunzătoare), există pericolul de rupere și leziune. Toate șuruburile, precum și punctele de îmbinare portante ar trebuie strânse din nou după 5 până la 6 săptămâni, pentru a asigura o stabilitate permanentă.</p> <p>Î N G R I J I R E -Indicații de îngrijire a mobilier-</p> <p>Vă rugăm să respectați indicațiile noastre cu privire la îngrijirea corectă a mobilier, astfel încât să vă bucurați cât de mult posibil de produsul nostru.</p> <p>Pentru curățare, utilizați o lavetă de bumbac curată, uscată și moale. Dacă mobilierul dumneastra necesită o curățare temeinică, puteți să utilizați laveta cu puțină apă sau soluție de curățare a mobilier și apoi să uscați elementele curățate. Cel mai bine curățați piesele din metal și sticlă cu soluții de curățare a metalului și a sticlei uzuale din comerț conform instrucțiunilor de îngrijire de pe acestea. Soluțiile de curățare trebuie să poarte o indicație clară că sunt adecvate pentru îngrijirea mobilier.</p> <p>În niciun caz nu folosiți aparate de curățare cu abur, precum și substanțe caustice, abrazive sau alte substanțe al căror efect nu îl cunoașteți.</p> <p>A T E N T I E: Suprafețele lucioase sunt protejate printr-o folie la livrare. Lăsați-o pe mobilă, până când este montată complet și curățată de praf. Elementele lucioase, de pe care s-a îndepărtat folia de protecție pot fi curățate și folosite abia după 72 ore (timp pentru întărire ulterioară la aerul din încăpere).</p> <p>Nu deteriorați suprafețele cu obiecte ascuțite și în niciun caz nu le expuneți radiației solare puternice.</p> <p>E L I M I N A R E -Indicații privind eliminarea deșeurilor-</p> <p>De dragul mediului înconjurător, vă rugăm să eliminați deșeurile de ambalaj pe sortiment în tomberioanele de deșeurire/reciclare prevăzute în acest scop și nu în natură. Piesele de mobilier deteriorate sau inutilizabile pot fi predate la centre de reciclare speciale în scopul reciclării pieselor individuale.</p> <p>Piesele de mobilier scoase din uz, dar încă funcționale nu trebuie eliminate imediat. Donați-le, de exemplu, la organizații caritabile.</p> <p>Sperăm să vă bucurați de noul dumneastra mobilier.</p>

RU	SK	SL	SV
<p>Уважаемые покупатели! Благодарим вас за приобретение мебели из ассортимента наших изделий для внутренних помещений, предназначенной для использования исключительно в помещениях личного пользования. Пожалуйста, проверьте перед сборкой комплектность поставки и внимательно прочитайте приведенную далее важную информацию, а также сохраните ее для использования в будущем, в том числе, третьими лицами. Наши предметы мебели следует использовать в соответствии с их назначением. Ненадлежащее использование может причинить материальный ущерб, а при определенных обстоятельствах – привести к травмам. Предметы мебели – это не детские игрушки. Изготовитель и продавец не несут ответственности за ущерб, возникший в результате ненадлежащего применения или неправильного использования.</p> <p><b>ВНИМАНИЕ:</b> Дети и лица с задержкой умственного развития всегда должны находиться на определенном расстоянии от мебельных деталей, острых предметов и упаковочных материалов, поскольку существует опасность травмирования и риск удара.</p> <p><b>СБОРКА:</b> При сборке, пожалуйста, руководствуйтесь нашими инструкциями по эксплуатации, уходу, сборке или монтажу и обращайтесь особое внимание на предупредительные указания и указания по технике безопасности. Несоблюдение указаний может привести к травмам людей или повреждению мебели и представлять собой угрозу безопасности. Если у вас возникли сложности при сборке/монтаже, свяжитесь с нашей службой поддержки. Она окажет вам помощь словом и делом. Сборка должна осуществляться только квалифицированными лицами. При внесении изменений в изделие и его части, при замене деталей и расходных материалов и использовании при этом изделий не от производителя или официального дилера ответственность за повреждения и материальный ущерб исключается. Если к товару прилагаются средства для крепления на стену, например, дюбели или болты, они предназначены для использования только в стенах из однородных и монолитных материалов. Качество крепежа соответствует качеству соединения крепежного материала со стеной. Пожалуйста, проверьте перед креплением как стоящих, так и висятых предметов мебели свою стеноу на ее соответствие предъявляемым требованиям и используйте для этого только подходящие крепежные материалы. Перед возможной необходимостью сверления убедитесь, что в зоне сверления отсутствуют провода и иные коммуникации. В конечном счете, ответственность за крепление на стене несет сборщик и установщик мебели. Это также касается монтажа электрических деталей и других технологических комплектов. Монтаж и подключение электрических деталей и других технологических комплектов должны осуществляться только уполномоченными на это специалистами. Все электрические, а также технологические монтажные работы и работы по подключению должны проводиться в соответствии с действующими требованиями и правилами техники безопасности в вашей федеральной земле. В источниках света, пожалуйста, используйте только лампы допустимой мощности. При несоблюдении максимальной допустимой мощности в ваттах существует опасность пожара из-за перегрева. Не следует закрывать источники света из-за опасности возникновения пожара. Исправность мебели гарантируется только при ее установке с помощью отвеса и уровня. Двери предварительно отрегулированы, но может потребоваться их новая или дополнительная регулировка из-за условий на месте. Пожалуйста, обязательно соблюдайте данные по весу, касающиеся максимальной нагрузки. Запрещается взбираться на мебель. При ненадлежащем использовании может произойти опрокидывание предметов мебели. Чтобы избежать этого, необходимо всегда предохранять мебель от опрокидывания. При чрезмерном воздействии и нагрузках (в частности, играющими детьми, людьми, материалами или иным ненадлежащим образом) существует опасность поломки мебели и получения травм. Для обеспечения продолжительной устойчивости мебели все болты, а также опорные места соединений необходимо дополнительно подтянуть через 5-6 недель.</p> <p><b>УХОД:</b> Указания по уходу за мебелью. Пожалуйста, соблюдайте наши указания по правильному уходу за мебелью, чтобы наши изделия радовали вас как можно дольше. Для очистки используйте чистую, сухую и мягкую хлопчатобумажную ткань. Если вашей мебели нужна основательная очистка, вы можете нанести на ткань немного воды или средства для чистки мебели, а затем вытереть очищенные элементы насухо. Элементы из металла и стекла лучше всего чистить обычными средствами для чистки металла и стекла согласно имеющимся на них инструкциям по уходу. На чистящем средстве должно быть четко указано, что оно подходит для ухода за мебелью. Ни в коем случае не пользуйтесь парочистителями, едкими, абразивными и иными средствами, воздействие которых вам не известно.</p> <p><b>ВНИМАНИЕ:</b> Блестящие поверхности при поставке покрыты защитной пленкой. Не снимайте ее с мебели до тех пор, пока она не будет полностью собрана, установлена и очищена от пыли. Блестящие элементы, с которых была снята защитная пленка, можно чистить и использовать только спустя 72 часа (время отверждения на воздухе). Исключите повреждение поверхностей острыми предметами и ни в коем случае не подвергайте их воздействию сильного солнечного света.</p> <p><b>УТИЛИЗАЦИЯ:</b> Указания по утилизации отходов. Заботясь об окружающей среде, пожалуйста, утилизируйте упаковочный материал отдельно, помогая его в специальные баки для мусора с возможностью вторичной переработки.</p> <p>Поврежденную и непригодную к использованию мебель можно сдать в специальные пункты переработки материалов. Не следует сразу же подвергать утилизации отслужившую свой срок, но еще находящуюся в хорошем состоянии мебель. Передайте ее в дар, например, благотворительным организациям.</p> <p>Желаем вам много радости с вашей новой мебелью.</p>	<p>Vážená zákazníčka, vážený zákazník, ďakujeme, že ste si zakúpili nábytok z nášho interiérového programu na výhradné použitie v súkromných priestoroch. Skontrolujte úplnosť rozsahu dodávky a pred montážou si pozorne prečítajte nasledujúce dôležité informácie a uschovajte ich pre neskoršie využitie/použitie, a to aj tretími osobami.</p> <p>Nás nábytok sa musí používať podľa predpisov. Používanie v rozpore s predpismi môže viesť k vecným škodám a za istých okolností aj k zraneniam osôb. Nábytok nie je hračka. Za škody, ktoré vzniknú používaním proti predpisom alebo nesprávnou manipuláciou, nepreberá výrobca alebo predajca žiadnu zárukú.</p> <p><b>P O Z O R:</b> Deti alebo osoby s mentálnym postihnutím sa musia neustále držať mimo častí nábytku, špicatých predmetov, drobných častí a obalových materiálov, pretože hrozí riziko zranenia a/alebo udusenía.</p> <p><b>M O N T A Ž:</b> Pri montáži dodržiavajte náš návod na používanie, obsluhu, inštaláciu alebo montáž a dávajte hlavne pozor na výstražné a bezpečnostné pokyny. Pokiaľ sa nebudú dodržiavať predpisy, môže to mať za následok zranenie osôb alebo poškodenie nábytku/ohrozenie bezpečnosti. Ak by ste mali problémy s inštaláciou/montážou, kontaktujte náš servisný tím. Ochoťme vám poradiť a pomôcť. Montáž smie vykonávať iba kvalifikovaný personál. Pri zmenách na produkte/dieloch produktu, pri výmene alebo použití dielov/spotrebných materiálov, ktoré nepočádzajú od výrobcu/predajcu, nepreberáme žiadnu zodpovednosť za škody.</p> <p>Pokiaľ sú k tovaru priložené úpevňovacie prvky na stenu, ako sú hmoždinky a skrutky, sú tieto určené výhradne na použitie na stenách z pevných a jednoliatych materiálov. Upevnenie je len tak dobré, ako dobré je spojenie medzi úpevňovacím prostriedkom a stenou. Pred upevnením musíte skontrolovať vhodnosť vašej steny pre stojaci aj závesný nábytok a použiť iba vhodné spojovacie prvky. Pred prípadným vŕtaním sa uisťte, že sa v oblasti vŕtania nenachádzajú elektrické vodiče. Nakoniec je za upevnenie na stenu zodpovedný inštaláčný technik.</p> <p>Platí to aj pre inštaláciu elektrických produktov a ďalšieho stavebno-technického príslušenstva. Montáž/inštaláciu elektrických produktov a tiež ďalšieho dôležitého konštrukčného príslušenstva môže vykonávať iba autorizovaný kvalifikovaný personál. Všetky elektrické a stavebno-technické inštalácie musia byť vykonané v súlade s platnými normami a bezpečnostnými predpismi vo vašej krajine. Pre svetelné zdroje používajte iba povolenú intenzitu osvetlenia. Pri nedodržaní max. počtu Watt hrozí riziko požiaru v dôsledku prehriatia. Prekrývanie svetiel nie je povolené z dôvodu rizika požiaru.</p> <p>Dokonale funkcia nábytku je záručená iba pri vertikálnej a horizontálnej inštalácii. Dvere sú vopred nastavené, môžu sa ale znova nastaviť na základe miestnych podmienok. Dodržiavajte údaje o hmotnosti pre maximálne zaťaženie. Na nábytok sa nesmie liezť. Pri neodbornom použití môže dôjsť k prevráteniu nábytku. Aby sa tomu zabránilo, musí byť nábytok neustále zaistený proti prevráteniu. Pri preťažení/nadmernom preťažení (najmä hrájúcimi sa deťmi, ľuďmi, materiálom alebo inými nevhodnými vplyvmi) hrozí riziko rozbitia a zranenia. Všetky skrutky a nosné spojovacie miesta by mali byť dotiahnuté po 5 až 6 týždňoch, aby sa zaisťala trvalá stabilita.</p>	<p>Spóštovana stranka, zahvaljujemo se vam za nakup pohištva iz našega programa za notranje ureditve za izključno uporabo v zasebnih prostorih. Prosimo, da preverite popolnost obsega dobave in pred montažo pozorno preberete naslednje pomembne informacije ter jih shranite za poznejšo uporabo, tudi s strani tretjih oseb.</p> <p>Naše kose pohištva morate uporabljati skladno z njihovim namenom. Nepravilna uporaba lahko povzroči materialno škodo ali celo poškoduje ljudi. Pohištvo ni igrača. Proizvajalec ali trgovec ne prevzema odgovornosti za škodo, ki nastanejo zaradi nepravilne uporabe ali napačnega ravnanja.</p> <p><b>P O Z O R:</b> Otroci ali osebe z motnjami v duševnem razvoju se nikoli ne smejo približati delom pohištva, koničastim predmetom, malim delom in embalažnim materialom, saj obstaja nevarnost telesnih poškodb in/ali zadržitve.</p> <p><b>M O N T A Ž A:</b> Pri montaži se ravnajte skladno z našimi navodili za uporabo, upravljanje, nameščanje ali montažo ter zlasti upoštevajte opozorila in varnostne napotke. Če ne upoštevate navodil, lahko to povzroči telesne poškodbe oseb ali škodo na pohištvu/varnostno tveganje. Če imate težave pri sestavljanju/montaži, se obrnite na našo servisno ekipo. Pomagali vam bodo z nasveti in dejanji. Montažo smejo izvajati samo strokovno usposobljene osebe. Pri spremembah na izdelku/delih izdelka, zamenjavi ož. uporabi delov/potrošnega materiala, ki jih ne zagotavlja proizvajalec/trgovec, ni mogoče prevzeti odgovornosti za škodo.</p> <p>Če so izdelku priložena sredstva za pritrditev na steno, kot so sidni vložki in vijaki, so namenjena izključno za uporabo na stenah iz masivnih in enoliatih materialov. Pritrditev je samo tako dobra, kot je povezava med sredstvi za pritrdjevanje in steno. Pri stoječem in visečem pohištvu pred pritrditvijo preverite steno, ali je primerna, in uporabite izključno tisto za primerna sredstva za pritrdjevanje. Pri morebitnim vrtanjem se prepričajte, ali v območju vrtanja ni napeljav. Izključno monter je odgovoren za pritrditev na steno.</p> <p>To vključuje tudi namestitve električnih izdelkov in drugih tehničnih sestavnih delov. Montažo/namestitve električnih izdelkov in druge zedevne dodatne opreme smejo izvajati samo pooblašteni strokovnjaki. Vse električne in gradbenotehnične namestitve je treba izvesti skladno z veljavnimi standardi ož. varnostnimi predpisi v vaši državi. Pri virih svetlobe uporabljajte samo dovoljene jakosti sijalk. Pri neupoštevanju največje moči v vatih obstaja nevarnost požara zaradi pregretja. Pokrivanje sijalk je zaradi nevarnosti požara prepovedano.</p> <p>Brezhibna funkcija pohištva je zagotovljena samo pri navpični in vodoravni postavitvi. Vrata so predhodno naravnana, vendar jih je treba zaradi krajevnih okoliščin znova poravnati/nastaviti. Pri navedbah mase obvezno upoštevajte največje obremenitve. Pohištvo ni dovoljeno pritrditi. Pri nepravilni uporabi lahko pride do prevrnitve koso pohištva. Da boste to preprečili, mora biti pohištvo vedno zavarovano pred prevrnitvijo. Pri preobremenitvah (zlasti med igr o otrok, zaradi ljudi, materiala ali drugih nepravilnih učinkov) obstaja nevarnost zloma in telesnih poškodb. Vse vijake in nosilna spojna mesta je treba po 5 do 6 tednih znova zategniti, da zagotovite trajno stabilnost.</p> <p><b>N E G A:</b> -Napotki za nego pohištva- Upoštevajte naše napotke glede pravilne nege pohištva, da boste lahko čim dlje uživali z našim izdelkom. Pri čiščenju uporabljajte čisto, suho in mehko bombažno krpo. Če je treba vaše pohištvo temeljito očistiti, lahko krpo navlažite z malo vode ali sredstva za čiščenje pohištva, nato pa morate očiščne dele posušiti. Kovinske in steklene delse boste najbolje očistili z običajnimi čistili za kovino in steklo skladno z na njih navedenimi navodili za nego. Na sredstvih za čiščenje mora biti jasne navedeno, da so primerna za nego pohištva. Nikakor ne uporabljajte pernega čistilnika ali jedkih, abrazivnih in drugih sredstev, katerih delovanja ne poznate.</p> <p><b>P O Z O R:</b> Visokosijajne površine so pri dobavi zaščitene s folijo. Pustite jo na pohištvu, dokler ni povsem namočeno, ter ga tako zaščitite pred prahom. Visokosijajni elementi, s katerih je bila odstranjena zaščitna folija, se smejo šele po 72 urah (čas do strditve na zraku v prostoru) očistiti in uporabljati.</p> <p>Površin ne smete poškodovati z ostrimi predmeti in jih nikakor ne izpostavljajte močnim sončnim žarkom.</p>	<p>Kära kund, vi tackar dig för köpet av en möbel i vårt inomhusprogram, som är avsedd uteslutande för användning i privata utrymmen. Kontrollera leveransomfånget med avseende på fullständighet. Läs igenom nedanstående viktiga information noga före monteringen och spara den för ditt eget och tredje parts senare bruk.</p> <p>Våra möbler ska användas för det avsedda ändamålet. Om de används för andra ändamål än det avsedda, kan det leda till sakskador eller under vissa omständigheter till personskador. Möbler är inga leksaker för barn. För skador som uppkommer till följd av icke avsedd användning eller felaktig hantering, påtar sig tillverkaren eller återförsäljaren inget ansvar.</p> <p><b>O B S:</b> Barn eller personer med mental funktionsnedsättning ska alltid hållas borta från möbeldelar, vassa föremål, smådelar och förpackningsmaterial. Det finns risk för personskador och/eller kvävning.</p> <p><b>M O N T E R I N G:</b> Följ våra bruks-, installations- eller monteringsanvisningar vid monteringen, och var särskilt noga med att följa varningar och säkerhetsanvisningar. Om anvisningarna inte följs, kan det leda till personskador eller skador på möbelen/orsaka en säkerhetsrisk. Om du har problem med uppbyggnaden/monteringen, ska du kontakta vårt serviceteam. Det hjälper dig med råd och råd. Monteringen får utföras endast av yrkeskunniga personer. Om det görs ändringar på produkten/delar av produkten eller om det används delar/förbrukningsmaterial som inte kommer från tillverkaren/återförsäljaren, kan inget ansvar tas för skador.</p> <p>Om material för fästsättning på väggen, som pluggar och skruvar, medföljer produkten, är detta avsett att användas endast på väggar som består av massivt och enhetligt material. En fästsättning är bara så bra som förbindelsen mellan fästsättningsmaterialet och väggen. Både när det gäller stående och hängande möbler ska du kontrollera om din vägg lämpar sig för ändamålet innan du sätter fast dem, och använd endast lämpligt fästsättningsmaterial. Innan du borrar, ska du förvissa dig om att det inte ligger några ledningar i det område där du tänker borra. Slutligen är montören ansvarig för fästsättningen på väggen. Detta gäller också för installation av elektriska produkter och andra byggtkniska tillbehörskomponenter. Elektriska produkter och annat byggrelaterat tillbehör får monteras/installeras endast av behörig fackpersonal. Alla elektriska och byggtkniska installationer ska genomföras enligt de normer resp. säkerhetsföreskrifter som gäller i ditt län. Använd endast tillåtna lampstyrkor för ljuskällor. Om det maximala wattalet överskrids, finns brandrisk på grund av överhettning. På grund av brandrisk får lamporna inte täckas över.</p> <p>Möbels felfria funktion är garanterad endast vid lod- och vågrät uppställning. Dörrarna är förjusterade, men måste eventuellt riktas/justeras på nytt beroende på de lokala förhållandena. Var noga med att följa viktangivelserna för maximal belastning. Det är förbjudet att stiga upp på möbler. Vid olämplig användning finns risk för att möbler välter omkull. För att förebygga detta, bör möbler alltid säkras mot tipping. Vid överlast/överbelastning (särskilt på grund av lekande barn, människor, material eller annan olämplig påverkan) finns risk för brott och personskador. Alla skruvar och bärande förbindningsställen ska dras åt en gång till efter 5 till 6 veckor, för att säkerställa en varaktig stabilitet.</p> <p><b>S K Ö T S E L:</b> -Kötselråd för möbler - För att du ska ha glädje av vår produkt under så lång tid som möjligt, ska du följa våra kötselråd för rätt kötsel av möbler.</p> <p>Använd en ren, torr och mjuk bomullstrasa för rengöring. Om dina möbler behöver en grundlig rengöring, kan du fuktig trasan med lite vatten eller rengöringsmedel för möbler och sedan torka de rengjorda delarna. Metall- och glasdelar ska du helst rengöra med vanlig rengöringsmedel för metall och glas enligt de kötselråd som står på förpackningen. Det måste vara tydligt angett på dessa rengöringsmedel att de är lämpliga för kötsel av möbler.</p> <p>Använd inte under några omständigheter ångrengöringsapparater eller frätande, skurande eller andra medel vars effekt du inte känner till.</p> <p><b>O B S:</b> Glänsande ytor är vid leverans skyddade med en skyddsfolie. Låt denna vara kvar på möbelen tills den har monterats helt och hållet och befriats från damm. Glänsande delar som skyddsfolien har avlägsnats från, får inte rengöras och användas förrän 72 timmar senare (tid för efterhärdning i rumsluft).</p> <p>Skada inte ytor med vassa föremål, och var noga med att inte utsätta dem för alltför starkt skölj.</p>
	<p><b>STAROSTLIVOSŤ:</b> - Pokyny pre starostlivosť o nábytok - Dodržiavajte naše pokyny pre správu starostlivosť o nábytok, aby ste si náš výrobok mohli užívať čo najdlhšie. Pri čistení používajte čistú, suchú a mäkkú bavlnenú handričku. Pokiaľ potrebujete váš nábytok dôkladné vyčistenie, môžete handričku navlhčiť trochou vody alebo čistiaceho prostriedku na nábytok a potom vyčistené diely vysušíť. Kovové a sklenné diely sa najlepšie čistia bežne dostupnými čistiacimi prostriedkami na kov a sklo podľa pokynov uvedených na výrobku. Na čistiaciach prostriedkoch musí byť jasne uvedené, že sú vhodné na čistenie nábytku. V žiadnom prípade nepoužívajte parné čističe, žieraviny, abraziva alebo iné prostriedky, ktorých účinky nepoznáte.</p> <p><b>P O Z O R:</b> Vysoko lesklé povrchy sú pri dodávke chránené ochrannou fóliou. Nechajte fóliu na nábytku, kým nebude úplne zmontovaný a zbavený prachu. Vysoko lesklé prvky, z ktorých bola odstránená ochranná fólia, je možné čistiť a používať až po 72 hodinách (doba pre následné vytvrdnutie na okolitom vzduchu).</p> <p>Povrchy nemožno poškodiť ostrými predmetmi a nikdy ich nemôžete vystavovať silnému slnečnému žiareniu.</p>	<p><b>ODLAGANJE MED ODPADKE</b> -Napotki za odlaganje med odpadke- Zaradi varstva okolja zavrzite odpadno embalažo skladno z vrsto embalaže v za to predvidene zabojnike za odpadke/reciklažo in ne v naravo. Poškodovano ali neuporabno pohištvo lahko odpeljete v specializirana zbirališča za reciklažo posameznih delov. Odslužnega, vendar še uporabnega pohištva ni treba takoj zavreči. Lahko ga oddate npr. dobrodelnim organizacijam.</p> <p>Želimo vam veliko veselja z vašim novim pohištvom.</p>	
	<p><b>L I K V I D Á C I A</b> - Pokyny na likvidáciu odpadu - V záujme ochrany životného prostredia vyhadzujte obalový odpad roztriedený podľa druhu do určených odpadkových/recyklačných nádob, v žiadnom prípade nevyhadzujte do prírody. Poškodené alebo nepoužívané nábytok je možné odoslať do špeciálnych zberných zariadení na recykliáciu jednotlivých dielov. Použitý, ale stále funkčný nábytok nie je nutné hned likvidovať. Darujte ho napr. charitatívnym organizáciám.</p> <p>Prajeme vám veľa zábavy s vašim novým nábytkom.</p>		

Değerli müşterimiz, evde kullanım için tasarlanan iç mekan programımızdan bir mobilya satın aldığınız için teşekkür ederiz. Lütfen teslimat kapsamının eksiksiz olup olmadığını kontrol edin ve montajdan önce aşağıdaki önemli bilgileri dikkatlice okuyun ve daha sonra üçüncü şahıslar tarafından da kullanılmak üzere saklayın.

Mobilyalarımız amaçlandığı şekilde kullanılmalıdır. Amacı dışında kullanım, maddi hasarlara veya bazı durumlarda kişisel yaralanmalara neden olabilir. Mobilyalar çocuk oyuncakları değildir. Üretici veya satıcı, amacı dışında veya yanlış kullanımdan kaynaklanan hasarlar için hiçbir sorumluluk kabul etmez.

**D İ K K A T:** Çocuklar veya zihinsel engelli kişiler, yaralanma ve/veya bozulma riski bulunduğundan, mobilya parçalarından, sürtüme nesnelere, küçük parçalardan ve ambalaj malzemelerinden daima uzak tutulmalıdır.

**M O N T A J:** Montaj sırasında lütfen işlemleri, kullanım, kurulum veya montaj talimatlarınıza uyun ve uyan ve güvenlik talimatlarına özellikle dikkat edin. Talimatlara uyulmaması, kişisel yaralanmaya veya mobilya hasarına/güvenlik riskine neden olabilir.

Montaj / kurulum konusunda zorluk yaşıyorsanız, lütfen servis ekibimize iletişime geçin. Ekibimiz tavsiyelerle ve destekleriyle size yardımcı olacaktır. Montaj sadece uzman kişiler tarafından yapılmalıdır.

Ürün/ürün parçalarında değişiklikler, üreticiden/satıcıdan gelmeyen parçalarla/sarf malzemeleriyle değiştirilmesi veya kullanılması durumunda meydana gelebilecek hasarlar için sorumluluk kabul edilmez.

Ürünlere dübel ve vida gibi duvara sabitleme araçları eklenmişse, bunlar sadece sağlam ve tek tip malzemelerin yapılmış duvarlarda kullanılmak üzere tasarlanmıştır. Bir bağlantı sadece bağlantı elemanı ve duvar arasındaki bağlantı kadar iyidir. Lütfen mobilyayı sabitlemeden önce duvarınızın hem ayakta hem de asılı mobilya için uygunluğunu kontrol edin ve sadece uygun bağlantı elemanları kullanın. Olası bir delme işleminden önce delme alanında tesisat olmadığından emin olun. Sonuçta, montajı yapan kişi duvara sabitlemekten sorumludur.

Bu aynı zamanda elektrikli parçaların ve diğer yapısal aksesuarların montajı için de geçerlidir. Elektrikli parçaların ve diğer inşaatla ilgili aksesuarların montajı/kurulumu sadece yetkili uzman personel tarafından yapılabilir. Tüm elektrik ve yapısal kurulumlar, eyaletinizdeki geçerli standartlara ve güvenlik yönetmeliklerine uygun olarak yapılmalıdır.

Işık kaynakları için lütfen sadece izin verilen aydınlatma güçlerini kullanın. Maksimum Watt değerine uyulmaması durumunda aşırı ısınma nedeniyle yangın riski söz konusudur. Yangın tehlikesi nedeniyle aydınlatmaların üstünü kapatmak yasaktır.

Mobilyaların düzgün fonksiyonu sadece düz ve yatay zeminde garanti edilir. Kapılar önceden ayarlanmıştır, ancak yerel koşullar nedeniyle yeniden hizalanması/ayarlanması gerekebilir. Lütfen maksimum yük ile ilgili ayrıntı bilgilerine uyun. Mobilyaların üzerine çıkılması yasaktır. Yanlış kullanım mobilyaların devrilmesine neden olabilir.

Bunu önlemek için mobilyalar her zaman devrilmeye karşı emniyete alınmalıdır. Aşırı yük/aşırı zorlama durumunda (özellikle oyun oynayan çocuklar, insanlar, malzeme veya diğer uygunsuz etkiler nedeniyle) kırılma ve yaralanma riski söz konusudur. Kalıcı sağlamlığı güvenceye almak için tüm duvarlar ve yük taşıyan bağlantı noktaları 5-6 hafta sonra tekrar kontrol edilmelidir.

**B A K I M:**  
-Mobilya bakımına ilişkin notlar-  
Ürününüzün keyfini olabildiğince uzun süre çıkarabilmeniz için lütfen uygun mobilya bakımıyla ilgili talimatlarımızı dikkatle alın.

Temizlik sırasında temiz, kuru ve yumuşak pamuklu bir bez kullanın. Mobilyanızın kapsamlı bir temizliği ihtiyacı varsa, bezi biraz su veya mobilya temizleyicisiyle nemlendirilebilir ve ardından temizlenen eşyaları kurutabilirsiniz. Metal ve cam parçaları, üzerindeki bakım talimatlarına göre piyasada bulunan metal ve cam temizleyicilerle en iyi şekilde temizleyebilirsiniz. Temizlik maddeleri, mobilya temizliği için uygun olduklarının açık bir göstergesini taşımamalıdır.

Hiçbir koşulda buharlı temizleyiciler, kostik, aşındırıcı veya etkilere aşına olmadığınız diğer maddeleri kullanmamalısınız.

**D İ K K A T:** Çok parlak yüzeyler teslimat sırasında koruyucu bir folyoyla korunur. Bunu tamamen monte edilene ve tozu temizlenene kadar mobilya üzerinde bırakın. Koruyucu folyonun çıkarıldığında çok parlak elemanlar ancak 72 saat sonra temizlenebilir ve kullanılabilir (ortam havasında son katlaşma süresi). Yüzeylere keskin nesnelere zarar vermeyin ve asla güçlü güneş ışığına maruz bırakmayın.

**T A S F İ Y E**  
-Tasfiyeyle ilgili notlar-  
Çevre için lütfen türüne göre ayrılmış ambalaj atıklarını doğaya değil, bunlar için sağlanan atık/geri dönüşüm kutularında tasfiye edin.

Hasarlı veya kullanılmayan mobilyalar, her bir parçanın geri dönüştürülmesi için özel geri kazanım tesislerine gönderilebilir.

Artık kullanılmayan ancak hala işlevsel olan mobilyalarınızı hemen tasfiye edilmesi gerekmektedir. Bunları örneğin hayır kurumlarına bağışlayın.

Yeni mobilyalarınızı güle güle kullanın.

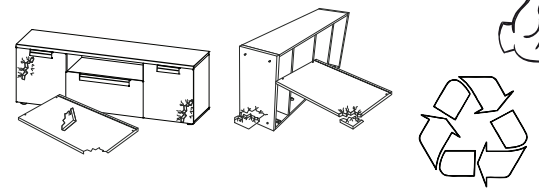
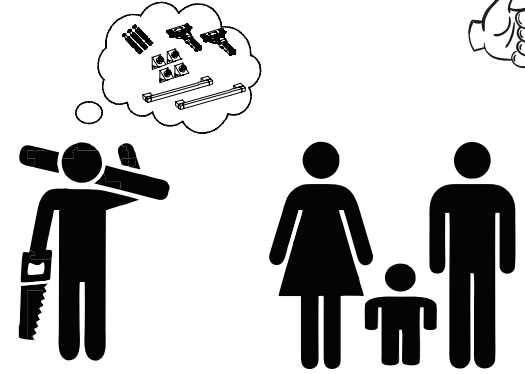
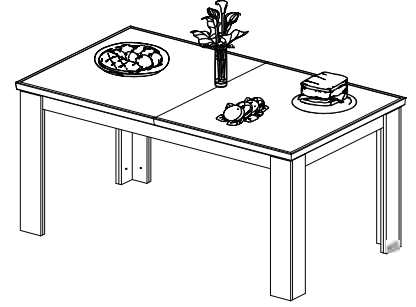
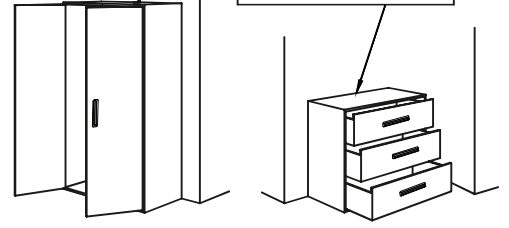
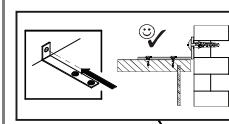
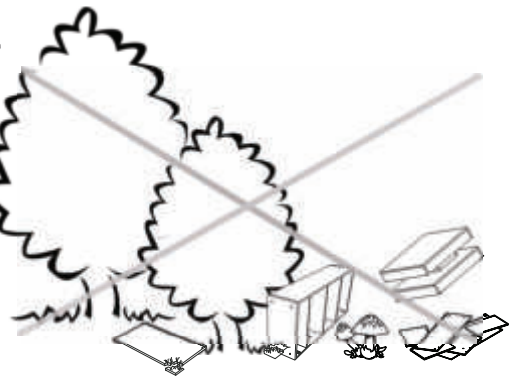
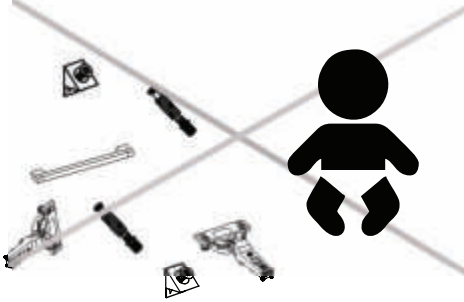
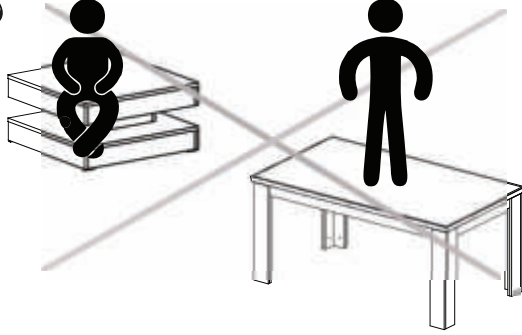
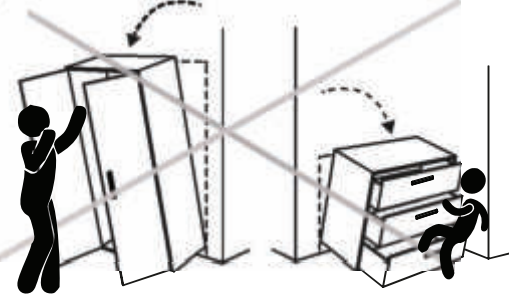

LKZ 80236

Modellname / Model name / Nom du modèle / Modellnamn / Nome modello / Název modelu / Modelnaam / Ime modela / Numéro Modelo / Modell neve / Название модели / Názov modelu / Ime modela / Denumire model / Наименование на модела / Nazwa modelu

**SynnaX**

Modellnummer / Number / Numéro du modèle / Numero / Номер на модела / modello / Číslo modelu / Modell száma / Ěíslo modelu / Številka modela / Număr model / Broj modela / Modelnummer / Numer modelu

**2134-117-84**

Type / Tipo / Tipus / Typ / Тип / Tip

**117**

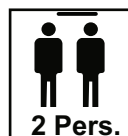
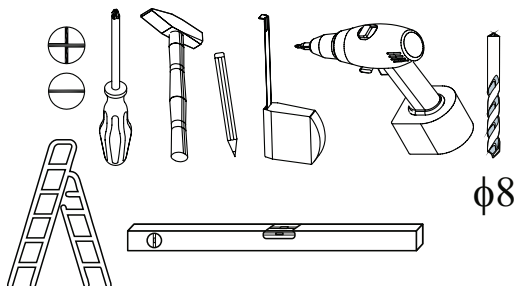
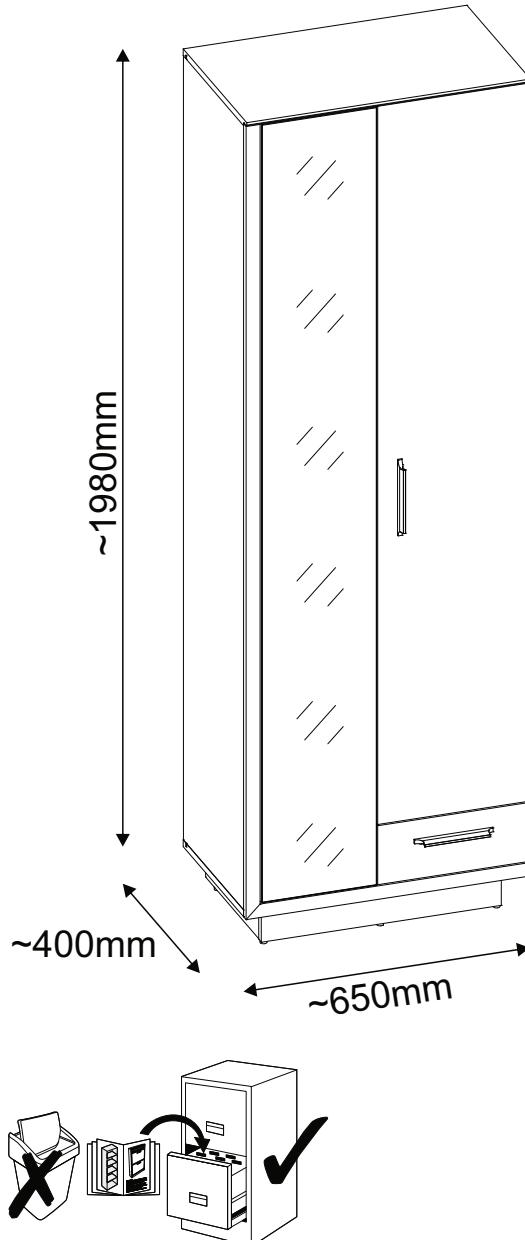
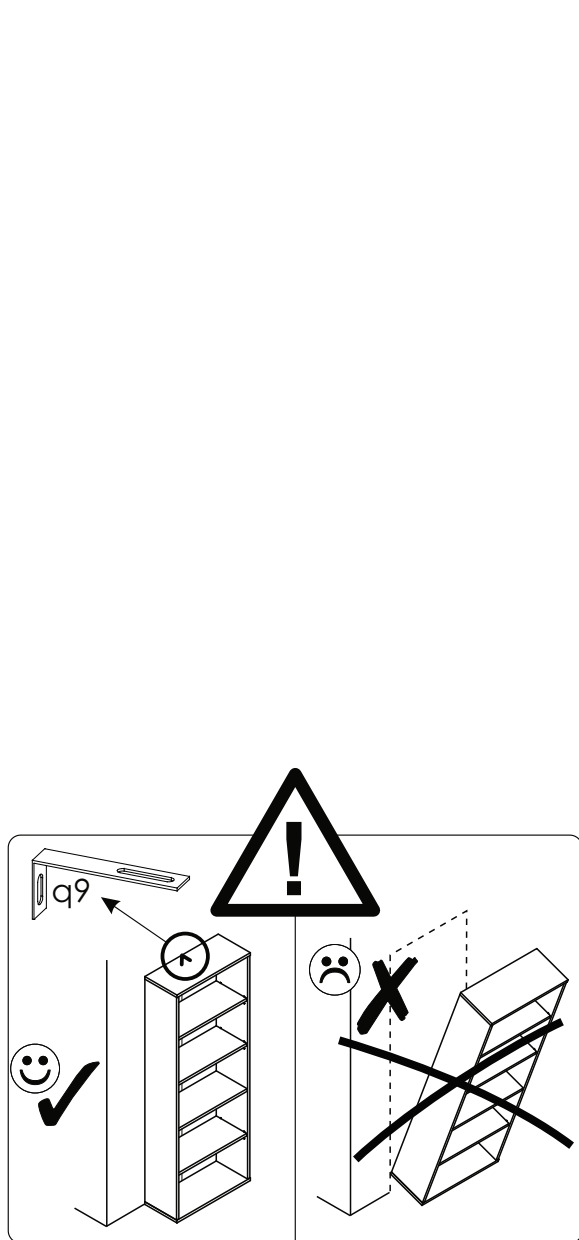
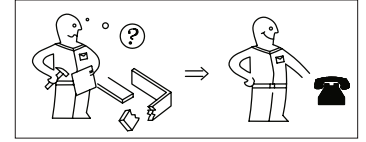
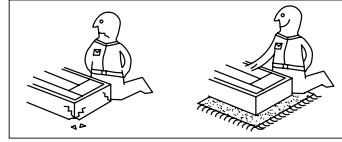
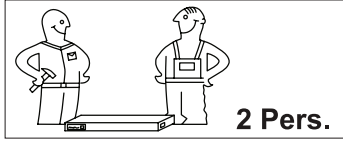

festziehen / tighten / Затягнете / serrer / stringere / utáhnout / vasttrekken / zategnuti / strängere / związac / zacisnac / szorosan meghúzni / pevne dotiahnut / trdno pritegniti / затянуть / dra át

eindrücken / press in / enfoncer / wcisnąć / ribattere / zatlačit / Вкарайте / indrukken / benyomni / sítacit / vtisniti / tryck in / introducere prin apăsare / вдвигать

ausmessen / measure / mesurer / misurare / opmeten / izmeriti / miara / kimérni / izmeriti / măsurare / измерить / změřit / Измерете / mät upp / zmierzyc



drücken / press / presser / stisknout / Натиснете / vtisniti / nasinac / drukken / pritisnuti / nacsinac / pritisniti / нажать / (meg)nyomni / apăsare / tryck fast / nacsinac

einschlagen / hammer in / bevern / sla in / frapper au marteau / infossare / Zabit' / zarazit / Набийте / zabiti / wbić / introducere prin bătaie / забить / zatloct

Drehen - wenden / przekreć - odwrócić / Keren - omdraaien / Girare - Ruotare / Okrenuti - ubrnuti / Retourner - renverser / Turn over - turn around / Otočte - obratite / Zавъртете - обърнете / Obrnite list / Întoarceți - rotiți / Vrid runt - vänd / прокрутить - повернуть / otočit - obrátit / elforgatni - megfordítani

LKZ 80236

Modellname / Model name / Nom du modèle / Modellnamn  
Nome modello / Název modelu / Modelnaam / Ime modela  
Número Modelo / Modell neve / Название модели /  
Názov modelu / Ime modela / Denumire model /  
Наименование на модела / Nazwa modelu

**Synnax**

Modellnummer / Number / Numéro du modèle  
Numero / Номер на модела / modello  
Číslo modelu / Modell száma / Éíslo modelu  
Številka modela / Număr model / Broj modela  
Modelnummer / Numer modelu

2134-117-84

Type / Tipo / Tipus / Typ / Тип / Tip

**117**

**D** Unser Direktservice für Beschlagteile  
Sollte Ihnen ein Beschlagteil fehlen, können Sie diese Servicekarte  
direkt an die untenstehende Adresse mailen. Wir können allerdings  
nur Beschlagteile auf diesem Wege verschicken. Sollten Sie eine  
andere Beanstandung an Ihrem Möbelstück haben, so wenden Sie  
sich bitte direkt an Ihr Möbelhaus.

**GB** Our direct order service for fitting  
If a fitting part is missing, you can e-mail this service card directly  
to the address below. However, we can only send fitting parts in  
this way. If you have any other cause for complaint concerning  
your item of furniture, please contact your furniture store directly.

**CZ** Naše přímé služby pro kování  
Chybí-li vám nějaký díl z kování, můžete tuto servisní kartu odeslat  
e-mailem přímo na níže uvedenou adresu. Touto cestou však  
můžeme rozestlat jen díly kování. Pokud byste reklamovali jiný díl  
nábytku, obraťte se přímo na svého prodejce nábytku.

**F** Bien étudier la notice de montage  
S'il vous manque une ferrure, veuillez envoyer directement la présente  
carte service à l'adresse e-mail indiquée ci-dessous. Cependant, ceci  
nous permet uniquement d'envoyer des ferrures. Pour tout autre type  
de réclamation concernant votre meuble, veuillez contacter  
directement votre magasin d'ameublement.

**I** Il nostro servizio diretto per l'ordine della ferramenta  
Qualora Vi dovesse mancare un pezzo di fissaggio, allora Vi  
preghiamo di inviare questa carta di servizio immediatamente  
all'indirizzo sottostante. Possiamo inviare i pezzi di fissaggio  
solamente per mezzo di questo procedimento. Qualora dovreste  
avere qualche altra reclamazione in merito al mobile, allora Vi  
preghiamo di rivolgerVi direttamente al Vostro Negozio di mobili.

**BG** Нашата директна услуга за обков  
Ако липсват части от комплекта, потърнете настоящата  
сервисна карта и ни я изпратете на e-mail адреса, посочен  
по-долу. По този начин можем да доставяме само липсващи  
елементи от обкова. Ако установите други дефекти по  
мебелите, Ви съветваме да се обърнете към мебелната  
къща/магазин, от който сте закупили стоката.

**NL** Onze directservice voor losse onderdelen  
Wanneer er een onderdeel ontbreekt, kunt u deze servicekaart  
direct aan onderstaand e-mailadres sturen. Wij kunnen langs deze  
weg echter alleen beslagdelen versturen. Mocht u een ander  
probleem aan uw meubel hebben, verzoekten wij u contact op te  
nemen met uw meubeldealer.

**PL** Nasz bezpośredni serwis części montażowych  
Jeżeli brakuje części koniecznych do montażu, prosimy o przesłanie  
nam niniejszej karty serwisowej na niżej podany adres e-mailowy.  
W ten sposób możemy przesłać Państwu tylko brakujące części.  
W przypadku innych reklamacji dotyczących mebla, prosimy zgłosić  
się do salonu meblowego, w którym został dokonany zakup.

**HR** Servis za okove  
U slučaju da nedostaje neki od dijelova molimo vas da na dolje  
navedenu mail adresu pošaljete ovaj servisni obrazac. Na ovaj način  
mogu se dostaviti samo okovi. U slučaju da imate dodatne prigovore  
vezane uz komad namještaja molimo vas da se obratite izravno  
trgovini namještaja gdje je isti kupljen.

**HU** Direktzolgáltatunk vasalattok esetén  
Ha hiányzik egy vasalat, ezt a kártyát közvetlenül elküldheti az  
alább található címre. Azonban csakis vasalattokat tudunk így  
küldeni. Amennyiben másfajta reklamáció áll fenn bútordarabját  
illetően, forduljon közvetlenül a bútortházhoz.

**SK** Naš priamy servis pre časti kovania  
Ak by Vám chýbala nejaká časť kovania, môžete poslať  
túto servisnú kartu poslať e-mailom na nižšie uvedenú  
adresu. Diely kovania vieme poslať iba týmto spôsobom.  
Ak by ste mali inú reklamáciu ohľadom Vášho nábytku,  
obráťte sa priamo na Vašu predajňu nábytku.

**SLO** Naše direktno uslužne storitve za okovje  
Če vam manjka kakšno okovje, lahko to servisno kartico pošljete  
po e-pošti direktno na spodnji naslov. Po tej poti vam lahko  
pošljemo samo okovje. Če želite reklamirati kakšen drug del  
pohištva, se obrnite neposredno na vaše trgovino pohištva.

**RO** Service-ul nostru direct pentru feronerie  
În cazul în care vă lipsește o piesă de feronerie puteți să trimiteți  
direct acest card de service prin e-mail la adresa de mai jos. Noi  
nu putem expedia piese de feronerie decât pe această cale.  
Dacă aveți o altă reclamație referitoare la piesa de mobilier,  
atunci vă rugăm să vă adresați direct la magazinul dvs. de mobilă.

**RUS** Наш прямой сервис для поставок фурнитуры  
Если окажется, что Вам не хватает того или иного элемента  
фурнитуры, Вы можете отправить сервисную карту по факсу  
непосредственно на нижеприведенный адрес электронной  
почты. Однако, таким образом мы можем пересылать лишь  
фурнитуру. Если же у Вас возникнут иные претензии относительно  
приобретенной мебели, пожалуйста, обращайтесь  
непосредственно в организацию, осуществившую продажу.

**S** Vår direktservice för beslagsdelar  
Om du saknar en beslagsdel kan du skicka detta servicekort direkt  
till e-postadressen som anges nedan. Tänk på att detta är den enda  
möjligheten att skicka beslagsdelar till dig. Om du vill reklamera din  
möbel av en annan anledning måste du kontakta ditt möbelhus direkt.

**ES** Nuestro servicio directo para accesorios  
Si le falta algún accesorio, puede enviar esta tarjeta de servicio directamente  
a la siguiente dirección. No obstante, por este método solo podemos  
enviar accesorios. Si tiene alguna otra objeción sobre su mueble, consulte  
directamente con su mueblería.

**TR** Donatılar için doğrudan servisimiz  
Bir donatınız eksikse bu servis kartını doğrudan aşağıda bulunan adrese  
doğrudan mail yazabilirsiniz. Sadece bu yolla donatılar gönderilebilir.  
Mobilyanızda başka şikayetleriniz varsa lütfen doğrudan mobilya satıcınıza  
danışın.

1	650	400	16	x1	1/2
2	650	380	16	x1	1/2
3	1863	380	16	x1	2/2
4	1863	380	16	x1	2/2
5	617	360	16	x1	1/2
6	617	360	16	x1	1/2
7	153	360	16	x1	1/2
8	616	355	16	x1	1/2
9	550	80	16	x1	1/2
10	516	80	16	x1	1/2
11	337	80	16	x1	1/2
12	337	80	16	x1	1/2
13	1877	630	3	x1	2/2
14	1849	264	20	x1	2/2
15	1706	346	16	x1	2/2
16	346	140	16	x1	1/2
17	350	100	16	x1	1/2
18	350	100	16	x1	1/2
19	286	86	16	x1	1/2
20	298	355	3	x1	1/2
21	1884	32	16	x1	2/2
22	650	32	16	x1	2/2

max



max

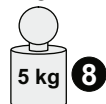

max

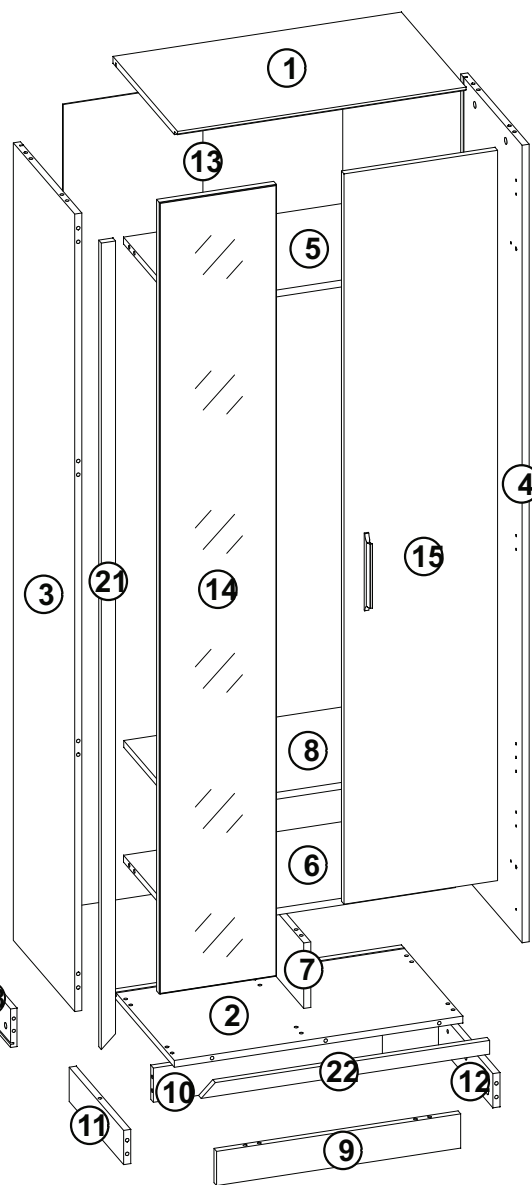

Grund der Beanstandung / Cause for complaint:

Möbelhaus / Furniture store:

Kunde / Customer:

Telefon / Telephone:

PLZ / Postcode:

Ort / City:

Str.+Nr. / Street address

@E-Mail:



LKZ 80236

Modellname / Model name / Nom du modèle / Modellnamn  
Nome modello / Název modelu / Modelnaam / Ime modela  
Numéro Modello / Modell neve / Название модели /  
Názov modelu / Ime modela / Denumire model /  
Наименование на модела / Nazwa modelu

**Synnax**











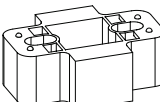
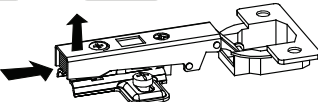
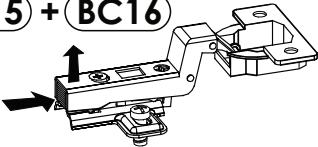

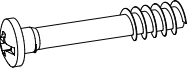

Modellnummer / Number / Numéro du modèle  
Numero / Номер на модела / modello  
Číslo modelu / Modell száma / Ěíslo modelu  
Številka modela / Număr model / Broj modela  
Modelnummer / Numer modelu

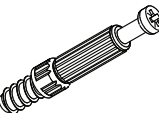
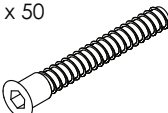
2134-117-84

Type / Tipo / Tipus / Typ / Тип / Tip

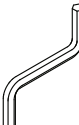

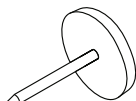
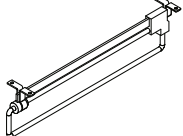
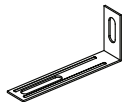
**117**

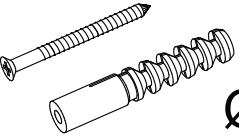
## B1 Colli 1/2

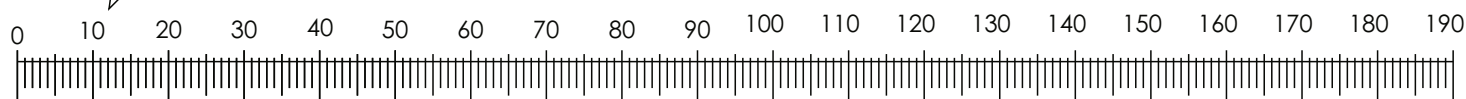
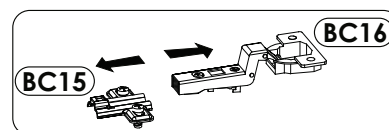
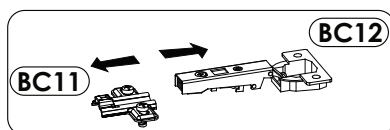
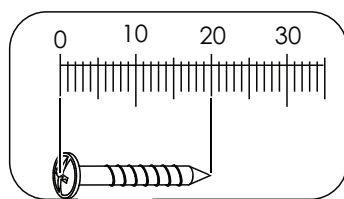
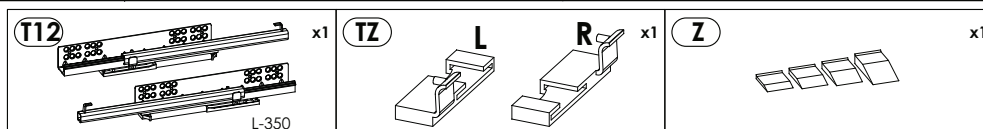
<b>A1</b> 8 x 35 x36 	<b>B4B</b>  x3	<b>BC11 + BC12</b>  x3
<b>BC15 + BC16</b>  x3	<b>C2</b> 5x13 x16 	<b>C12</b> 6,3 x 33 x6 
<b>D2</b>  x4	<b>E0</b>  x16	<b>E1</b> 15 x 12,5 x33 
<b>F1</b>  x33	<b>G1</b> 7 x 50 x8 	<b>H1</b> L-180 x2 
<b>I2</b> 4 x 16 x6 	<b>I5</b> 3,5 x 27 x4 	<b>M</b>  x1
<b>N1</b> 3 x 16 x15 	<b>O2</b>  x6	<b>P7</b>  x1
<b>Q9</b>  x2	<b>R4</b>  x15	<b>S13</b>  x2 Ø8

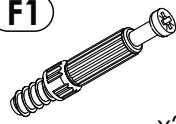

1

<b>A1</b> 8 x 35  x4	<b>E1</b> 15 x 12,5  x4	<b>F1</b>  x2
-------------------------------------------------------------------------------------------------------------	----------------------------------------------------------------------------------------------------------------	-----------------------------------------------------------------------------------------------------

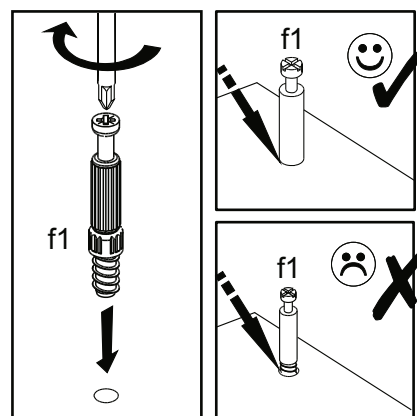
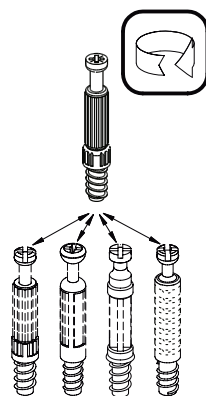
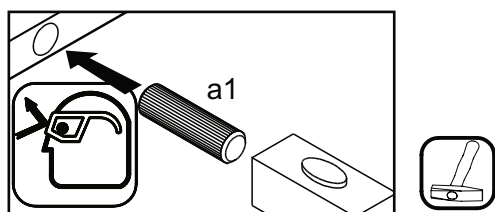
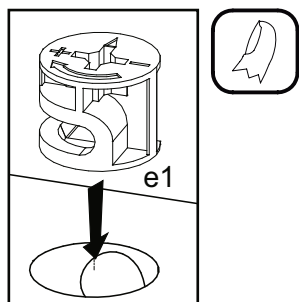
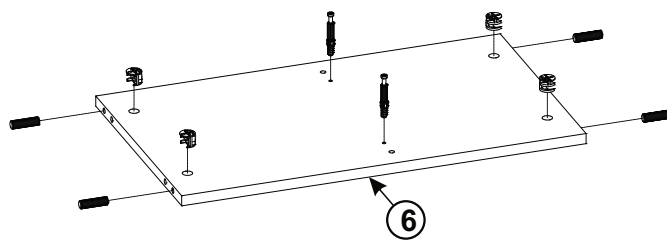
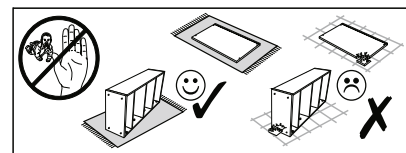

2

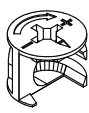
<b>A1</b> 8 x 35  x4	<b>E1</b> 15 x 12,5  x2
---------------------------------------------------------------------------------------------------------------	------------------------------------------------------------------------------------------------------------------

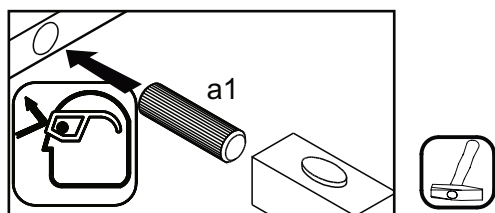
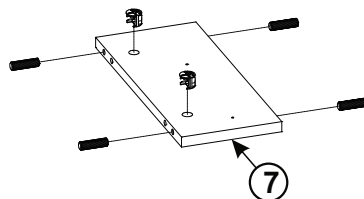
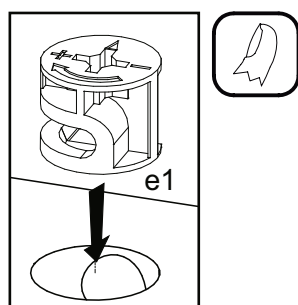
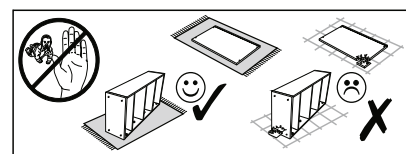

3

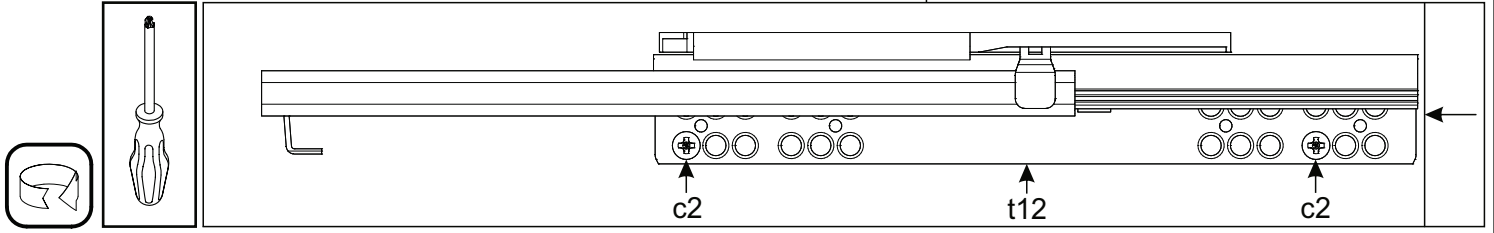
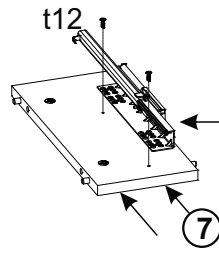
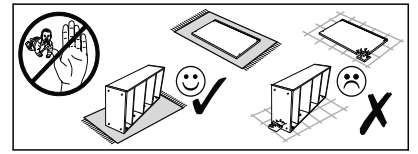
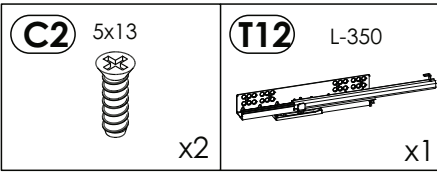

4

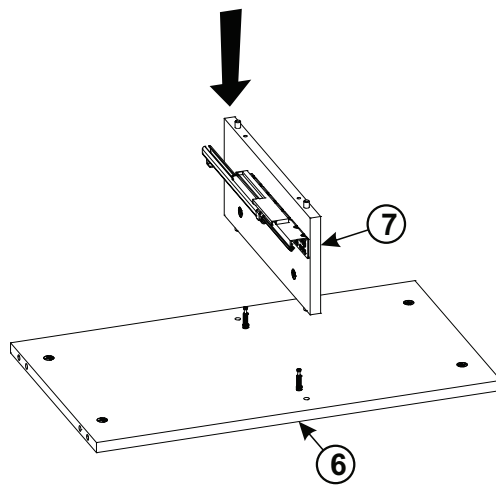
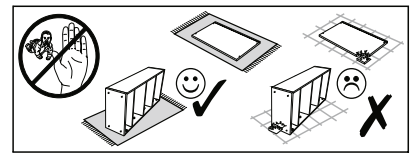
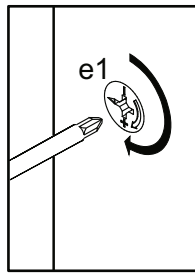
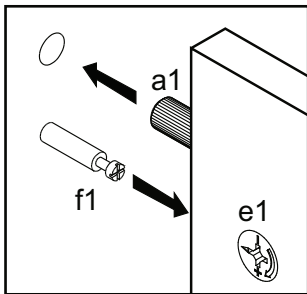

5

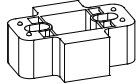
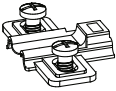
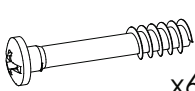
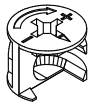
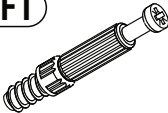
<p><b>A1</b> 8 x 35</p>  <p>x8</p>	<p><b>B4B</b></p>  <p>x3</p>	<p><b>BC15</b></p>  <p>x3</p>	<p><b>C12</b> 6,3 x 33</p>  <p>x6</p>
<p><b>E1</b> 15 x 12,5</p>  <p>x6</p>	<p><b>F1</b></p>  <p>x4</p>		

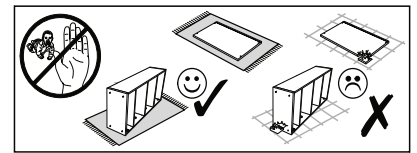

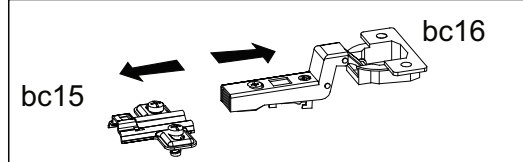

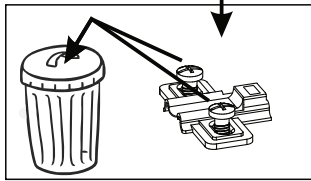

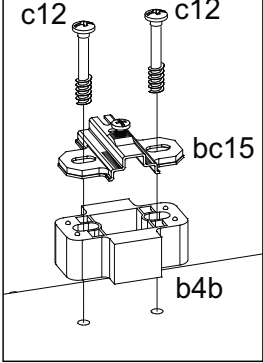



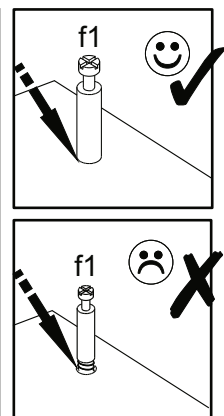
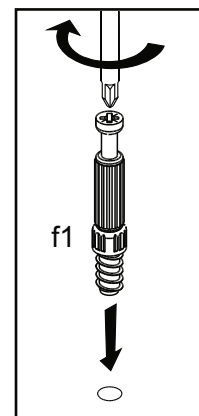
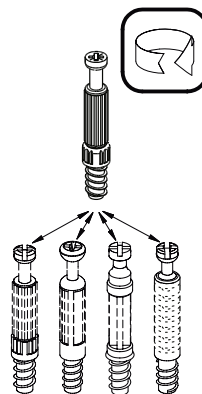
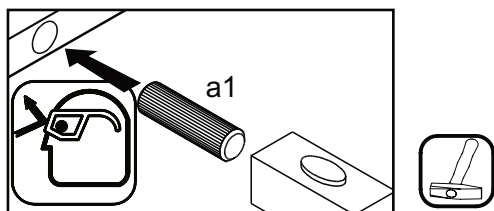
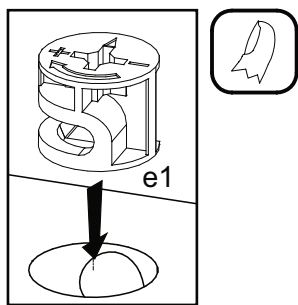
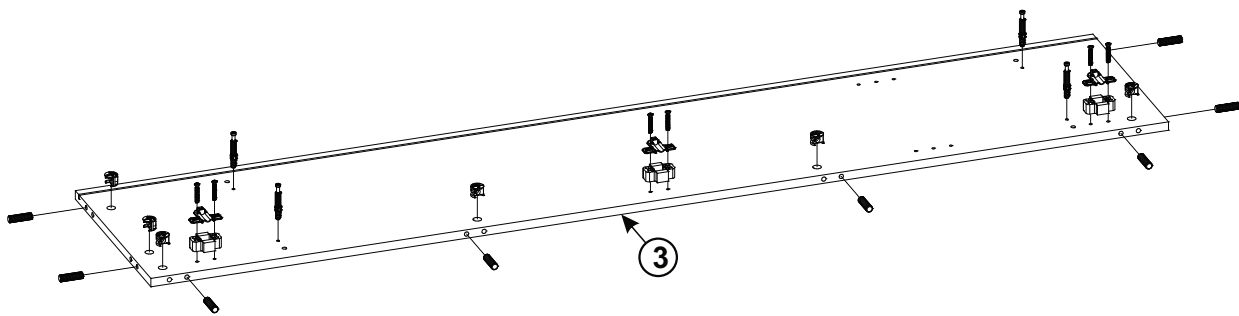

6

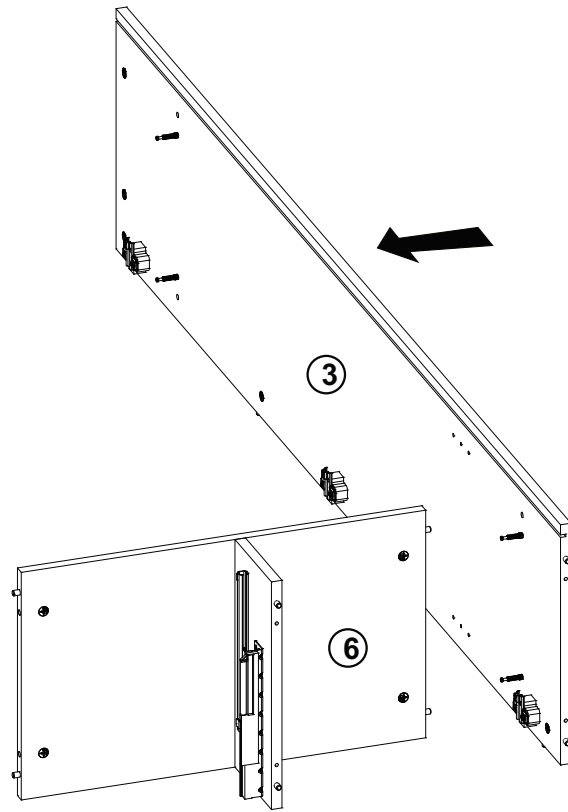
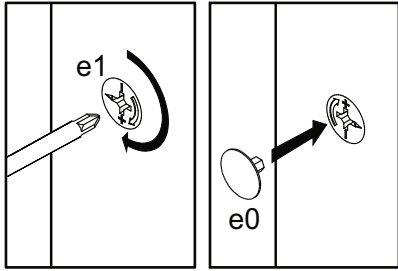
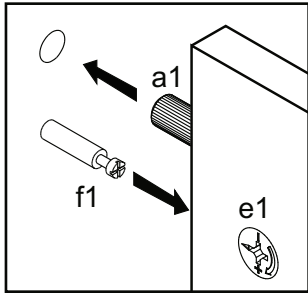
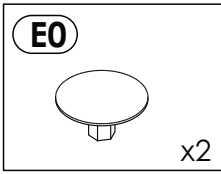

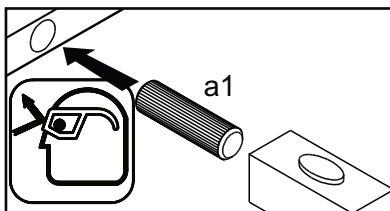
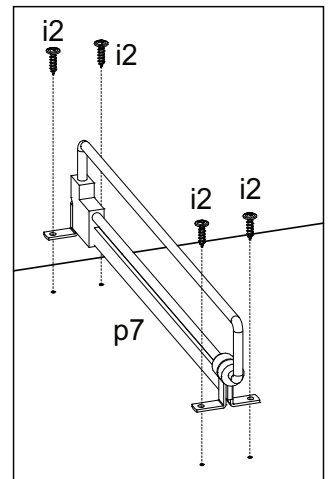
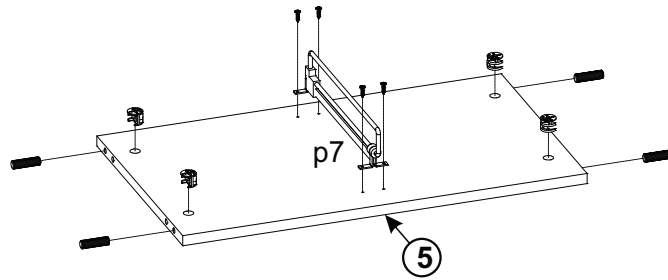
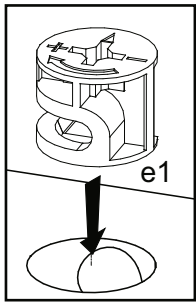
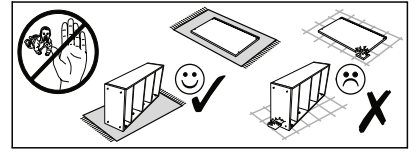
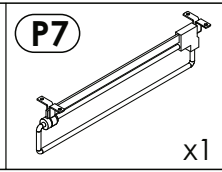
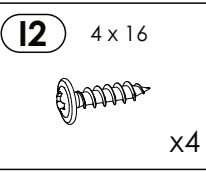
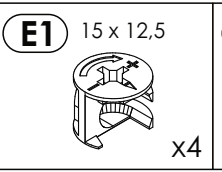
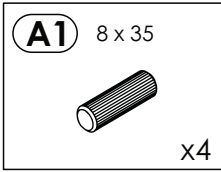

7

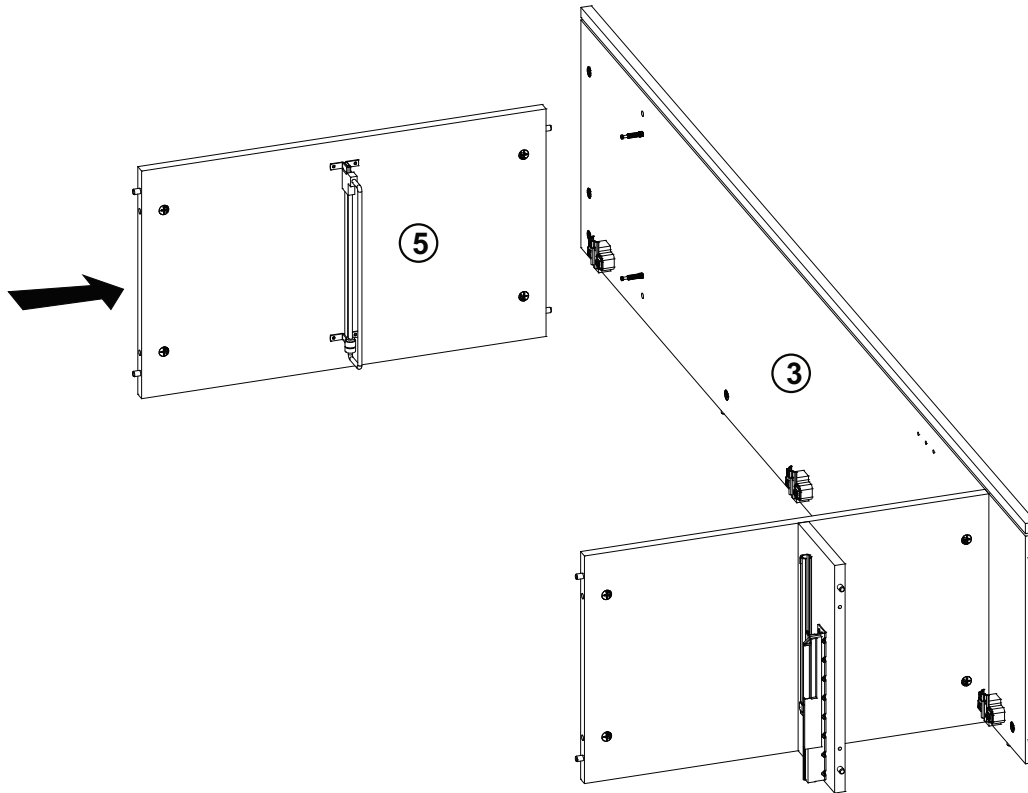
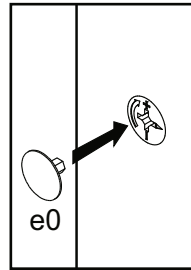
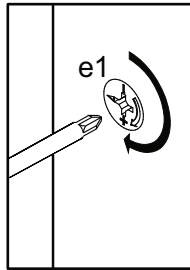
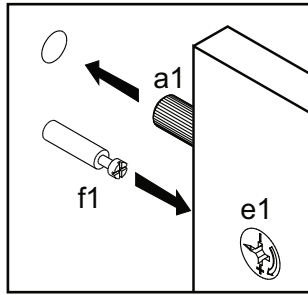
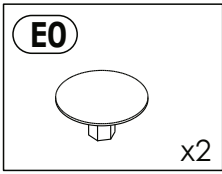

8

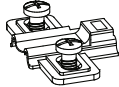

9

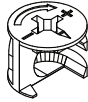
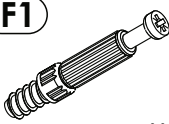
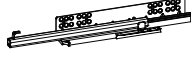
<b>A1</b> 8 x 35  x4	<b>BC11</b>  x3	<b>C2</b> 5x13  x2	<b>E1</b> 15 x 12,5  x2
<b>F1</b>  x4	<b>T12</b> L-350  x1		

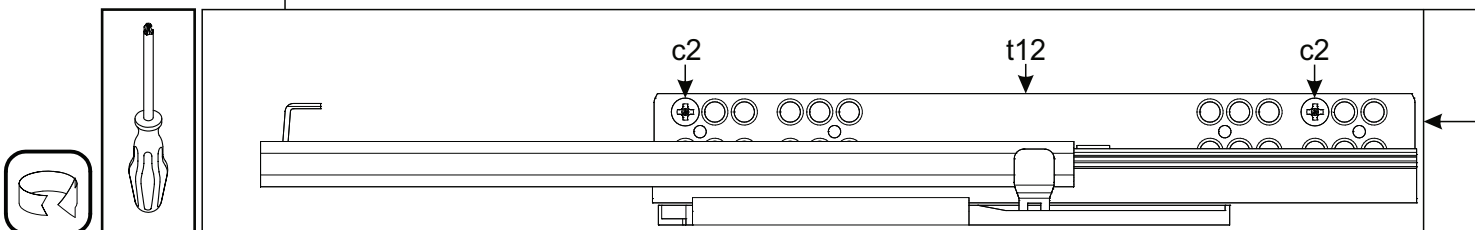
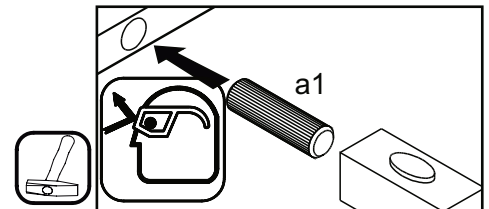
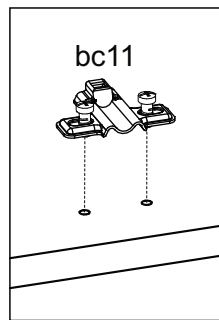
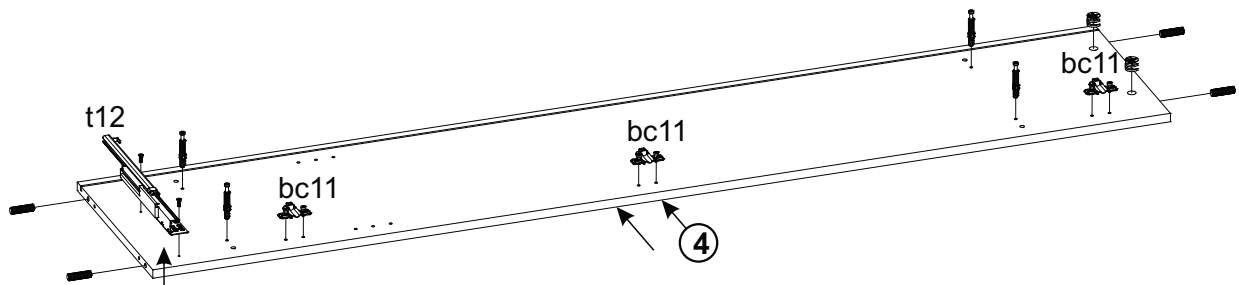
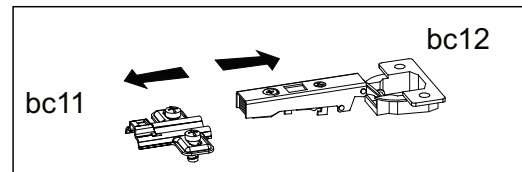
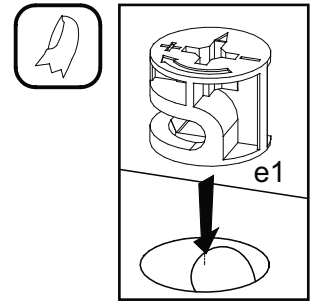
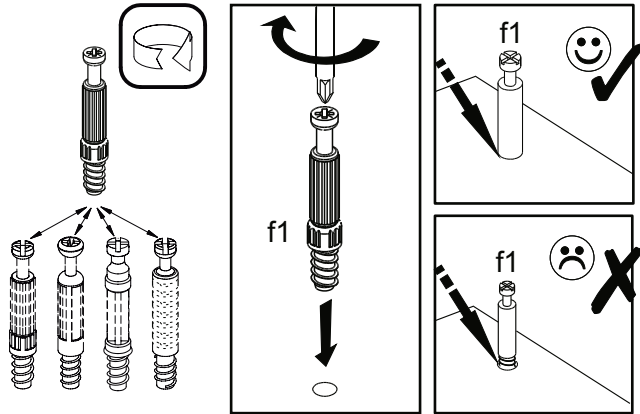
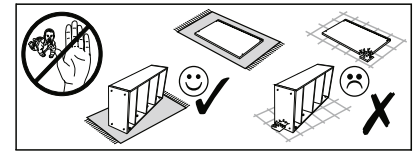

10

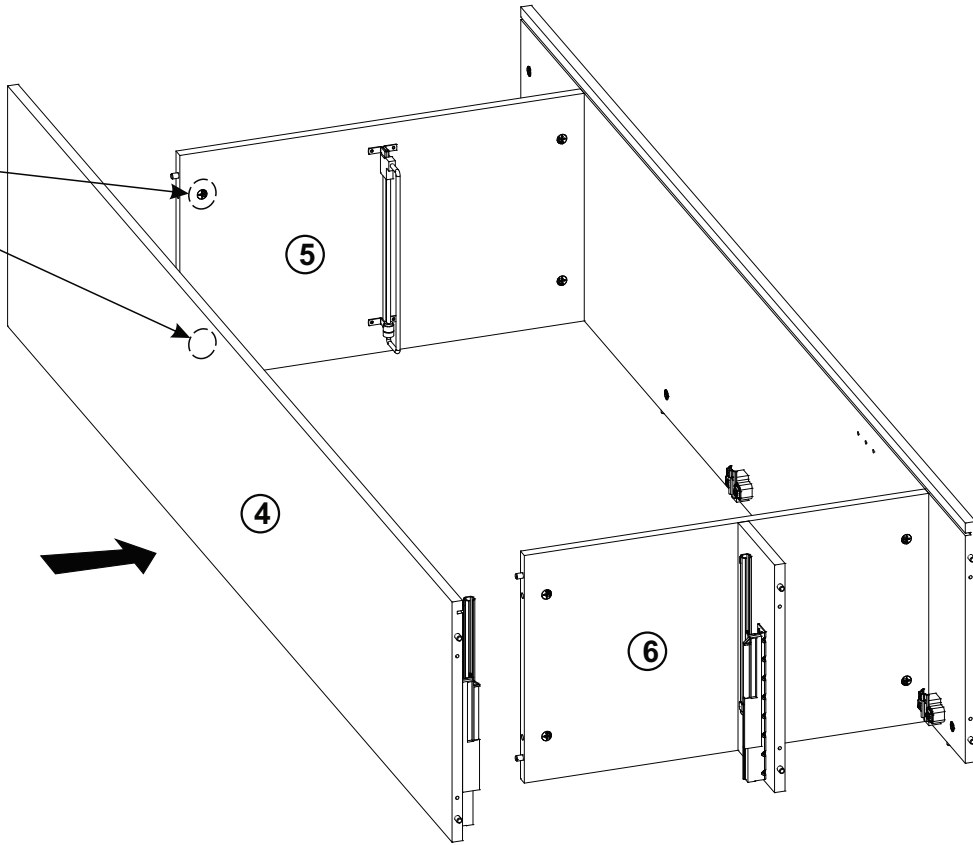
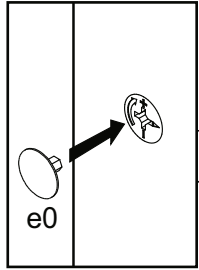
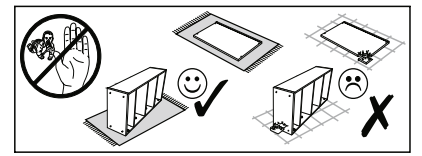
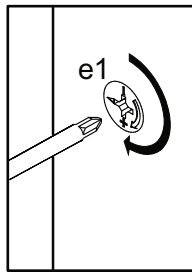
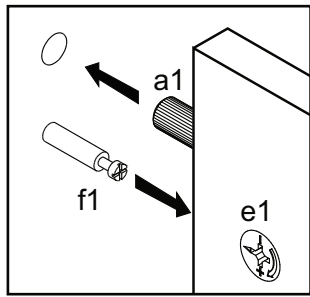
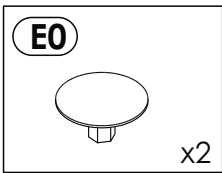

11

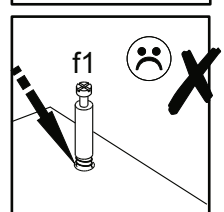
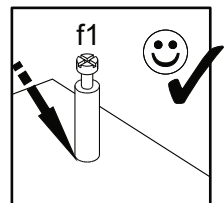
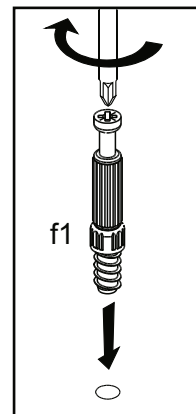
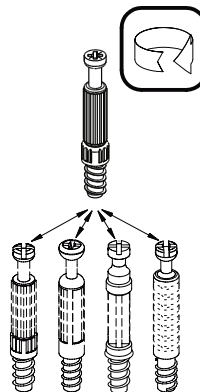
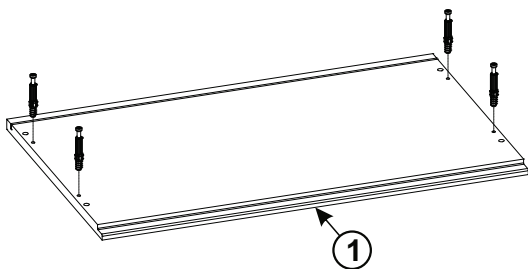
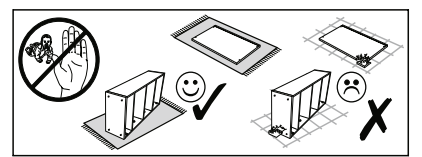
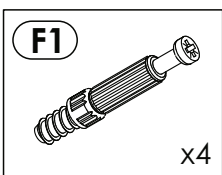



12

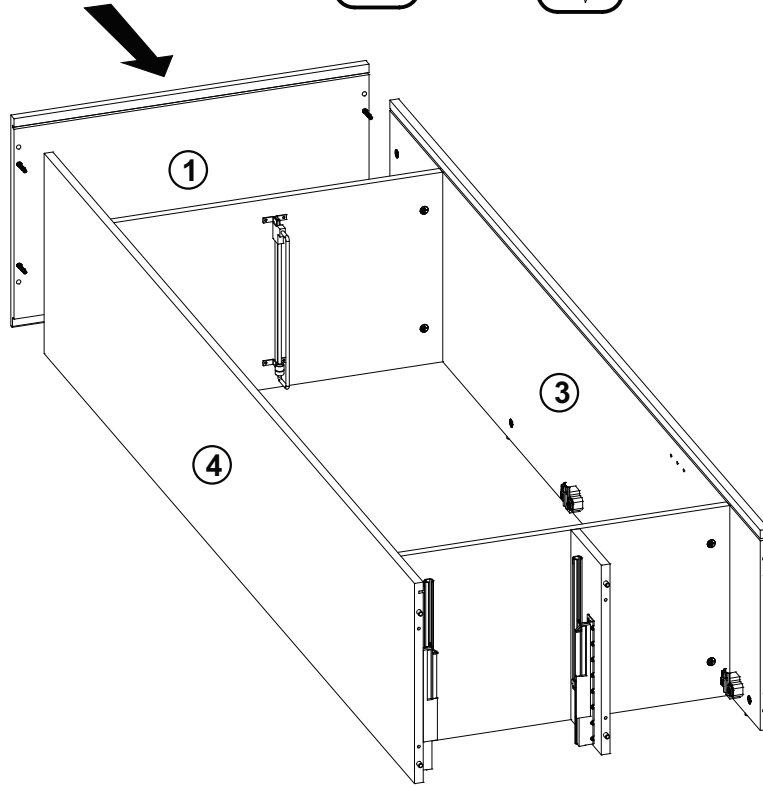
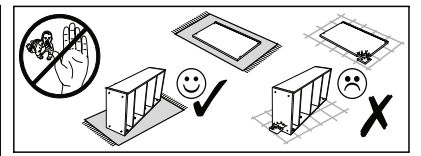
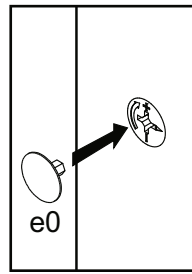
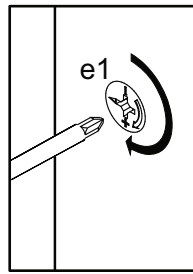
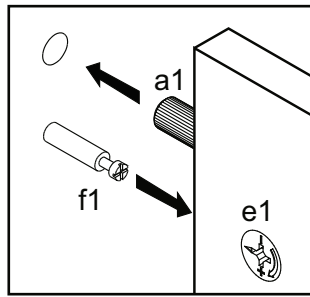
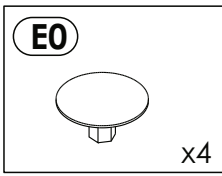

13

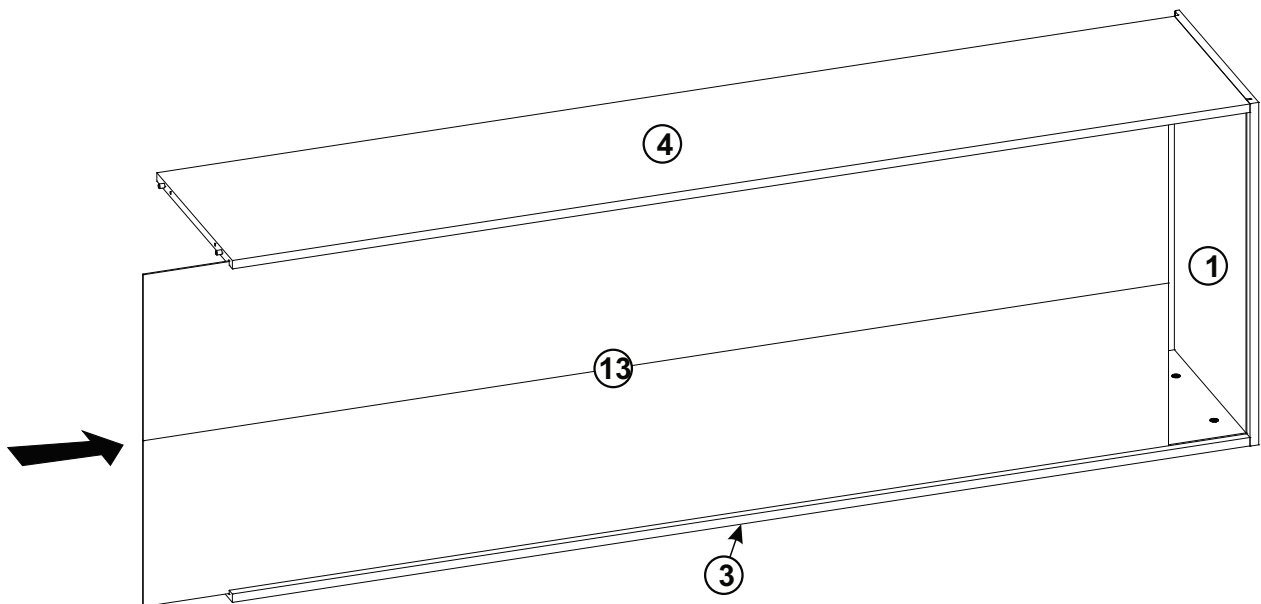
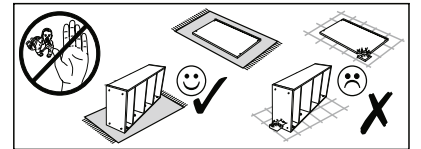

14

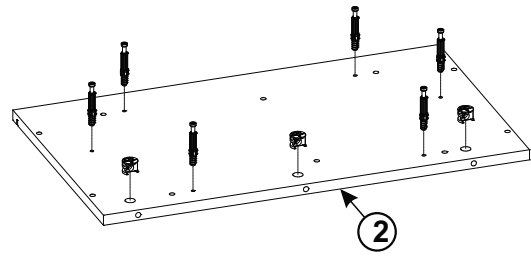
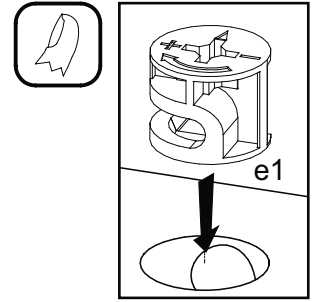
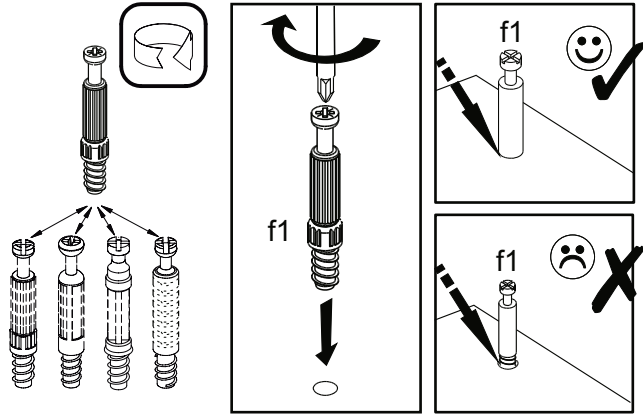
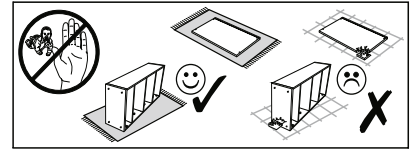
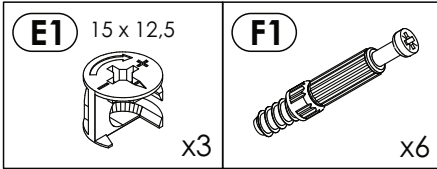

15

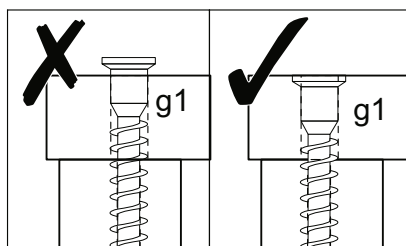
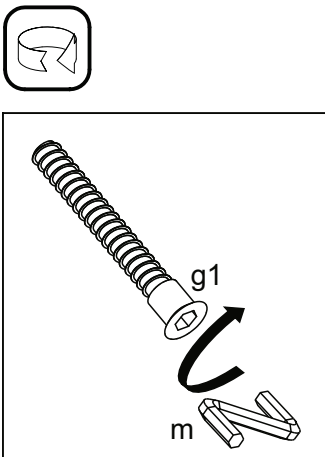
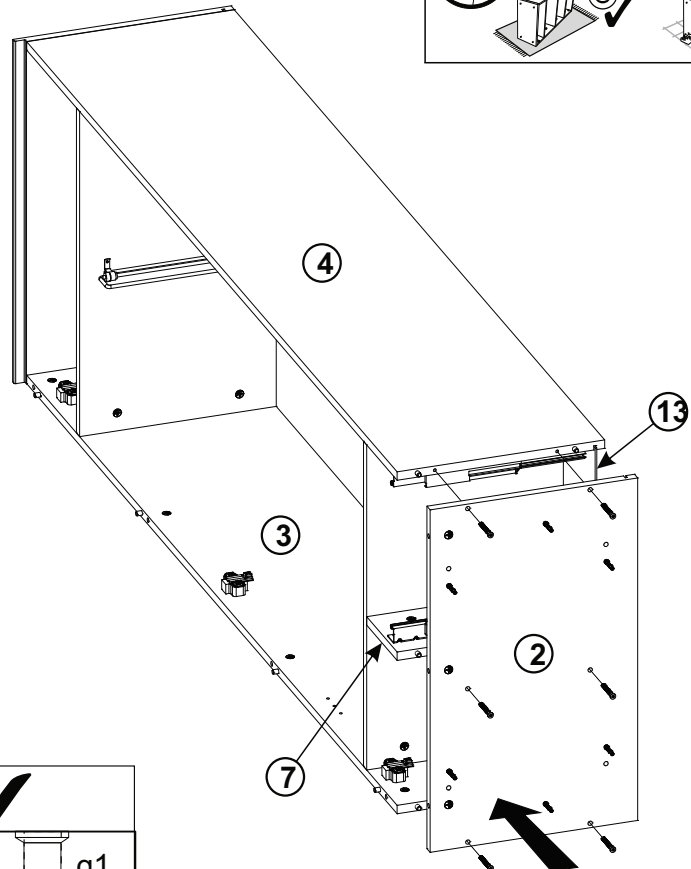
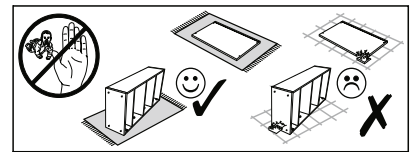
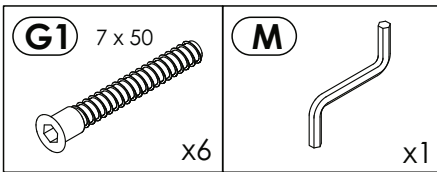

16

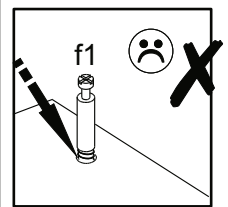
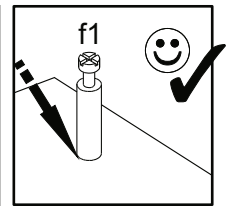
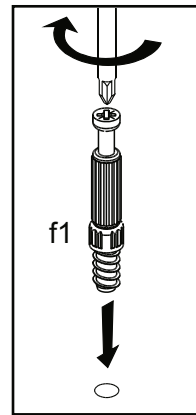
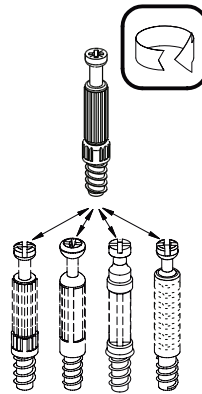
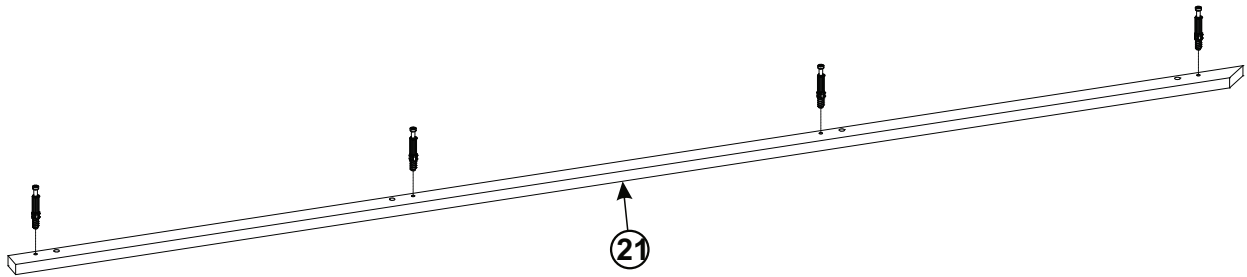
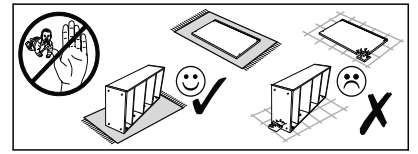
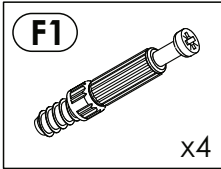

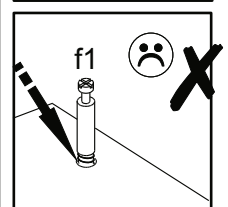
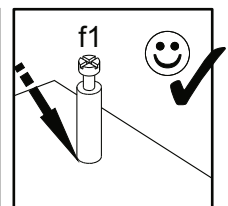
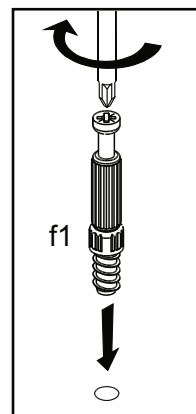
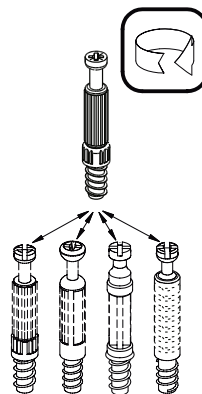
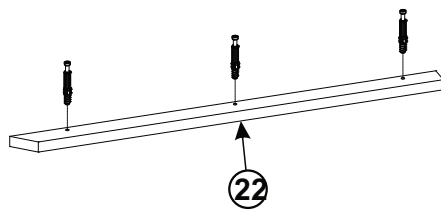
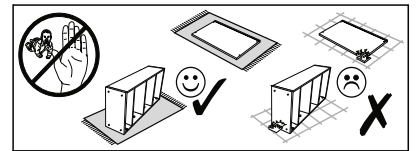
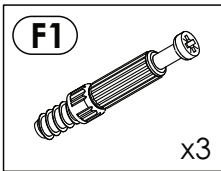

17

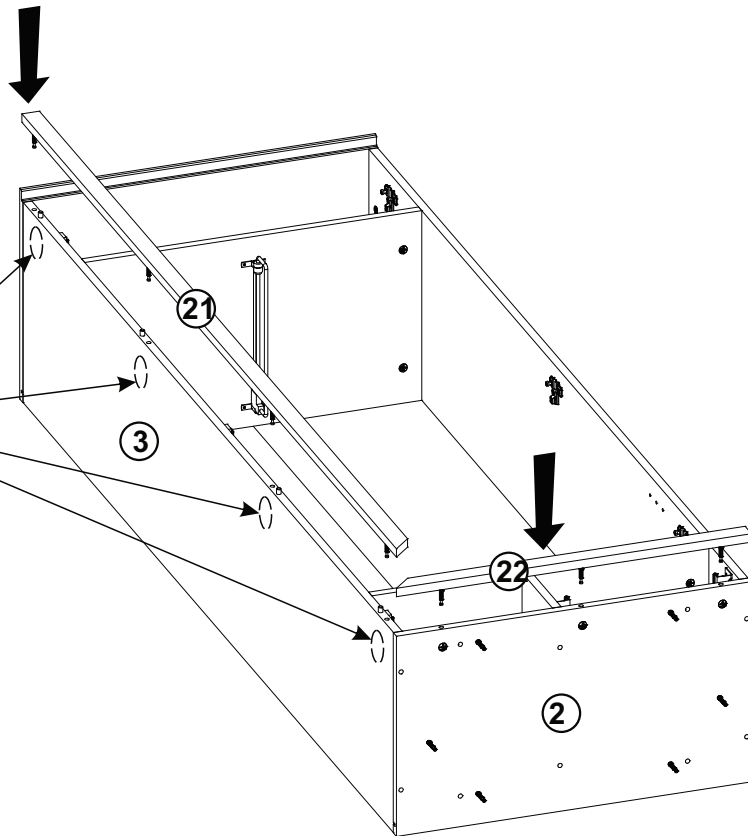
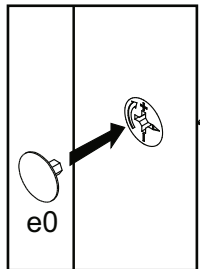
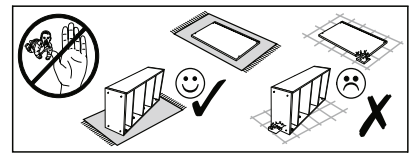
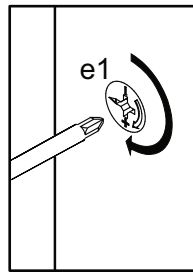
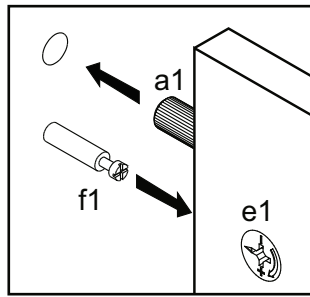
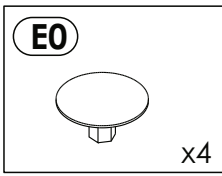

18



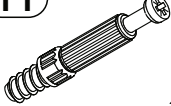

19

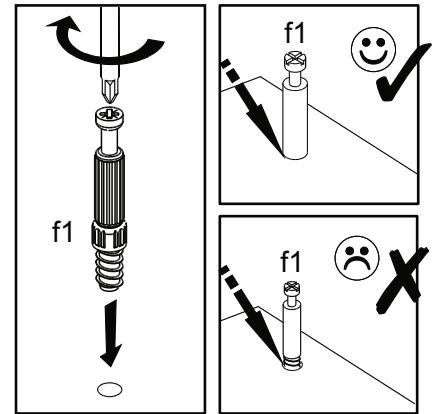
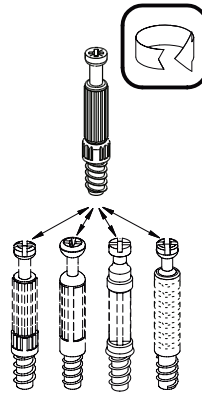
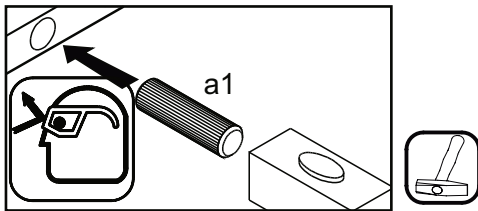
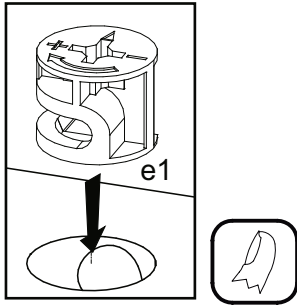
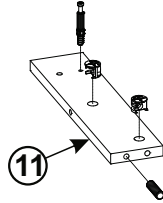
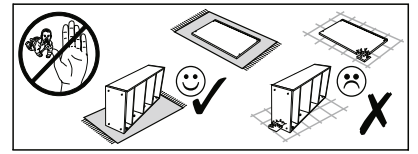
<b>A1</b> 8 x 35  x1	<b>E1</b> 15 x 12,5  x2	<b>F1</b>  x1
-------------------------------------------------------------------------------------------------------------	----------------------------------------------------------------------------------------------------------------	------------------------------------------------------------------------------------------------------

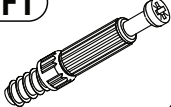

20

<b>A1</b> 8 x 35  x1	<b>E1</b> 15 x 12,5  x2	<b>F1</b>  x1
---------------------------------------------------------------------------------------------------------------	------------------------------------------------------------------------------------------------------------------	--------------------------------------------------------------------------------------------------------

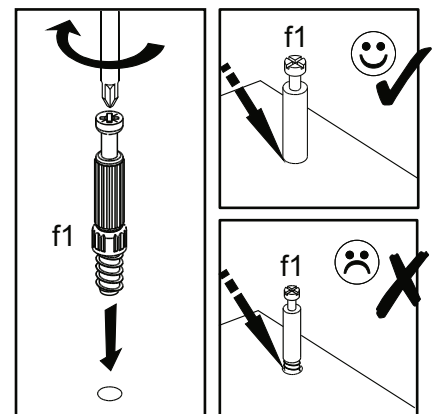
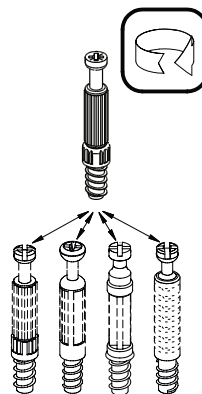
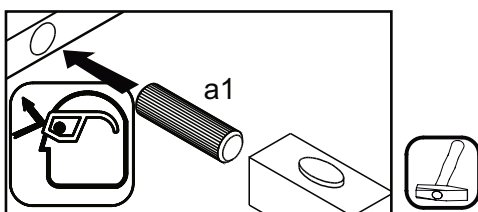
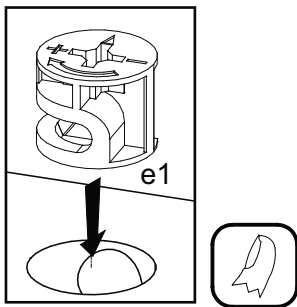
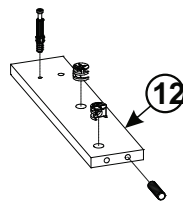
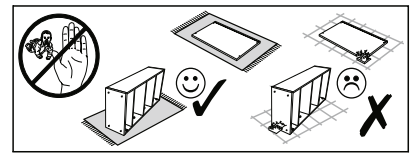

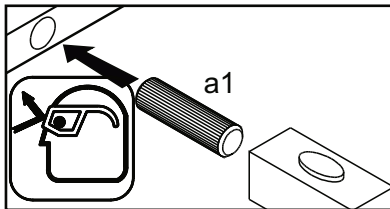
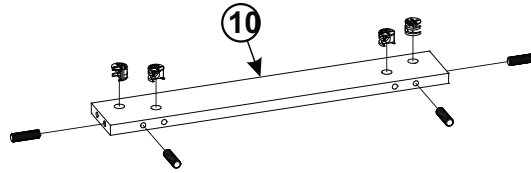
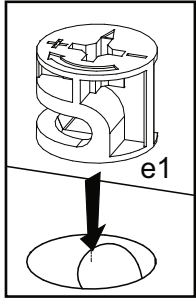
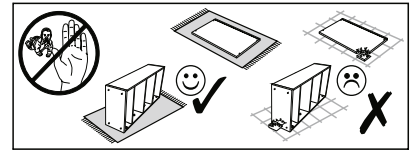
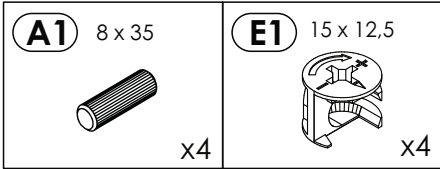

21

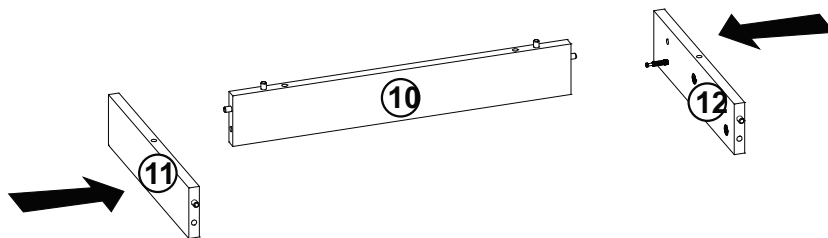
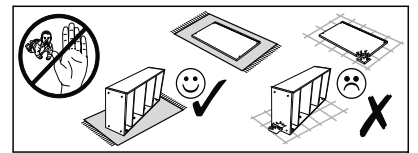
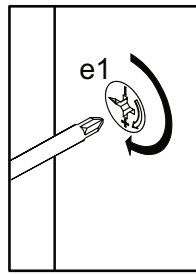
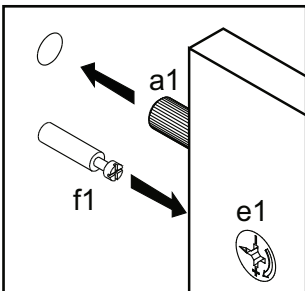

22

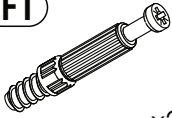

23

<p><b>A1</b> 8 x 35</p>  <p>x2</p>	<p><b>E1</b> 15 x 12,5</p>  <p>x2</p>	<p><b>F1</b></p>  <p>x2</p>
---------------------------------------------------------------------------------------------------------------------	------------------------------------------------------------------------------------------------------------------------	-------------------------------------------------------------------------------------------------------------

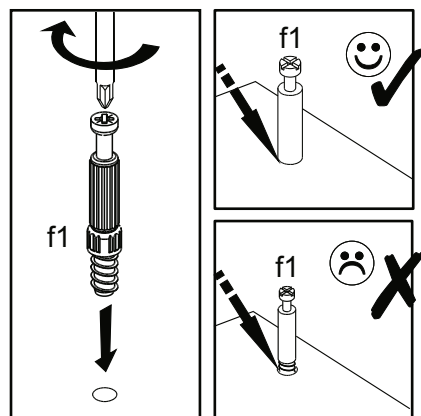
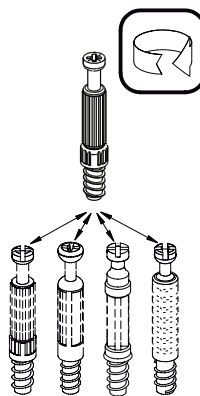
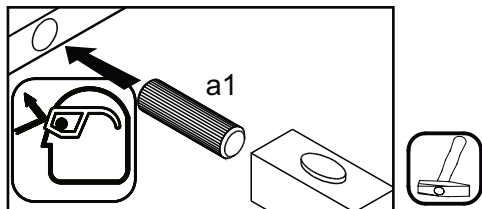
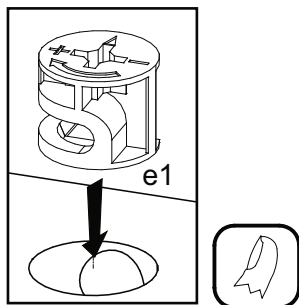
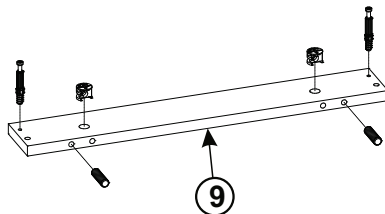
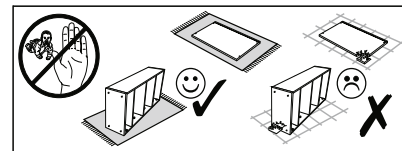

24

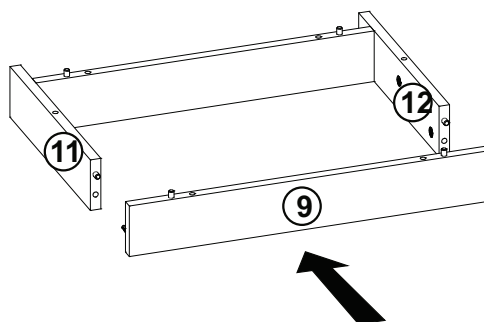
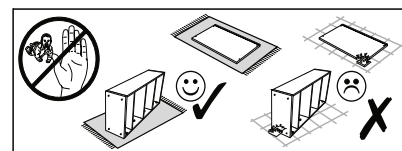
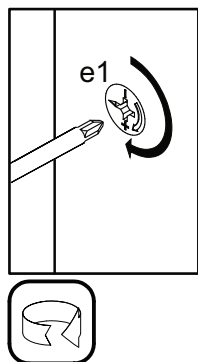
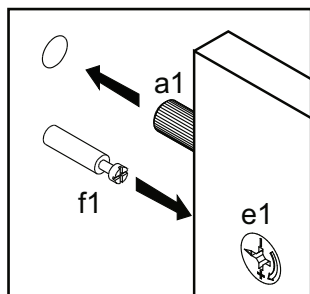

25

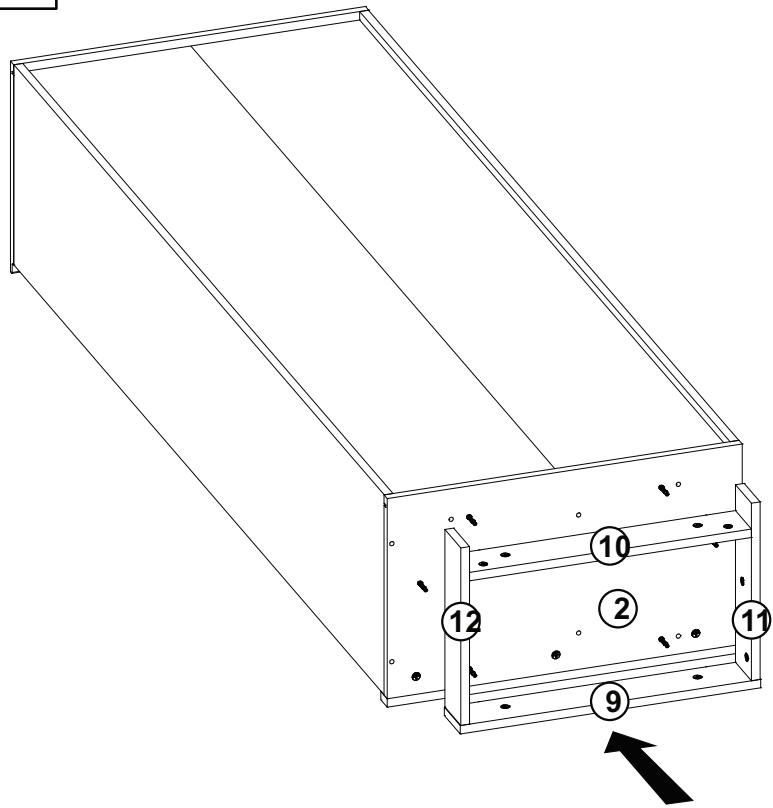
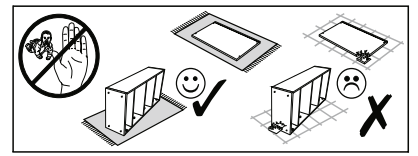
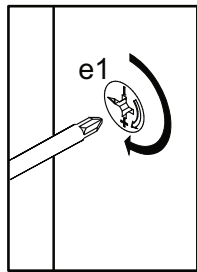
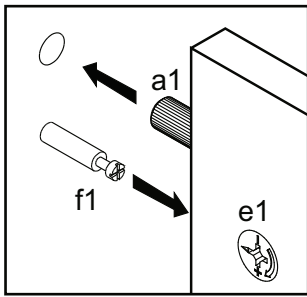

26

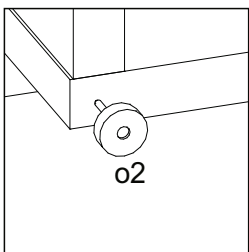
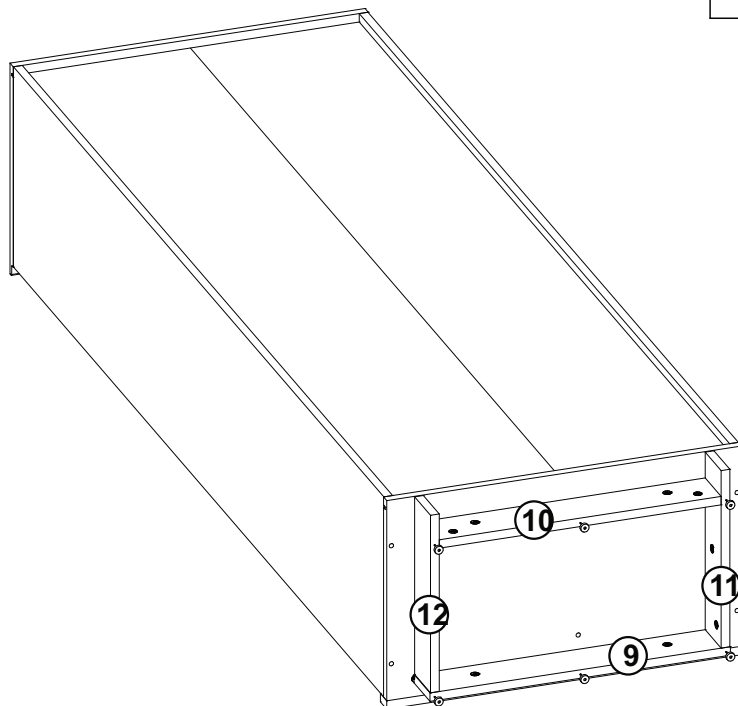
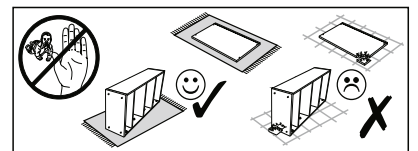
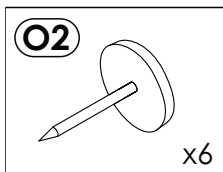



27



A=B

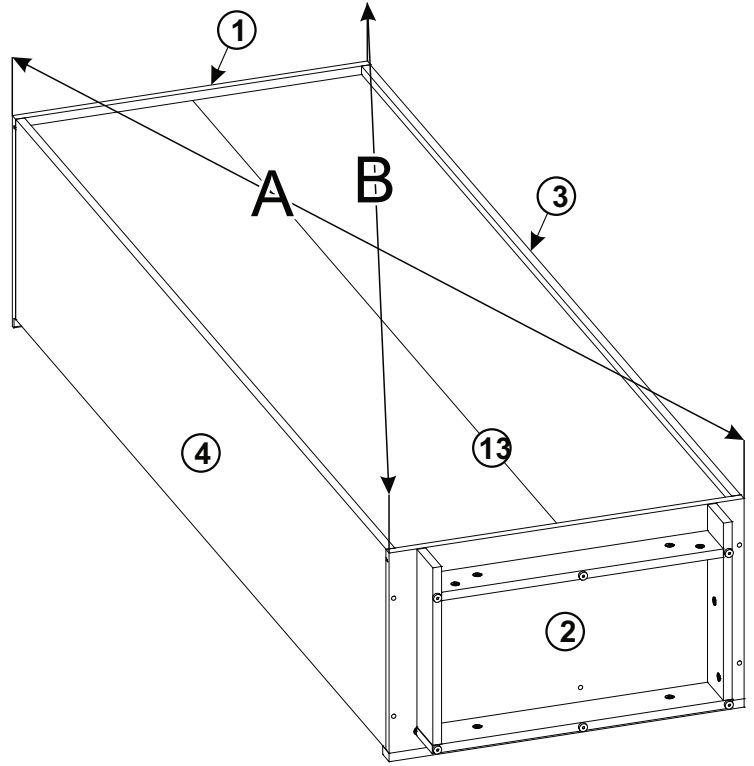
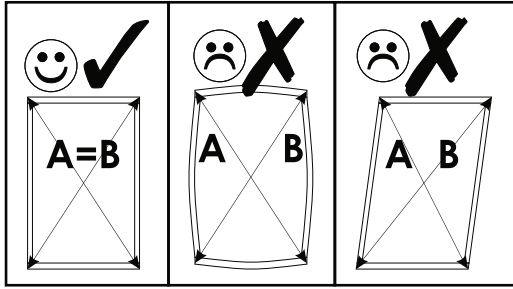

28

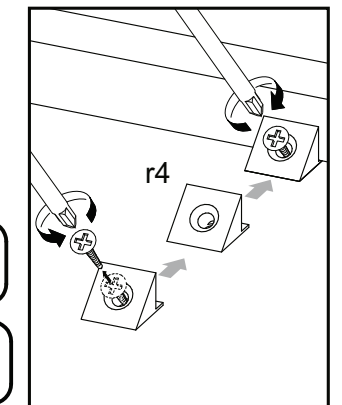
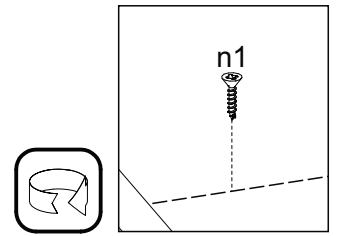
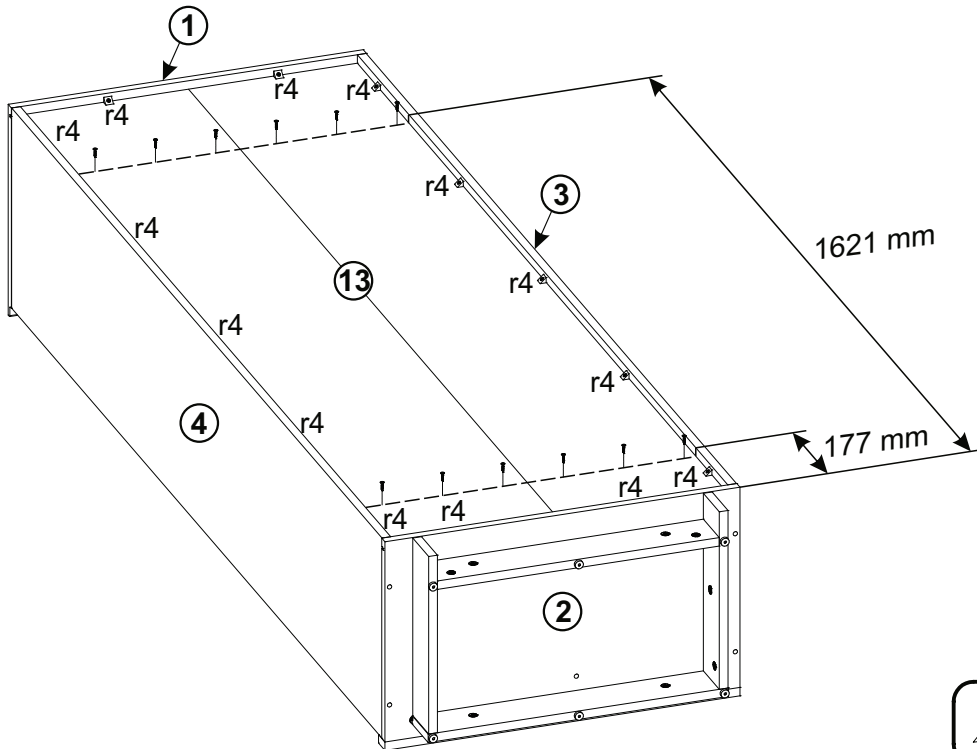
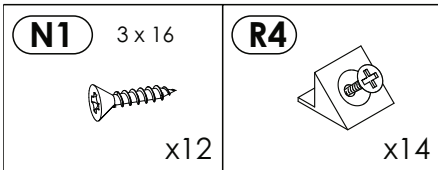

29

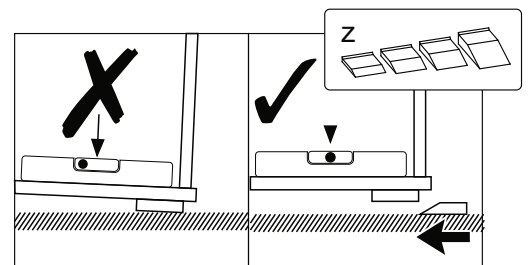
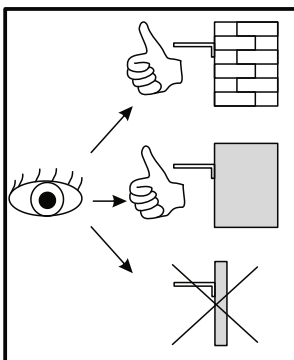
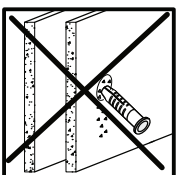
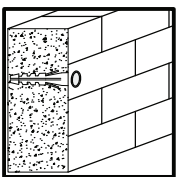
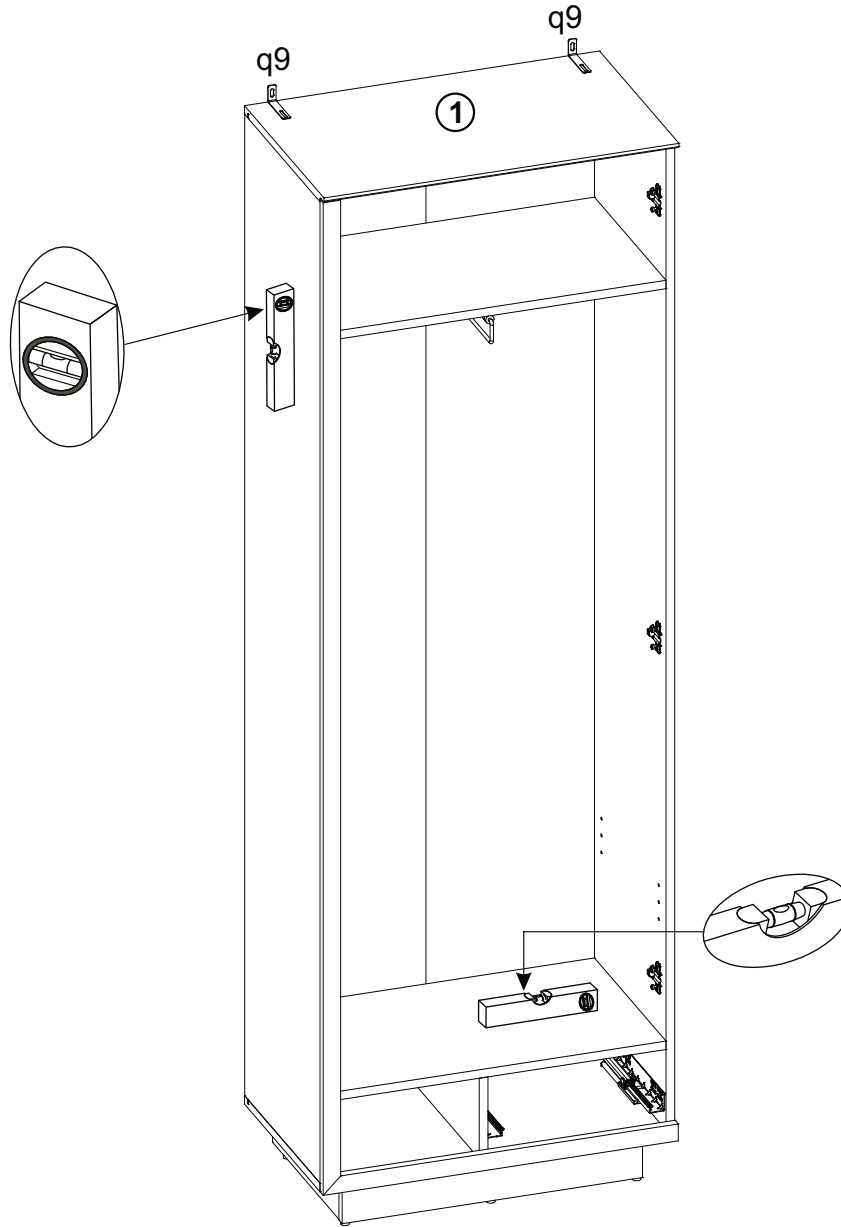
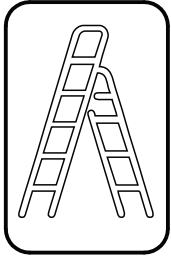
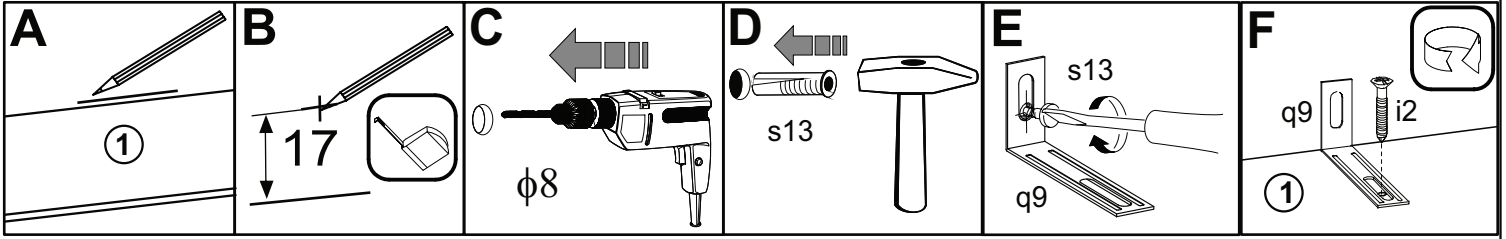
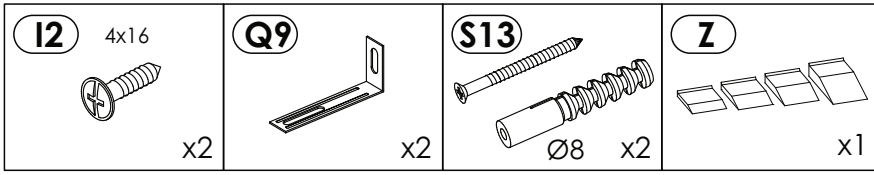

30

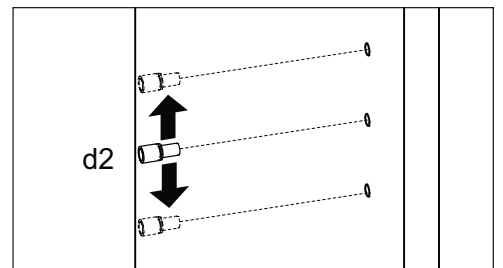
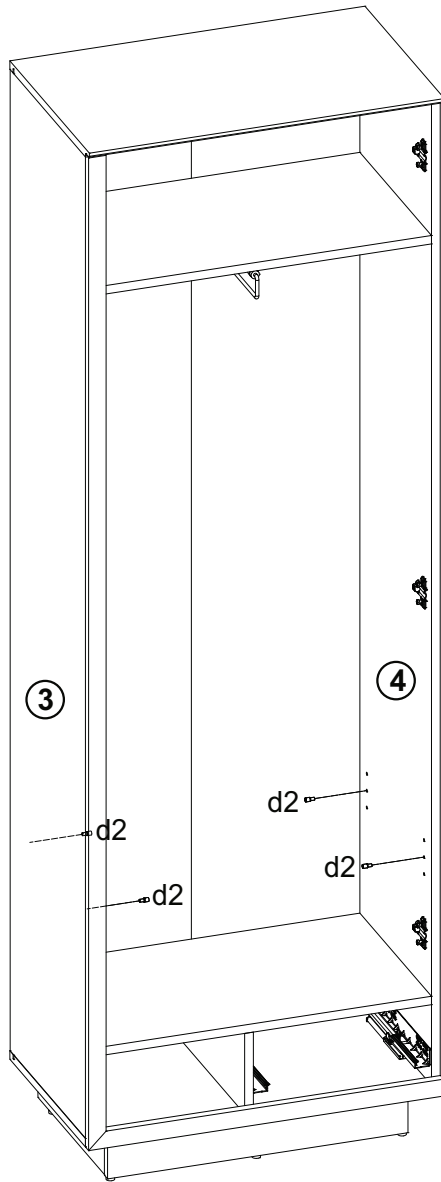
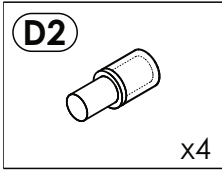

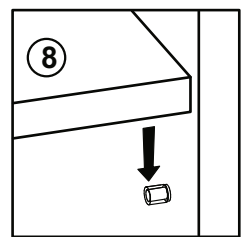
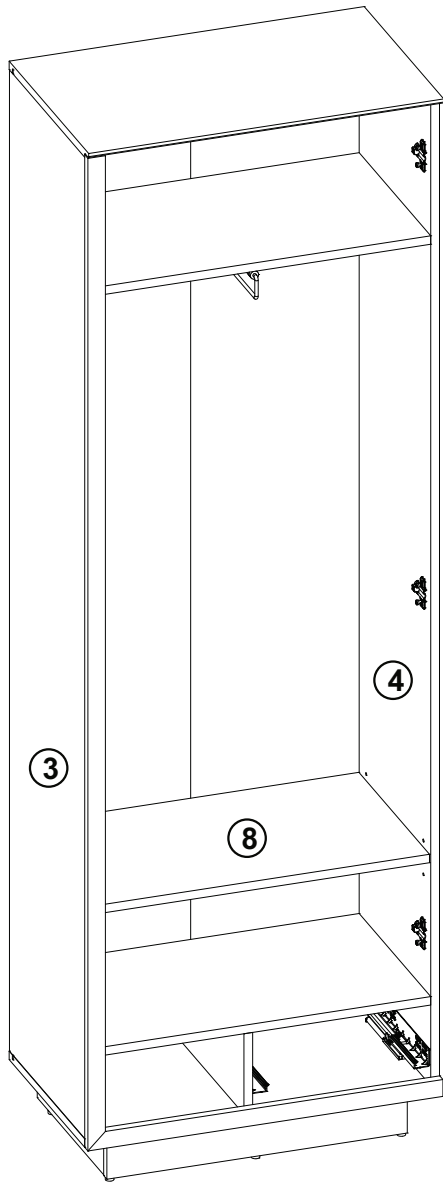

32

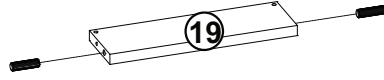
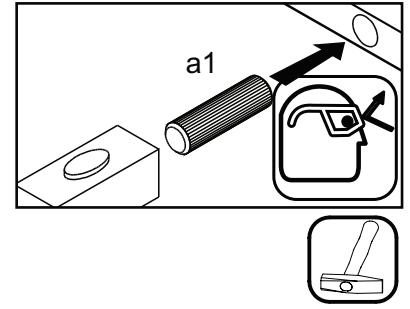
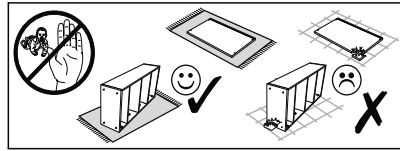
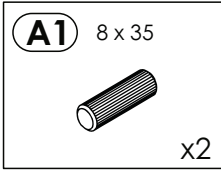

33

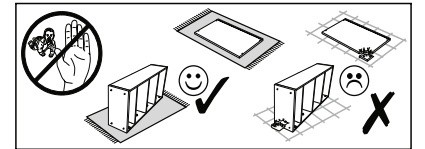
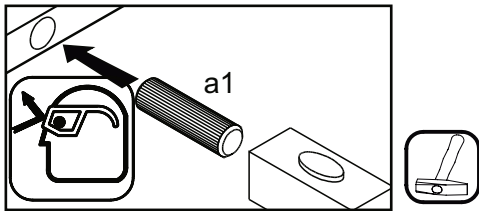
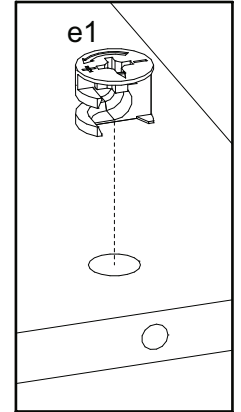
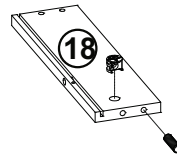
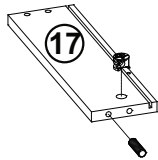
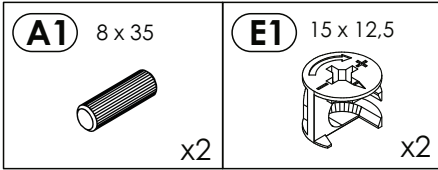

34

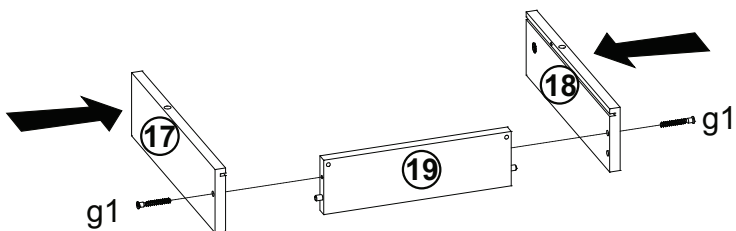
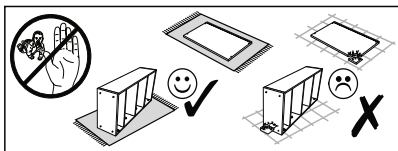
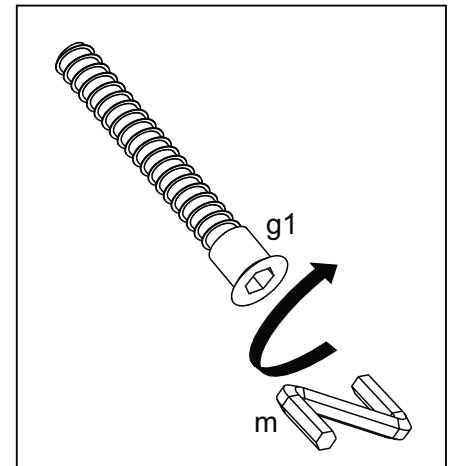
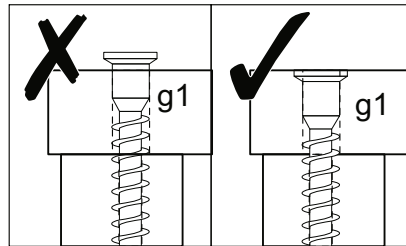
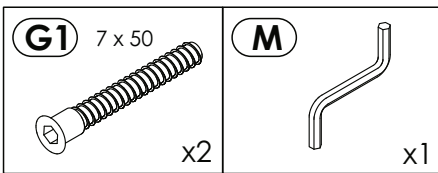

35

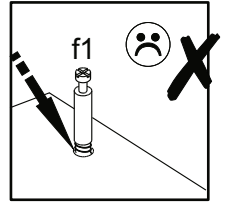
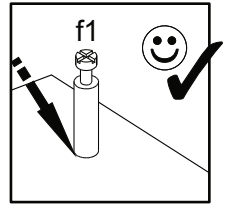
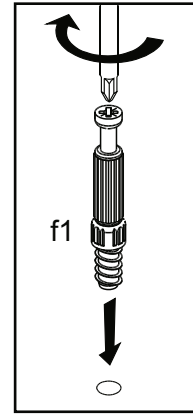
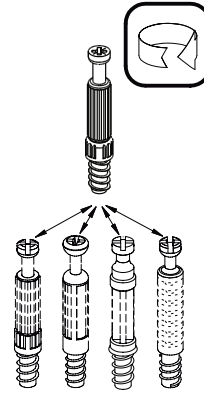
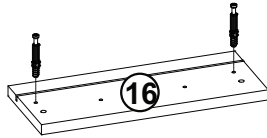
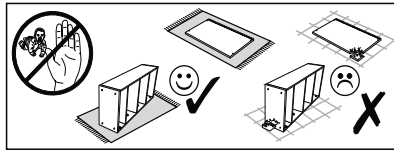
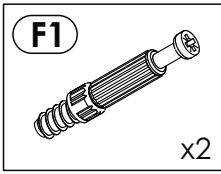

36

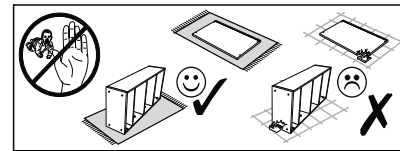
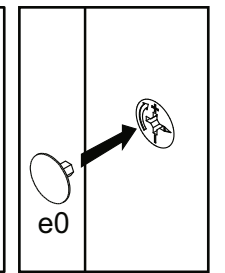
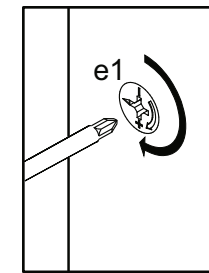
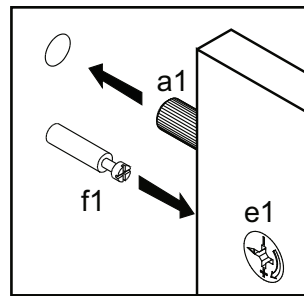
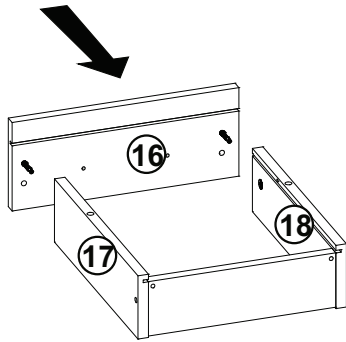
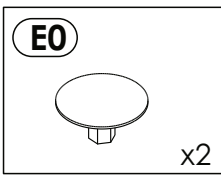

37

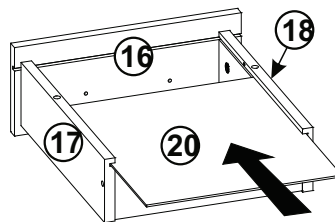
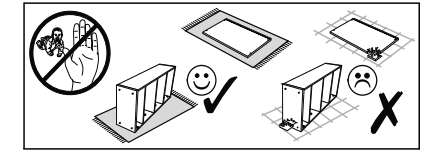

38

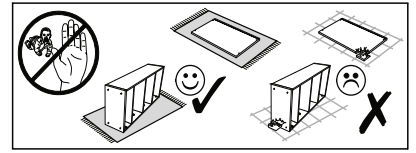
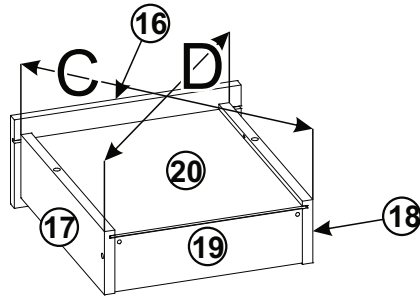
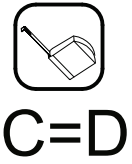

39

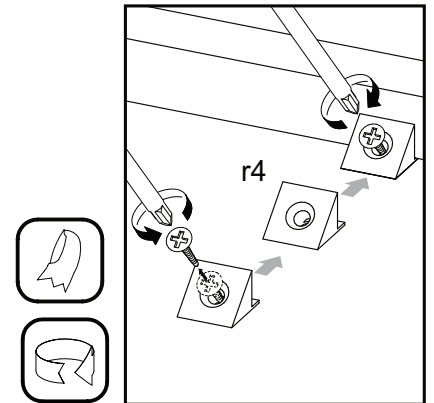
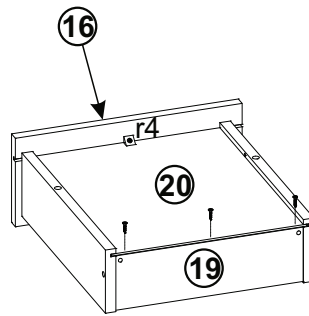
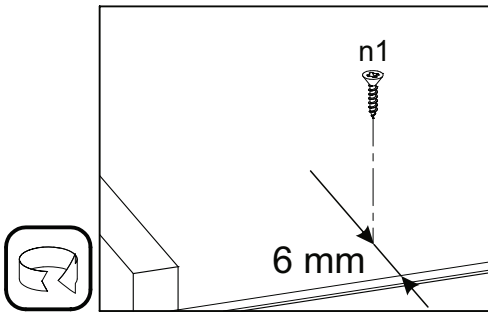
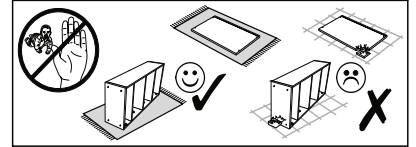
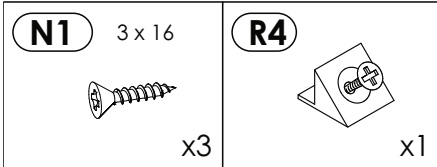

40

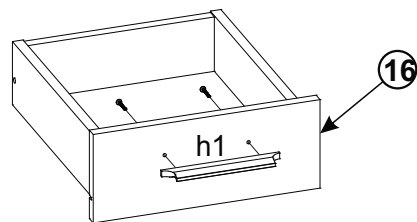
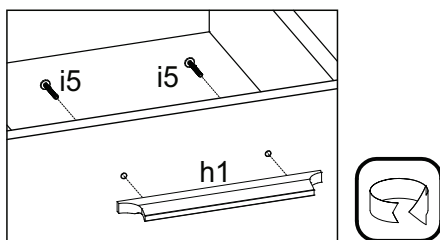
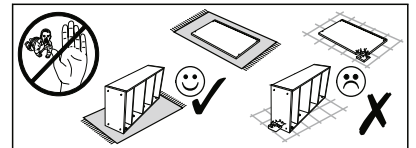
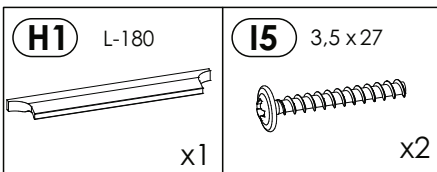

41

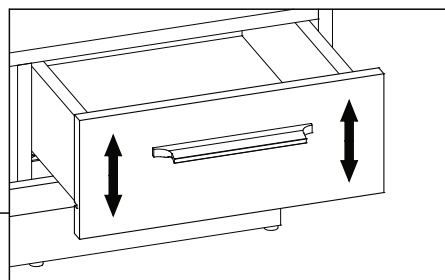
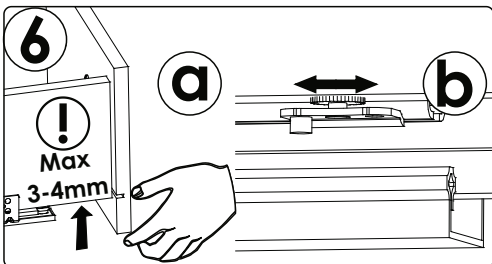
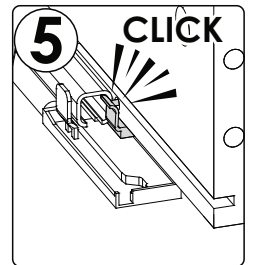
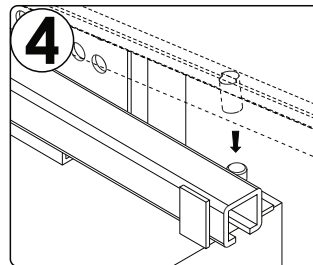
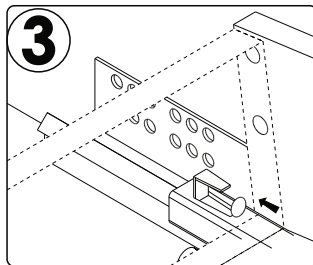
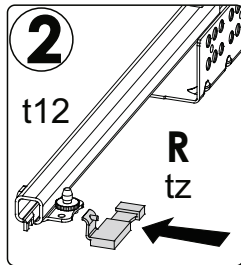
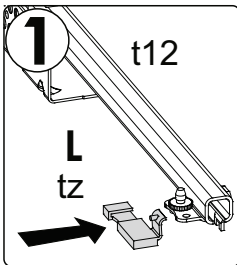
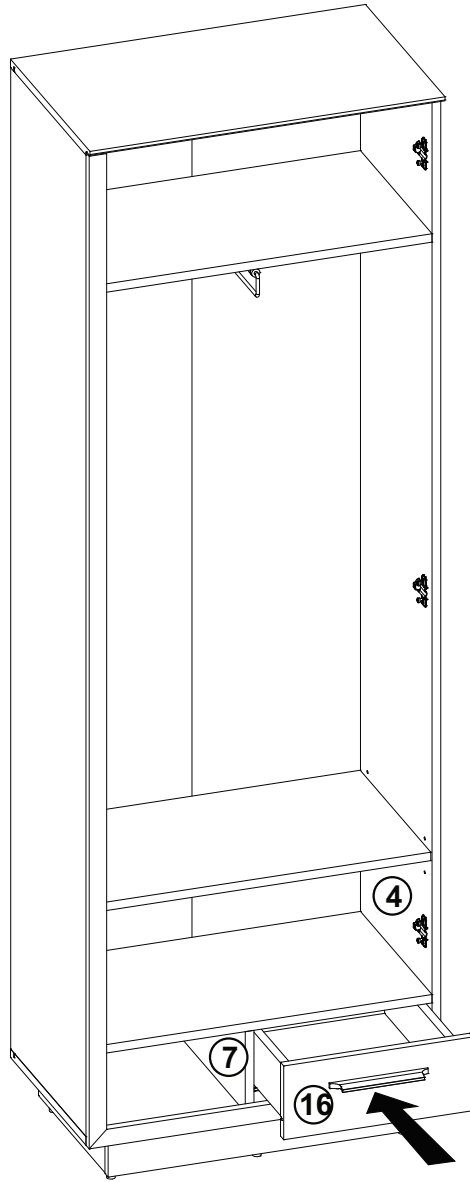
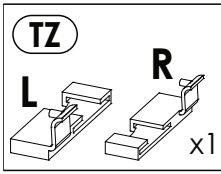



42

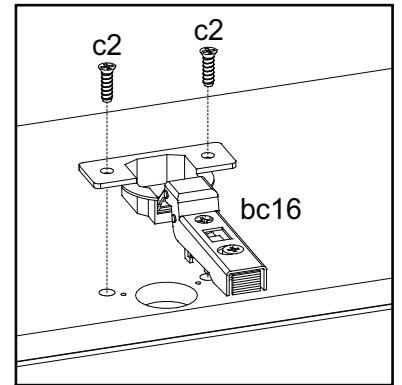
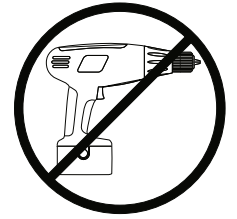
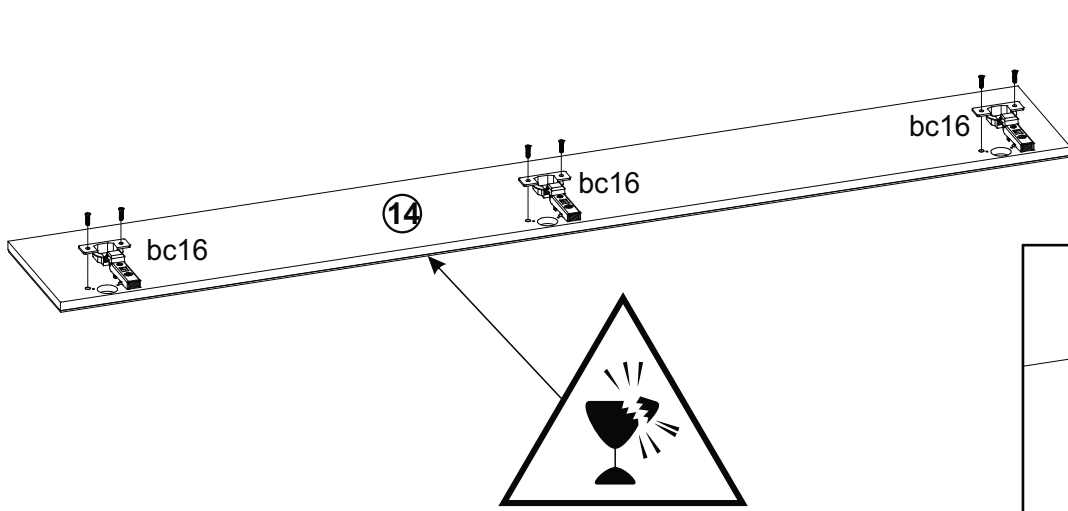
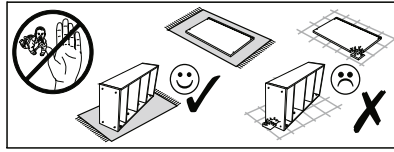
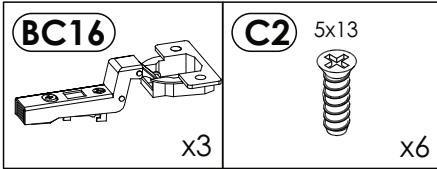

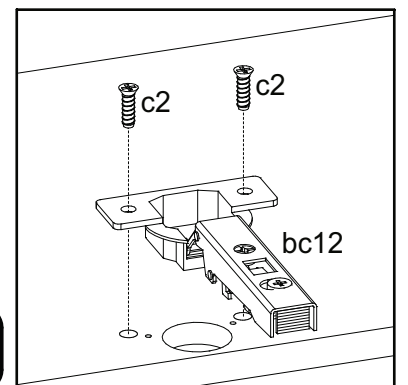
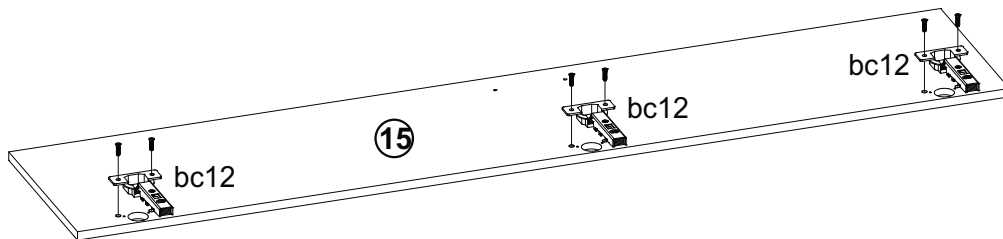
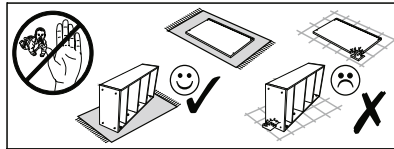
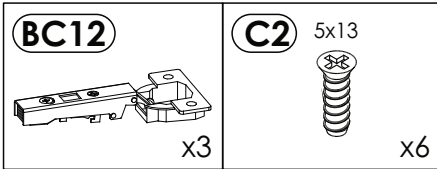

43

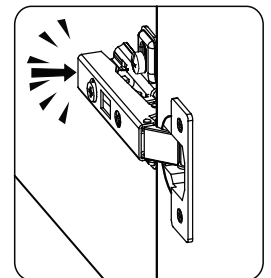
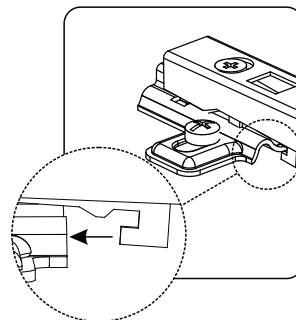
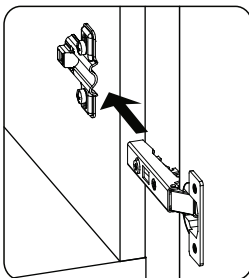
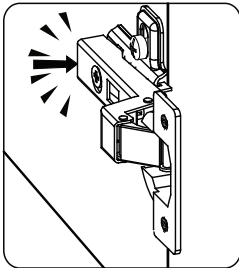
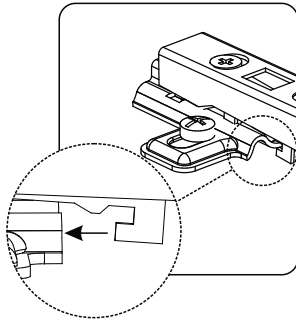
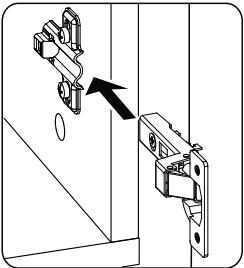
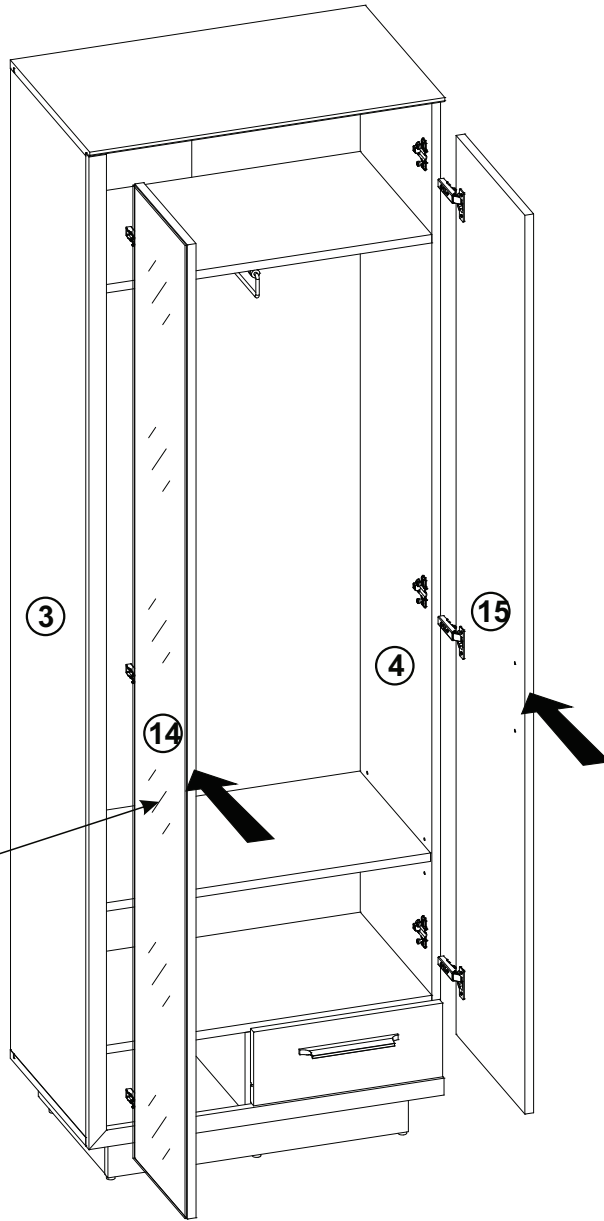
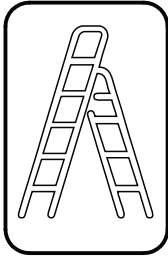



45

<b>H1</b> L-180  x1	<b>I5</b> 3,5x27  x2
------------------------------------------------------------------------------------------------------------	-------------------------------------------------------------------------------------------------------------

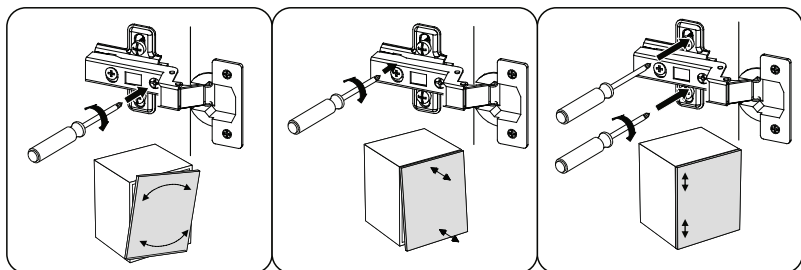
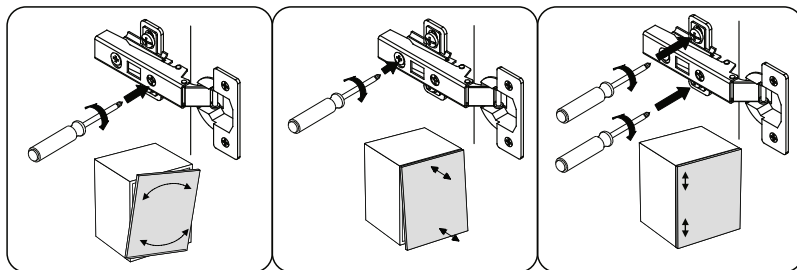
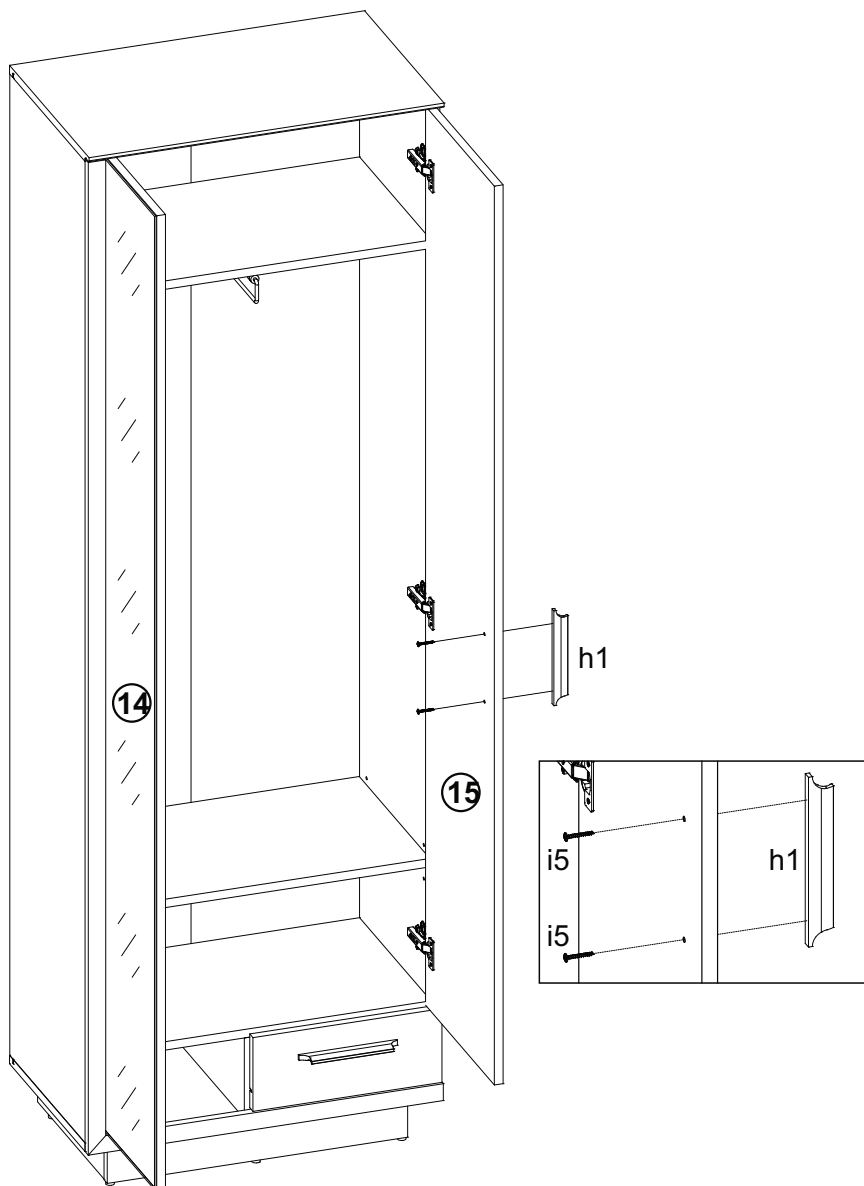

LKZ 80236

Modellname / Model name / Nom du modèle / Modellnamn / Nome modello / Název modelu / Modelnaam / Ime modela / Numéro Modelo / Modell neve / Название модели / Názov modelu / Ime modela / Denumire model / Наименование на модела / Nazwa modelu

**SynnaX**

Modellnummer / Number / Numéro du modèle / Numero / Номер на модела / modello / Číslo modelu / Modell száma / Ěíslo modelu / Številka modela / Număr model / Broj modela / Modelnummer / Numer modelu

2134-310-84

Туре / Типо / Típus / Тур / Тип / Tip

**310**

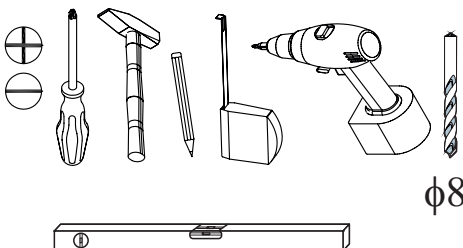
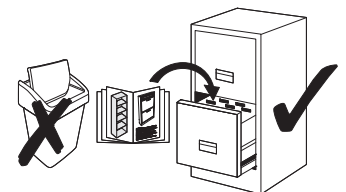
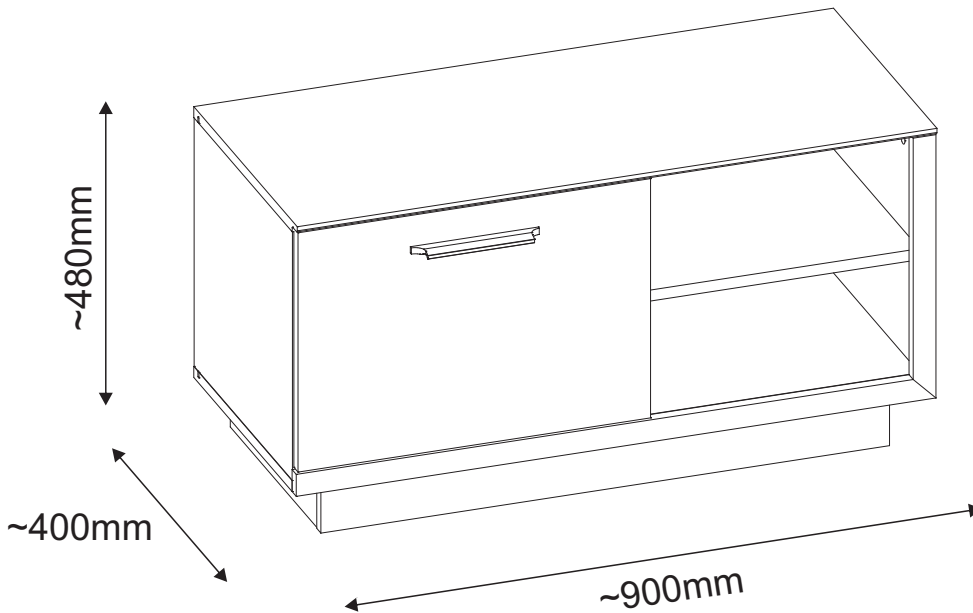
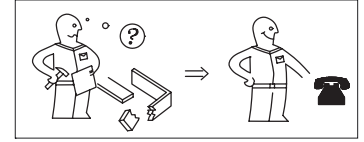
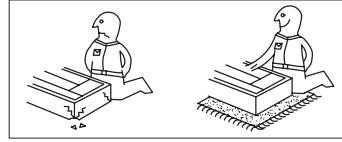
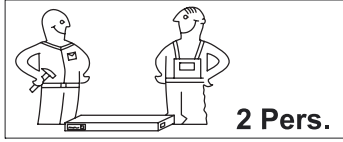

festziehen / tighten / Затягнете / serrer / stringere / utåhnut / vasttrekken / zategnuti / strångere / zwiázac / zacisnac / szorosan meghúzni / pevne dotiahnut' / trdno pritegniti / затянуть / dra át

eindrücken / press in / enfoncer / wcisnac / ribattere / zatlačit / Вкарайте / indrukken / benyomni / stlačit' / vtisniti / tryck in / introducere prin apă sare / вдавить

ausmessen / measure / mesurer / misurare / opmeten / izmeriti / miara / kimérni / izmeriti / măsurare / измерить / změřit / Измерете / mät upp / zmierzyc



drücken / press / presser / stisknout / Keren - omdraaien / Girare - Ruotare / Okrenuti - ubrnuti / Retourner - renverser / Turn over - turn around / Otoctc - obratce / Zavъртете - обвъртете / Obmrte list / întoarceți - rotiți / Vrid runt - vänd / прокрутить - повернуть / otočit - obrátit / elforgatni - megfordítani

einschlagen / hammer in / bevern / sla in / frapper au marteau / infossare / Zabit' / zarazit / Набийте / zabiti / wbić / introducere prin bătaie / забить / zatloct

Drehen - wenden / przekrećić - odwrócić / Keren - omdraaien / Girare - Ruotare / Okrenuti - ubrnuti / Retourner - renverser / Turn over - turn around / Otoctc - obratce / Zavъртете - обвъртете / Obmrte list / întoarceți - rotiți / Vrid runt - vänd / прокрутить - повернуть / otočit - obrátit / elforgatni - megfordítani

Modellname / Model name / Nom du modèle / Modellnamn  
 Nome modello / Název modelu / Modelnaam / lme modela  
 Numéro Modelo / Modell neve / Название модели /  
 Názov modelu / lme modela / Denumire model /  
 Наименование на модела / Nazwa modelu

**Synnax**

Modellnummer / Number / Numéro du modèle  
 Numero / Номер на модела / modello  
 Číslo modelu / Modell száma / Èislo modelu  
 Številka modela / Număr model / Broj modela  
 Modelnummer / Numer modelu

2134-310-84

Type / Tipo / Tipus / Typ / Тип / Tip

**310**

LKZ 80236

**D** Unser Direktservice für Beschlagteile  
 Sollte Ihnen ein Beschlagteil fehlen, können Sie diese Servicekarte direkt an die untenstehende Adresse mailen. Wir können allerdings nur Beschlagteile auf diesem Wege verschicken. Sollten Sie eine andere Beanstandung an Ihrem Möbelstück haben, so wenden Sie sich bitte direkt an Ihr Möbelhaus.

**GB** Our direct order service for fitting  
 If a fitting part is missing, you can e-mail this service card directly to the address below. However, we can only send fitting parts in this way. If you have any other cause for complaint concerning your item of furniture, please contact your furniture store directly.

**CZ** Naše přímé služby pro kování  
 Chybí-li vám nějaký díl z kování, můžete tuto servisní kartu odeslat e-mailem přímo na níže uvedenou adresu. Touto cestou však můžeme rozeslat jen díly z kování. Pokud byste reklamovali jiný díl nábytku, obraťte se přímo na svého prodejce nábytku.

**F** Bien étudier la notice de montage  
 S'il vous manque une ferrure, veuillez envoyer directement la présente carte service à l'adresse e-mail indiquée ci-dessous. Cependant, ceci nous permet uniquement d'envoyer des ferrures. Pour tout autre type de réclamation concernant votre meuble, veuillez contacter directement votre magasin d'ameublement.

**I** Il nostro servizio diretto per l'ordine della ferramenta  
 Qualora Vi dovesse mancare un pezzo di fissaggio, allora Vi preghiamo di inviare questa carta di servizio immediatamente all'indirizzo sottostante. Possiamo inviare i pezzi di fissaggio solamente per mezzo di questo procedimento. Qualora dovete avere qualche altra reclamazione in merito al mobile, allora Vi preghiamo di rivolgerVi direttamente al Vostro Negozio di mobili.

**BG** Нашата директна услуга за обков  
 Ако липсват части от комплекта, попълнете настоящата сервисна карта и ни я изпратете на e-mail адреса, посочен по-долу. По този начин можем да доставяме само липсващи елементи от обкова. Ако установите други дефекти по мебелите, Ви съветваме да се обърнете към мебелната къща/магазин, от който сте закупили стоката.

**NL** Onze directservice voor losse onderdelen  
 Wanneer er een onderdeel ontbreekt, kunt u deze servicekaart direct aan onderstaand e-mailadres sturen. Wij kunnen langs deze weg echter alleen beslagdelen versturen. Mocht u een ander probleem aan uw meubel hebben, verzoekten wij u contact op te nemen met uw meubeldealer.

**PL** Nasz bezpośredni serwis części montazowych  
 Jeżeli brakuje części koniecznych do montażu, prosimy o przesłanie nam niniejszej karty serwisowej na niżej podany adres e-mailowy. W ten sposób możemy przesłać Państwu tylko brakujące części. W przypadku innych reklamacji dotyczących mebla, prosimy zgłosić się do salonu meblowego, w którym został dokonany zakup.

**HR** Servis za okove  
 U slučaju da nedostaje neki od dijelova molimo vas da na dolje navedenu mail adresu pošaljete ovaj servisni obrazac. Na ovaj način mogu se dostaviti samo okovi. U slučaju da imate dodatne prigovore vezane uz komad namještaja molimo vas da se obratite izravno trgovini namještaja gdje je isti kupljen.

**HU** Direktszolgáltatunk vasalatók esetén  
 Ha hiányzik egy vasalat, ezt a kártyát közvetlenül elküldheti az alább található címre. Azonban csakis vasalatókat tudunk így küldeni. Ezenyíven másfajta reklamáció áll fenn bútordarabját illetően, forduljon közvetlenül a bútortházhoz.

**SK** Naš priamy servis pre časti kovania  
 Ak by Vám chýbala nejaká časť kovania, môžete poslať túto servisnú kartu poslať e-mailom na nižšie uvedenú adresu. Diely kovania vieme poslať iba týmto spôsobom. Ak by ste mali inú reklamáciu oľhadom Vášho nábytku, obráťte sa priamo na Vašu predajňu nábytku.

**SLO** Naše direktno uslužne storitve za okovje  
 Če vam manjka kakšno okovje, lahko to servisno kartico pošljete po e-pošti direktno na spodnji naslov. Po tej poti vam lahko pošljemo samo okovje. Če želite reklamirati kakšen drug del pohištva, se obrnite neposredno na vašo trgovino pohištva.

**RO** Service-ul nostru direct pentru feronerie  
 În cazul în care vă lipsește o piesă de feronerie puteți să trimiteți direct acest card de service prin e-mail la adresa de mai jos. Noi nu putem expedia piese de feronerie decât pe această cale. Dacă aveți o altă reclamație referitoare la piesa de mobilier, atunci vă rugăm să vă adresați direct la magazinul dvs. de mobilă.

**RUS** Наш прямой сервис для поставок фурнитуры  
 Если окажется, что Вам не хватает того или иного элемента фурнитуры, Вы можете отправить сервисную карту по факсу непосредственно на нижеприведенный адрес электронной почты. Однако, таким образом мы можем пересылать лишь фурнитуру. Если же у Вас возникнут иные претензии относительно приобретенной мебели, пожалуйста, обращайтесь непосредственно в организацию, осуществившую продажу.

**S** Vår direktservice för beslagsdelar  
 Om du saknar en beslagsdel kan du skicka detta servicekort direkt till e-postadressen som anges nedan. Tänk på att detta är den enda möjligheten att skicka beslagsdelar till dig. Om du vill reklamera din möbel av en annan anledning måste du kontakta ditt möbelhus direkt.

**ES** Nuestro servicio directo para accesorios  
 Si le falta algún accesorio, puede enviar esta tarjeta de servicio directamente a la siguiente dirección. No obstante, por este método solo podemos enviar accesorios. Si tiene alguna otra objeción sobre su mueble, consulte directamente con su mueblería.

**TR** Donatılar için doğrudan servisimiz  
 Bir donatınız eksikse bu servis kartını doğrudan aşağıda bulunan adrese doğrudan mail yazabilirsiniz. Sadece bu yolla donatılar gönderilebilir. Mobilyanızda başka şikayetleriniz varsa lütfen doğrudan mobilya satıcınıza danışın.

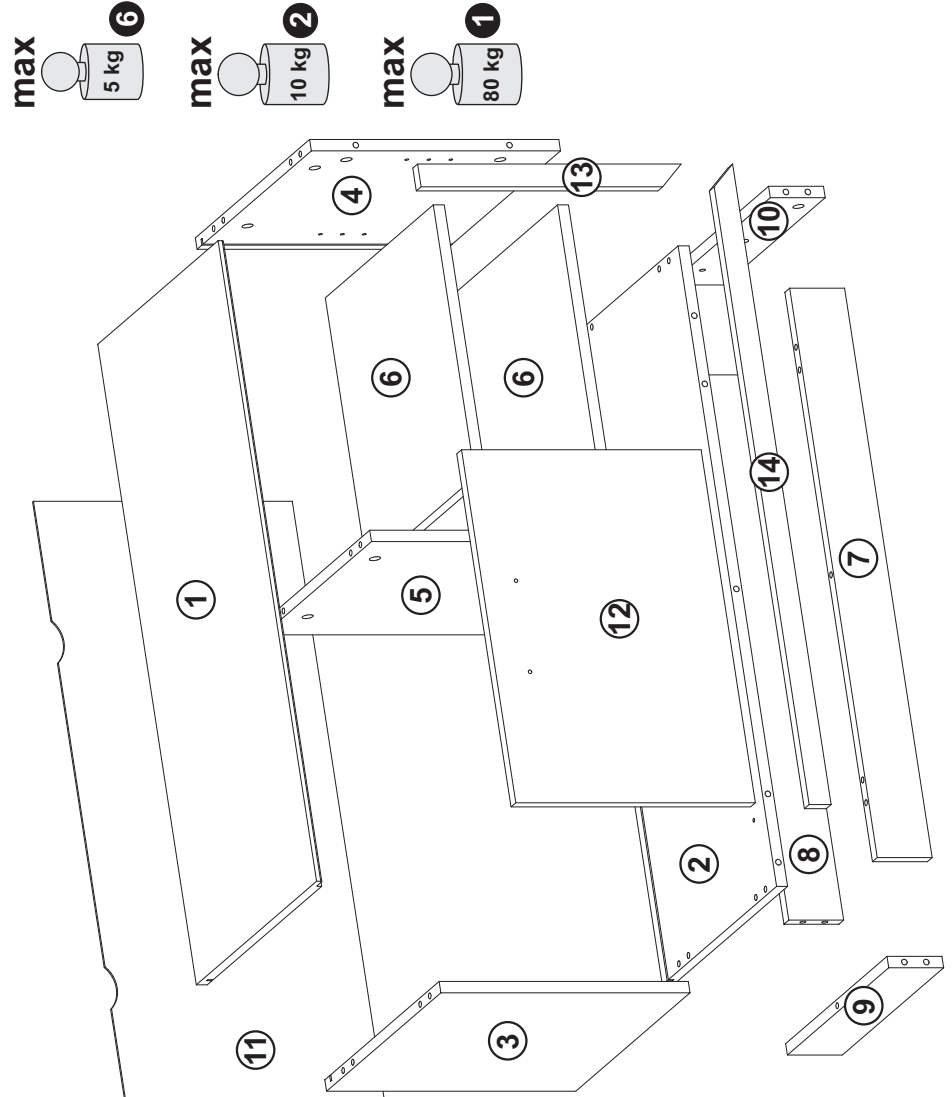

1	2	3	4	5	6	7	8	9	10	11	12	13	14		
900	400	380	380	380	360	359	80	766	80	337	337	377	496	384	900
1/1	16 x1	16 x1	16 x1	16 x1	16 x1	16 x2	16 x1	16 x1	16 x1	16 x1	16 x1	3 x1	16 x1	16 x1	16 x1

Grund der Beanstandung / Cause for complaint:

---

Möbelhaus / Furniture store:

---

Kunde / Customer: Telefon / Telephone:

---

PLZ / Postcode: Ort / City:

---

Str.+Nr. / Street address

---

@E-Mail:

LKZ 80236

Modellname / Model name / Nom du modèle / Modellnamn  
Nome modello / Název modelu / Modelnaam / Ime modela  
Número Modelo / Modell neve / Название модели /  
Názov modelu / Ime modela / Denumire model /  
Наименование на модели / Nazwa modelu

**SynnaX**











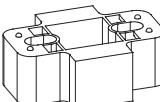
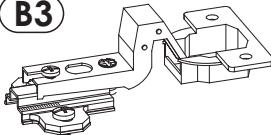

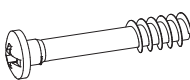
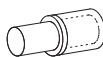

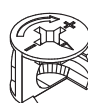
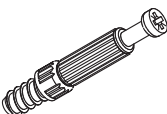
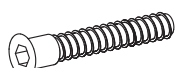
Modellnummer / Number / Numéro du modèle  
Numero / Номер на модели / modello  
Číslo modelu / Modell száma / Ěíslo modelu  
Številka modela / Număr model / Broj modela  
Modellnummer / Numer modelu

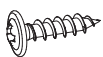
2134-310-84

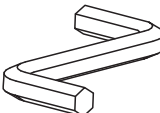
Type / Tipo / Tipus / Typ / Тип / Tip

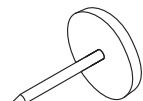
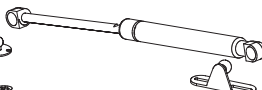
**310**

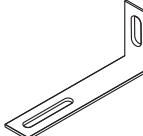
## B1 Colli 1/1

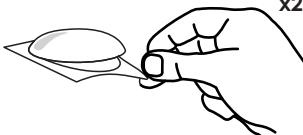
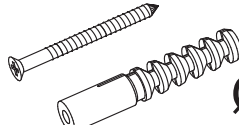
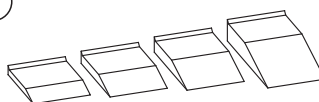
<b>A1</b> 8 x 35 mm x22 	<b>B4B</b>  x2	<b>B0 + B3</b>  x2
<b>C2</b> 5x13 mm x4 	<b>C12</b> 6,3 x 33 x4 	<b>D2</b>  x4
<b>E0</b>  x8	<b>E1</b> 15 x 12,5 mm x23 	<b>F1</b>  x23
<b>G1</b> 7 x 50 mm x6 	<b>H1</b> L-180 mm x1 	<b>I2</b> 4 x 16 mm x2 
<b>I5</b> 3,5 x 27 mm x2 	<b>M</b>  x1	<b>N1</b> 3 x 16 mm x5 
<b>O2</b>  x8	<b>PB</b>  x1 	<b>Q9</b>  x2
<b>R4</b>  x6	<b>R8</b>  x2	<b>S13</b>  x2 Ø8
		<b>Z</b>  x1

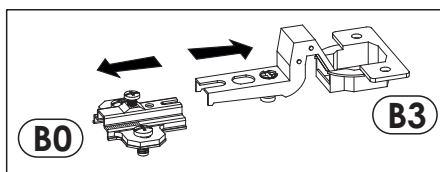
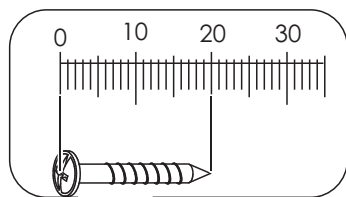

1

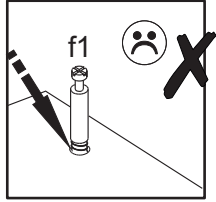
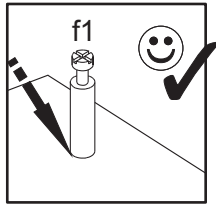
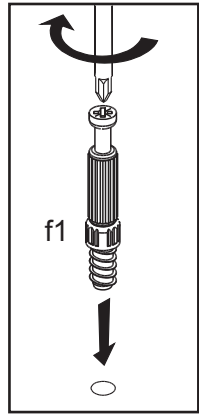
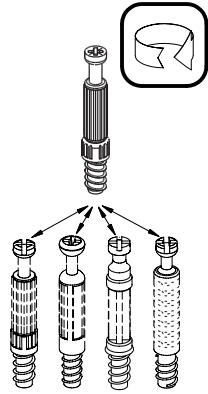
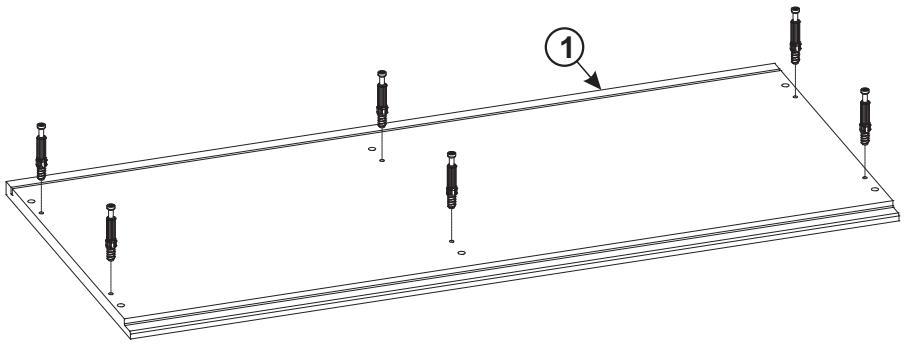
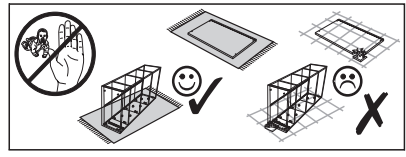
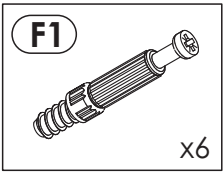

2

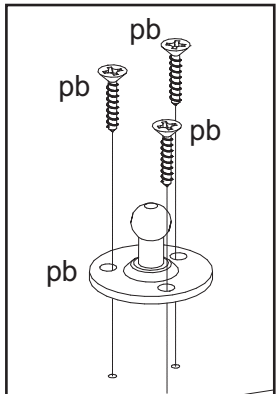
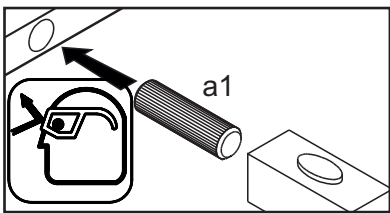
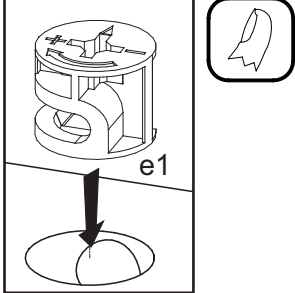
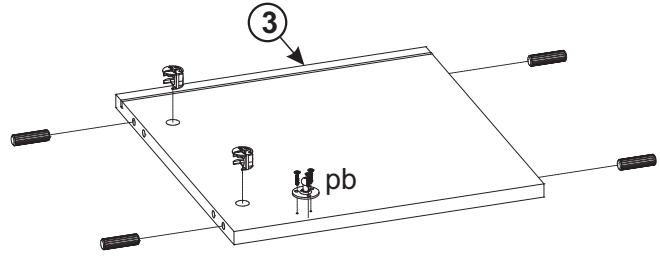
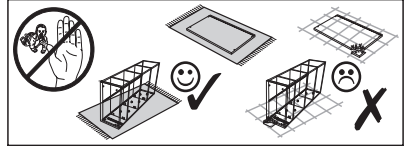
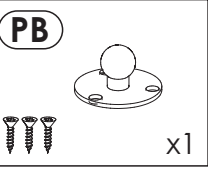
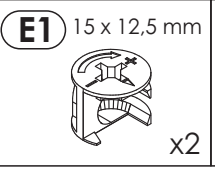
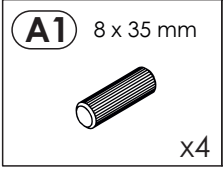

3

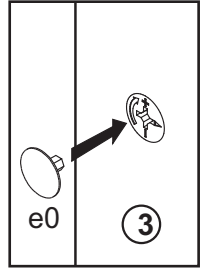
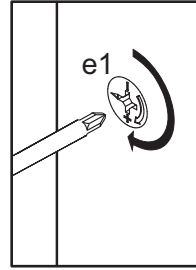
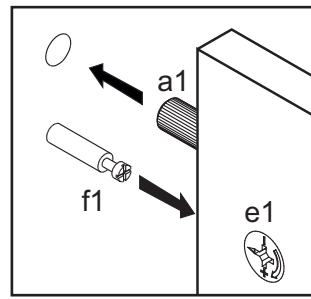
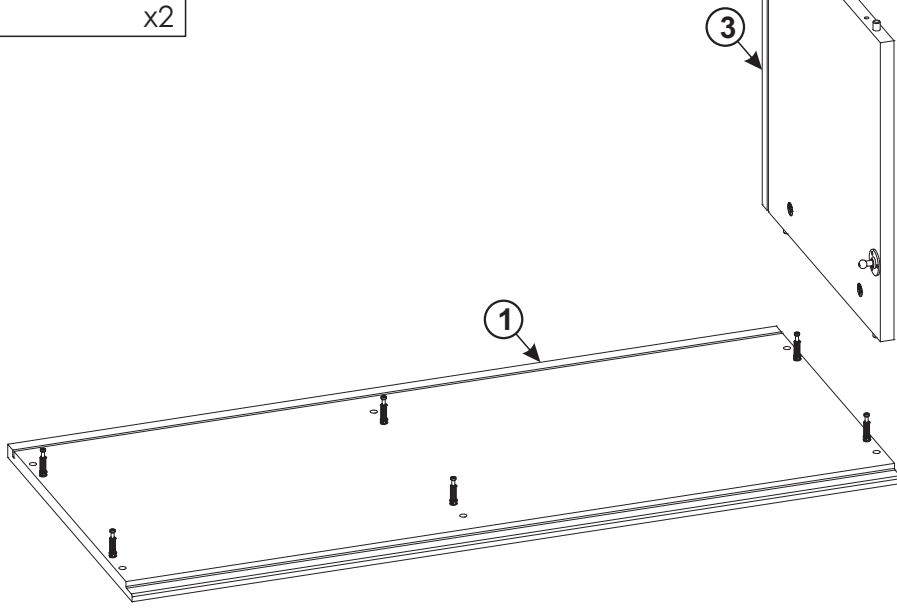
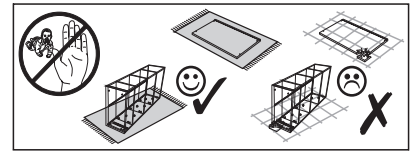
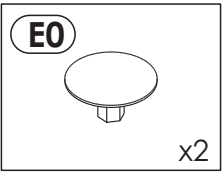

4

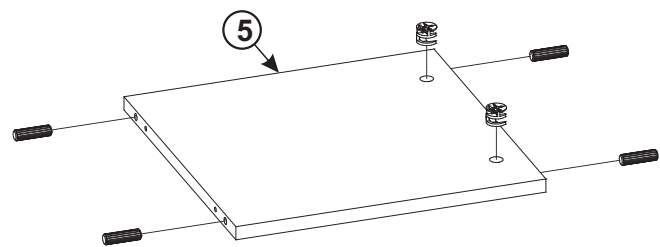
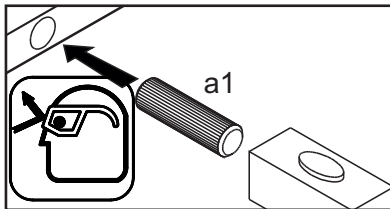
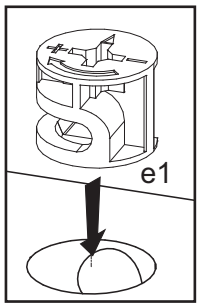
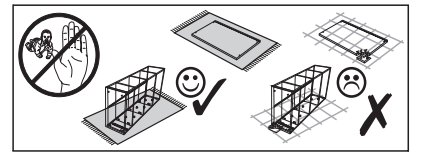
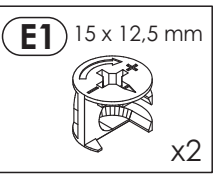
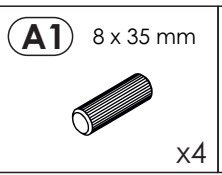



5

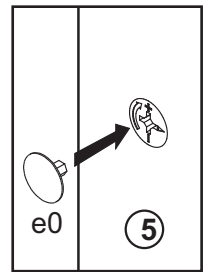
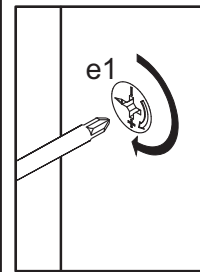
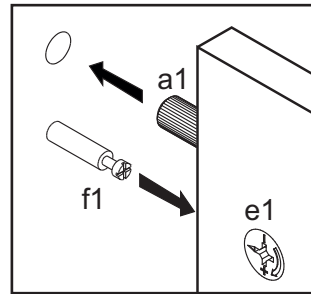
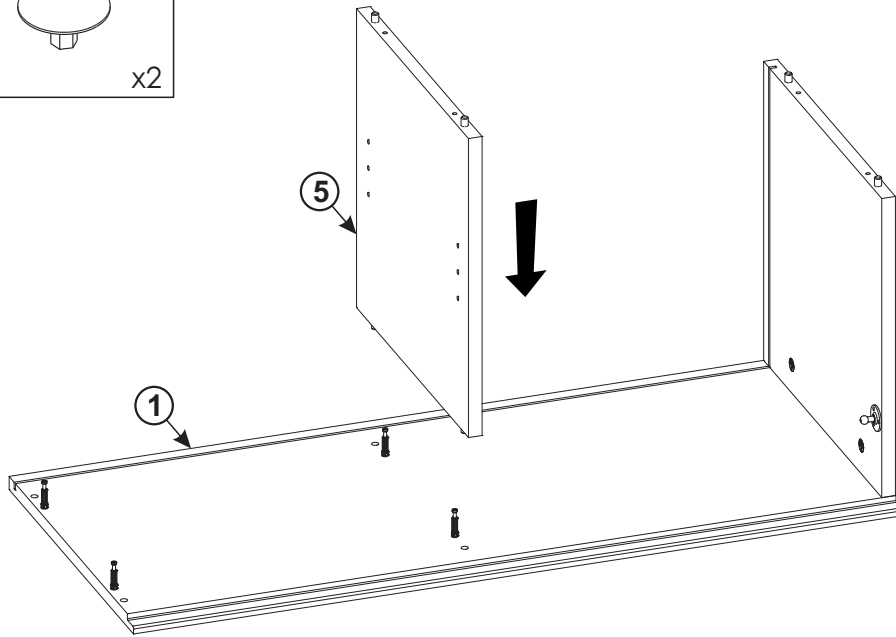
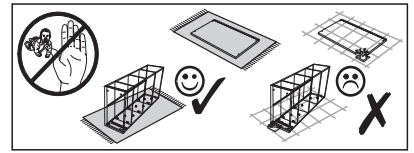
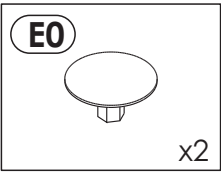

6

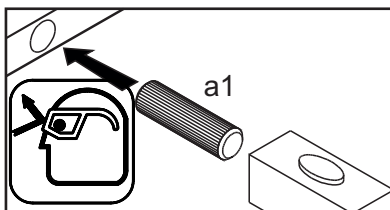
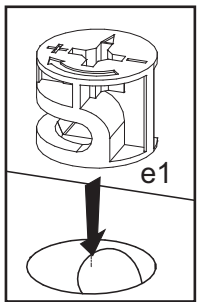
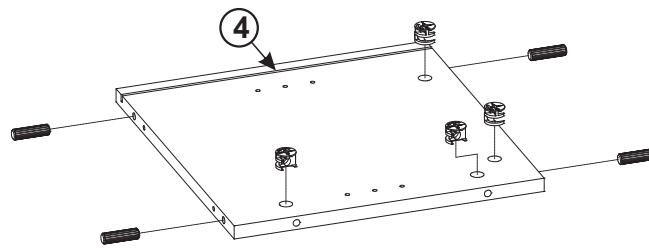
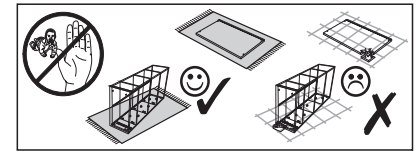
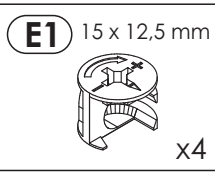
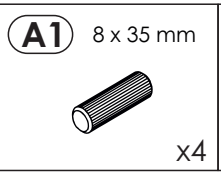

7

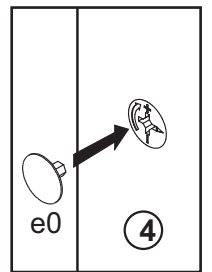
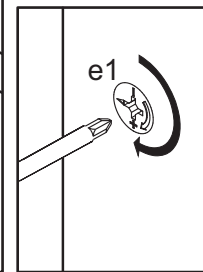
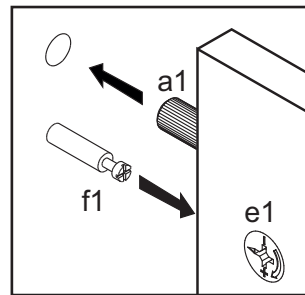
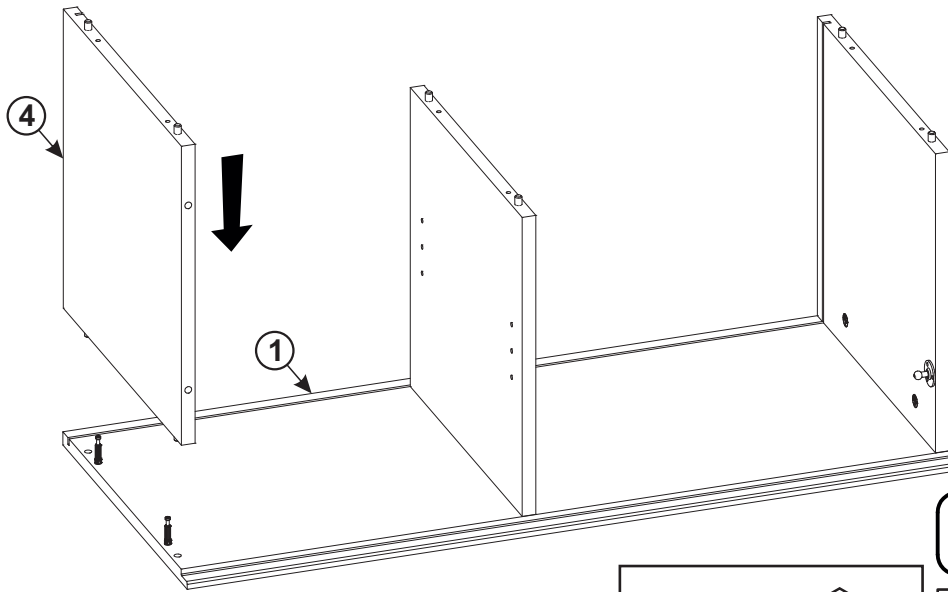
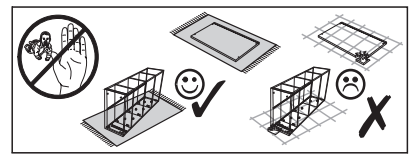
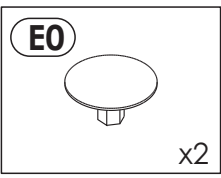

8

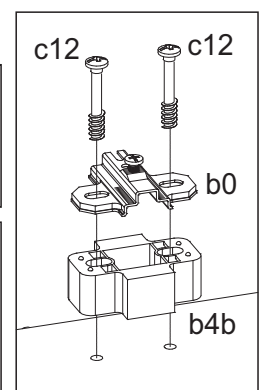
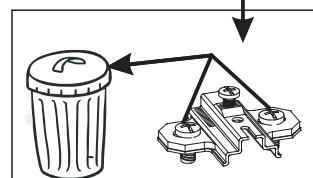
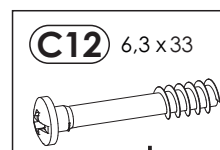
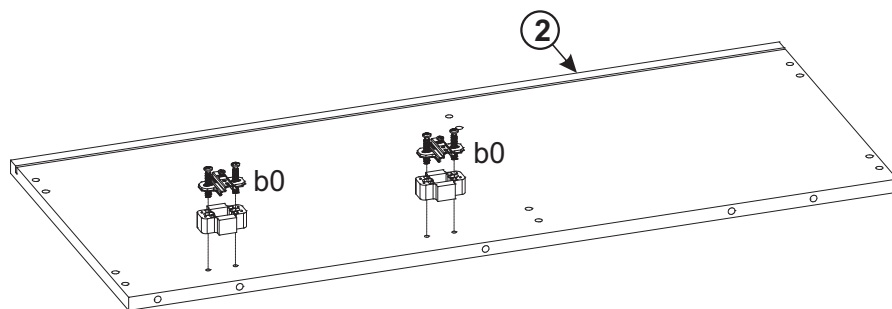
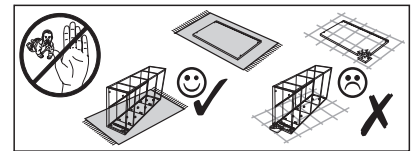
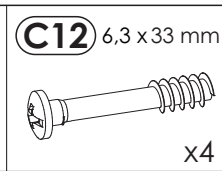
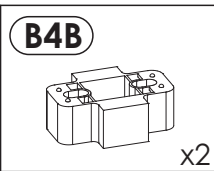
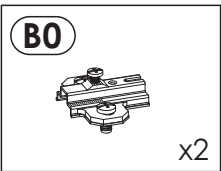

9

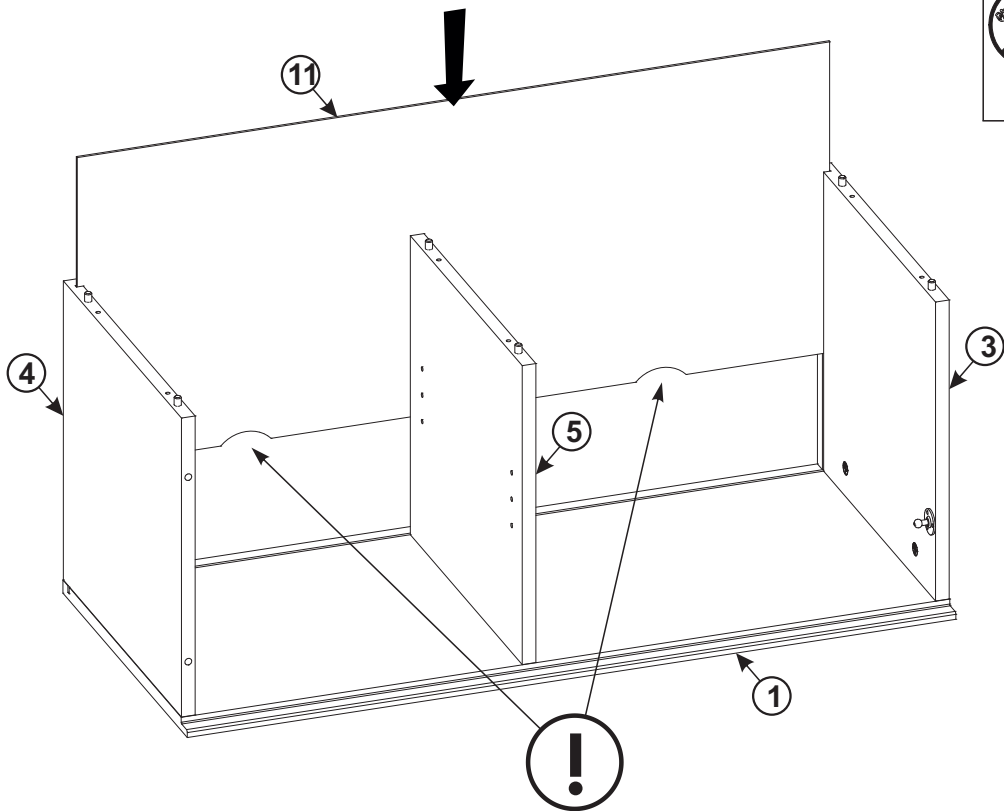

10

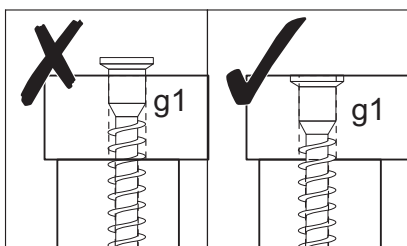
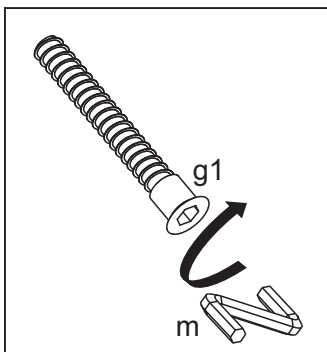
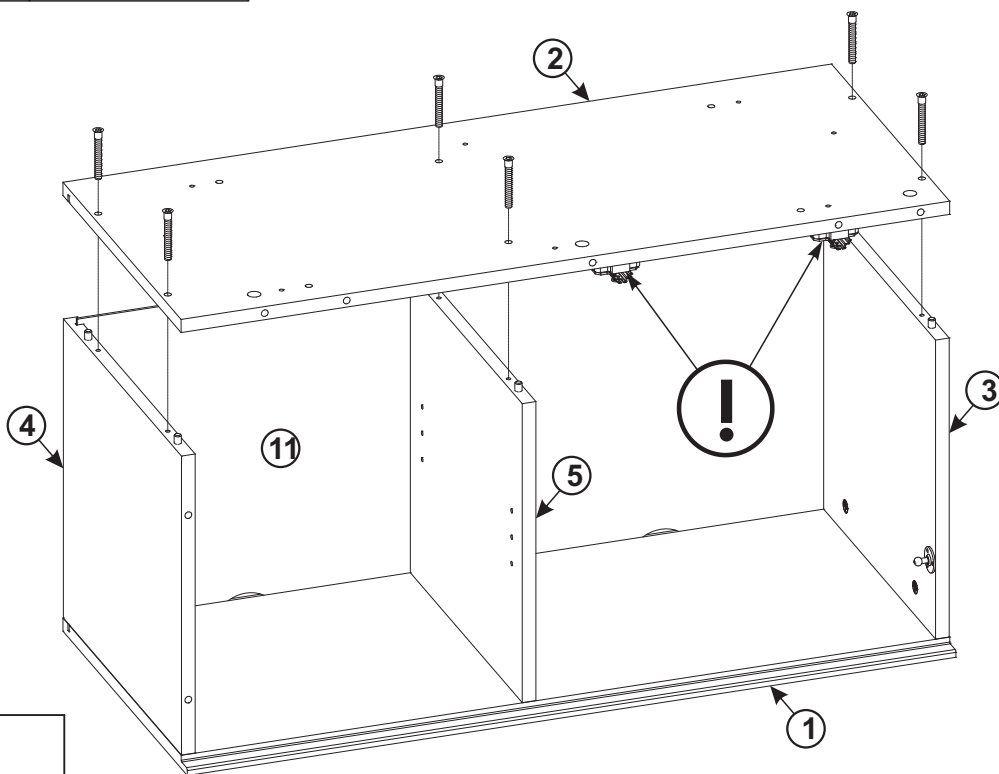
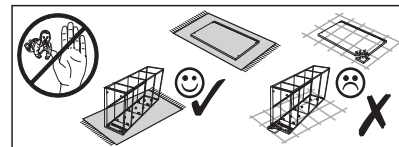
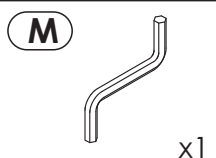
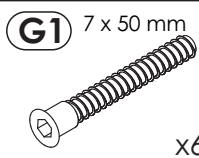

11

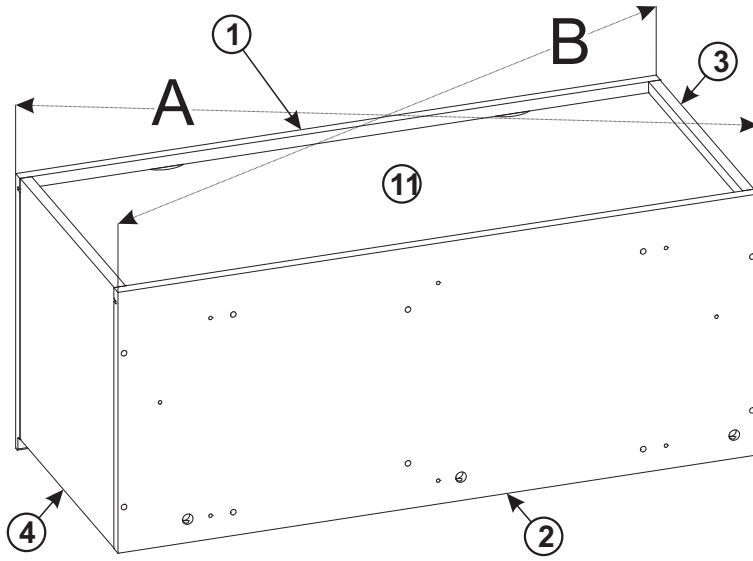
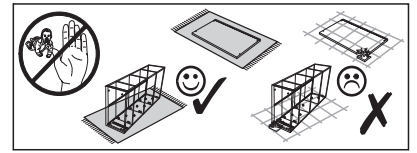

A=B

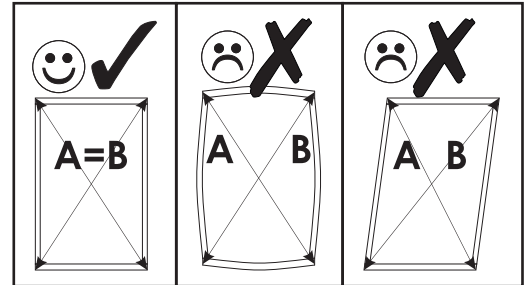

12

**N1** 3 x 16 mm **R4**

x3 x6

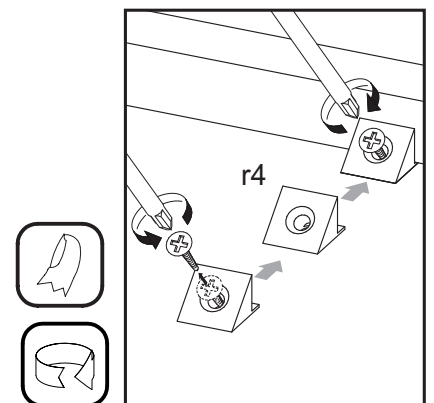
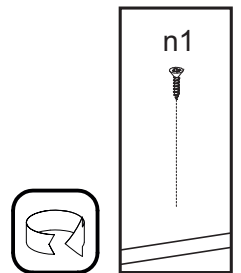
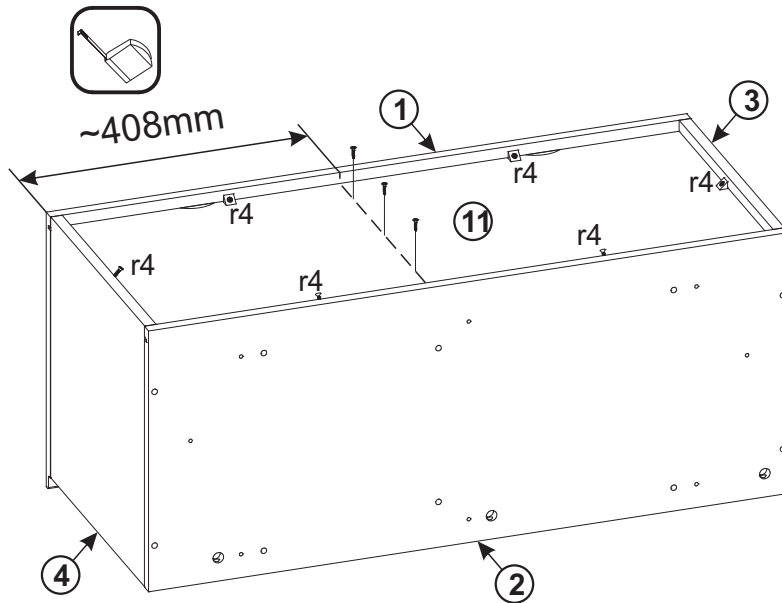
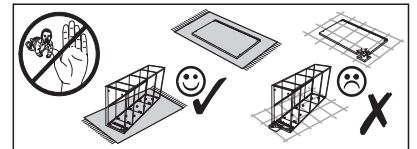

13

A1 8 x 35 mm



x2

E1 15 x 12,5 mm



x3

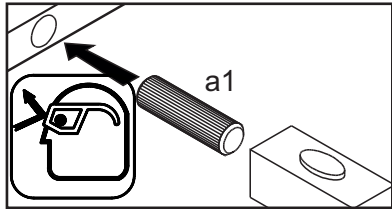
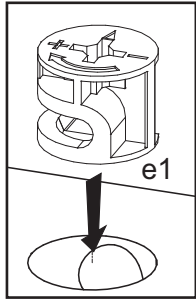
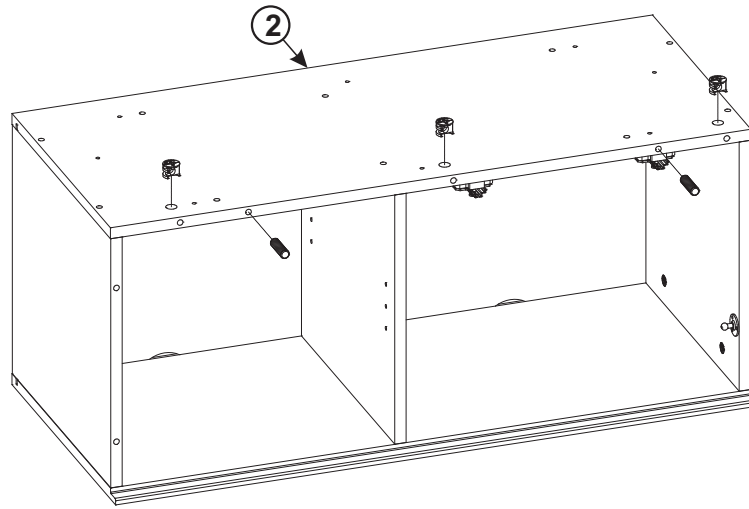
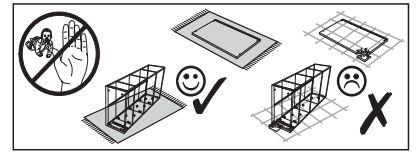

14

F1

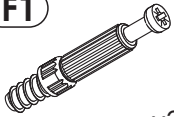

x3

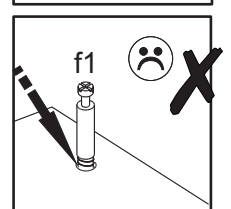
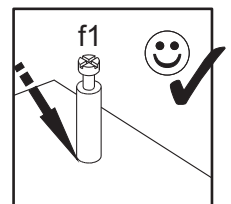
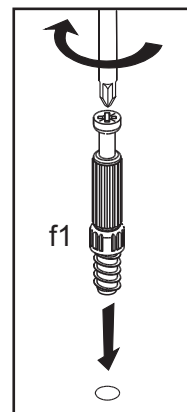
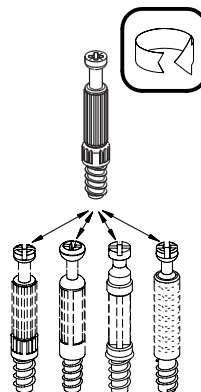
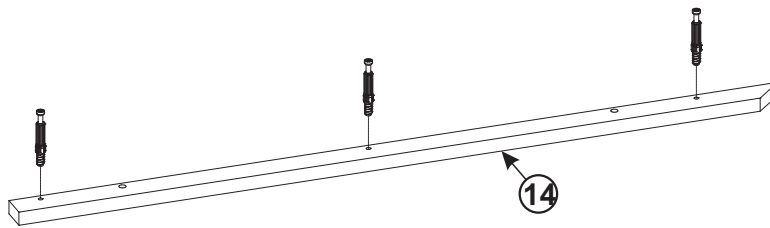
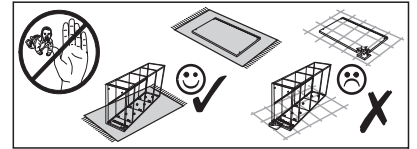

15

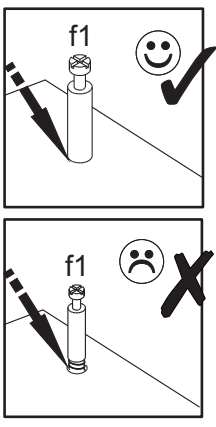
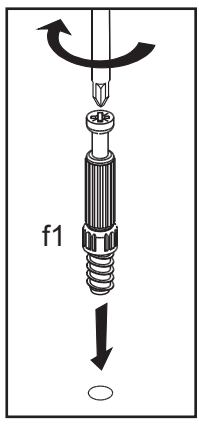
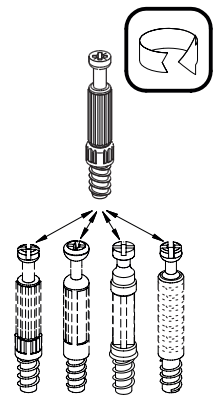
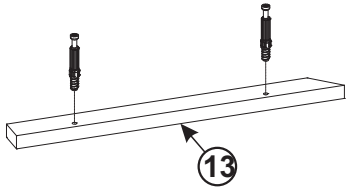
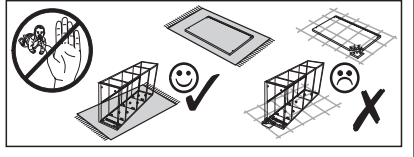
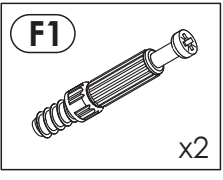

16

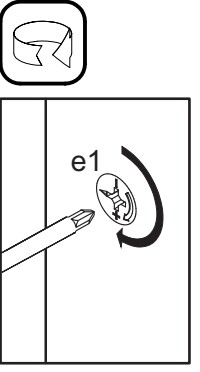
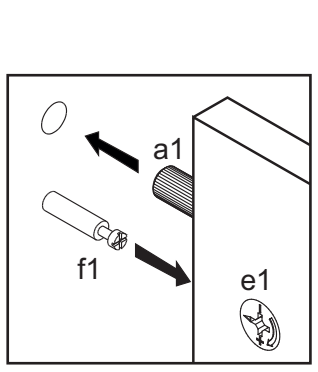
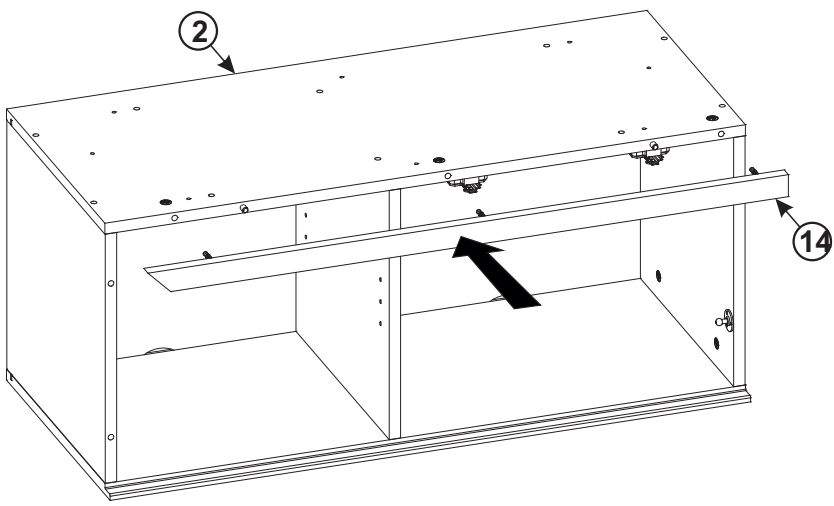
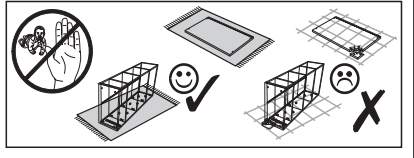

17

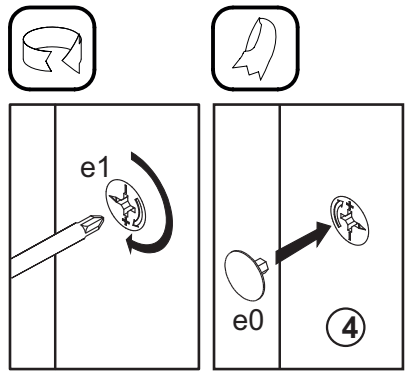
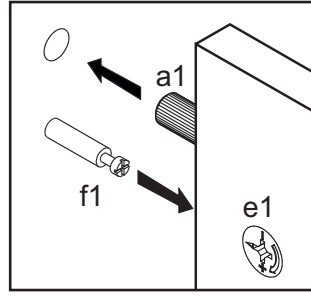
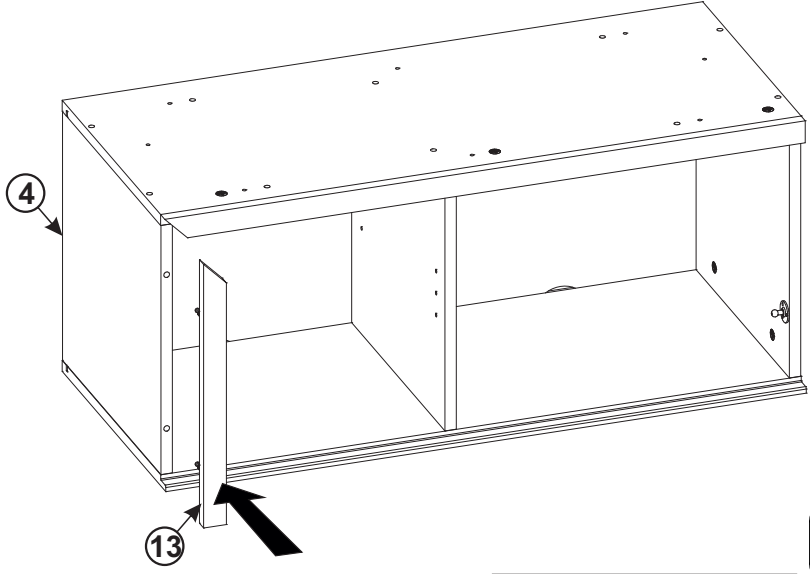
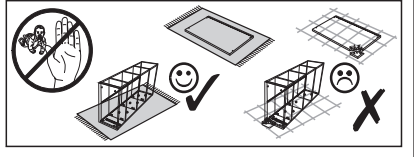
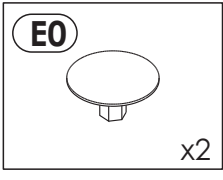

18

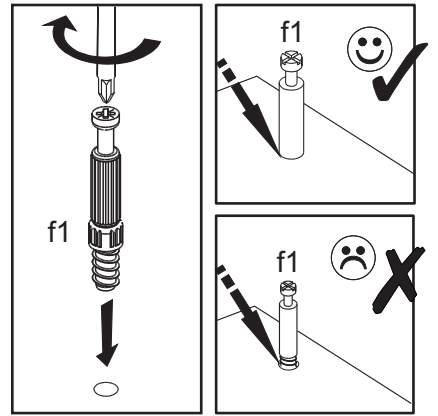
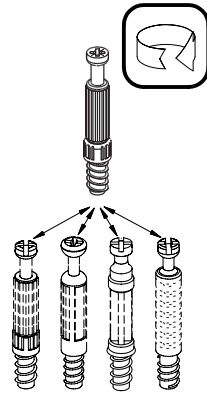
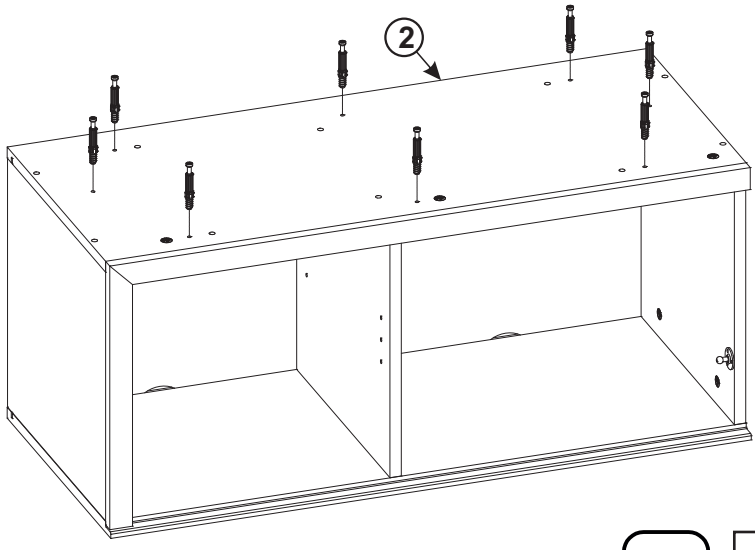
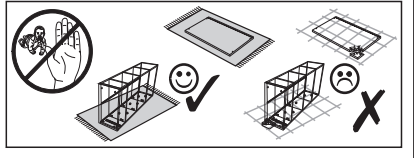
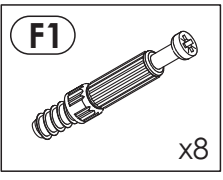

19

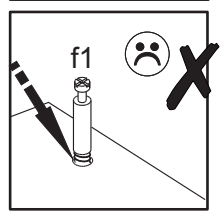
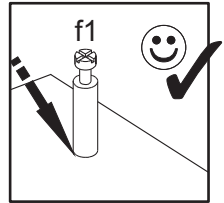
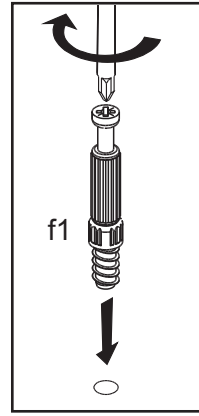
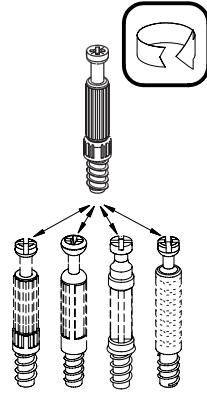
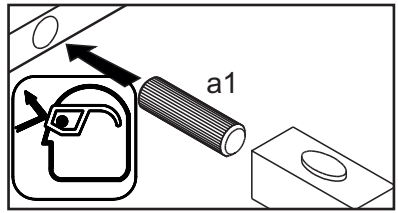
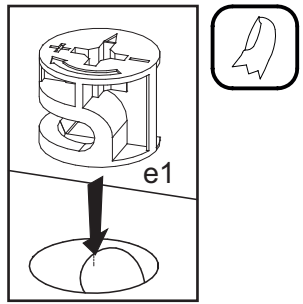
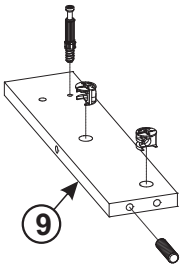
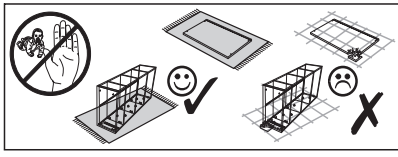
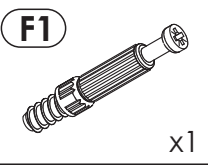
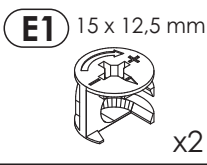
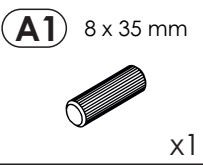

20

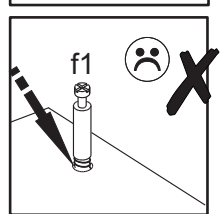
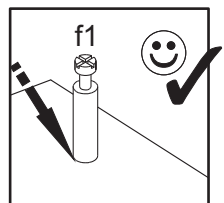
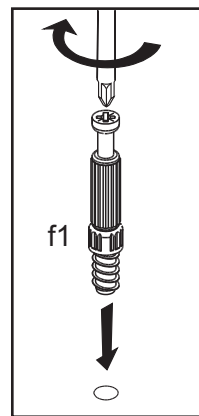
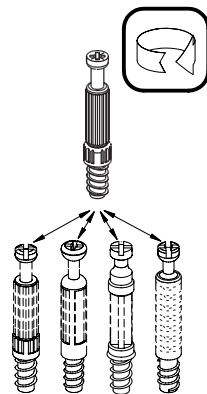
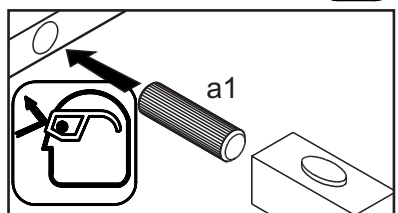
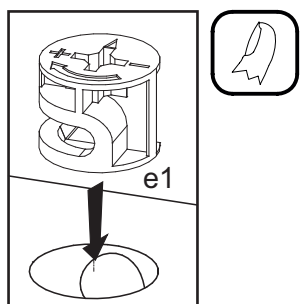
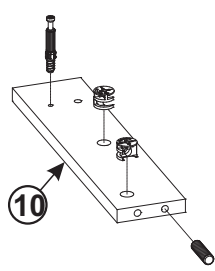
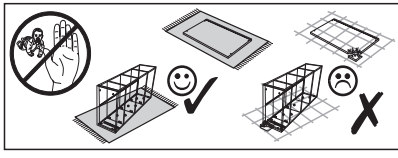
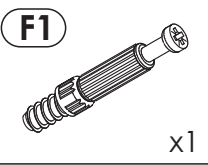
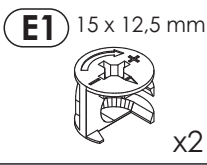
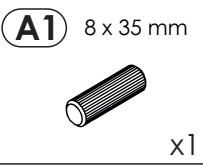



21

**A1** 8 x 35 mm



x4

**E1** 15 x 12,5 mm



x5

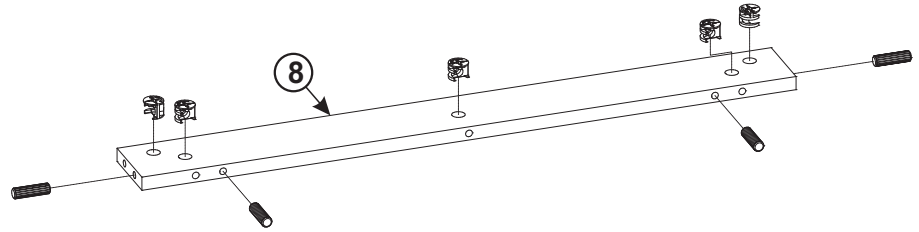
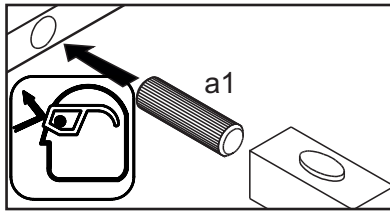
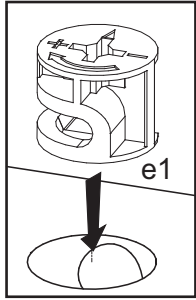
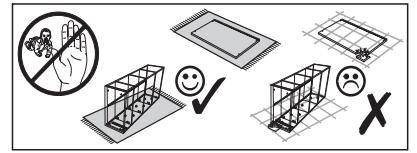

22

**A1** 8 x 35 mm



x2

**E1** 15 x 12,5 mm



x3

**F1**

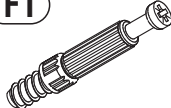

x2

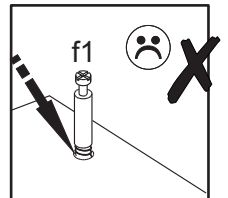
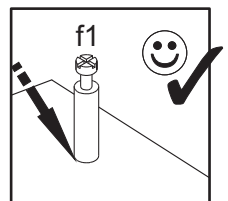
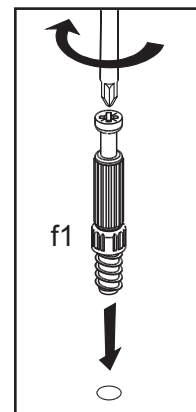
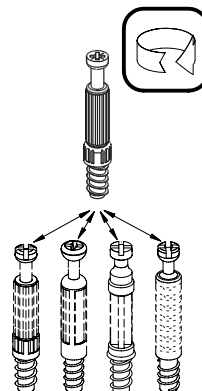
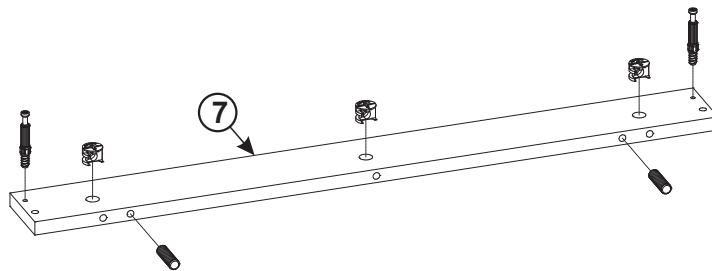
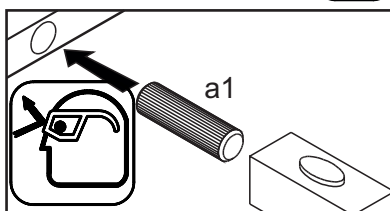
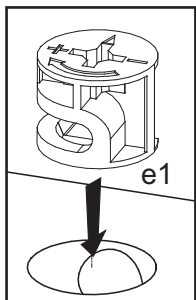
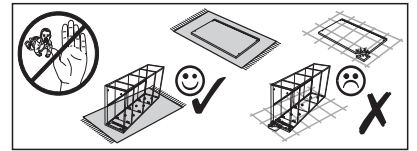

23

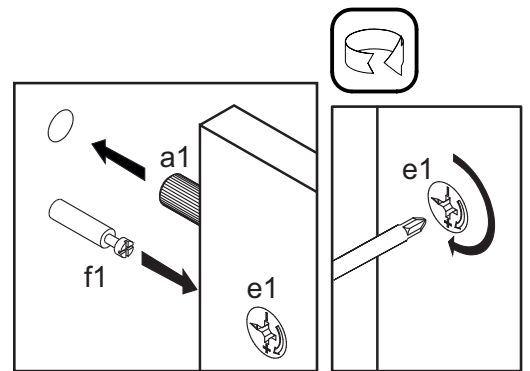
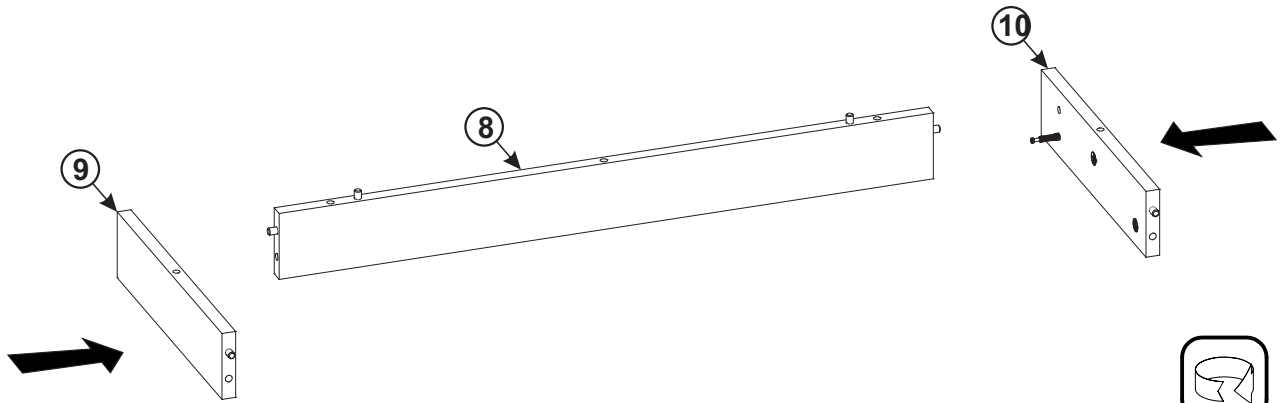
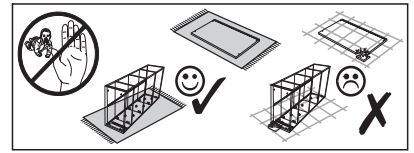

24

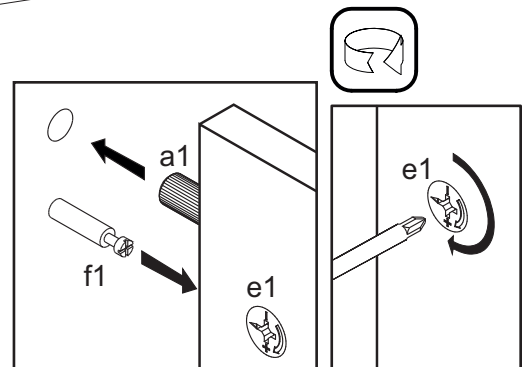
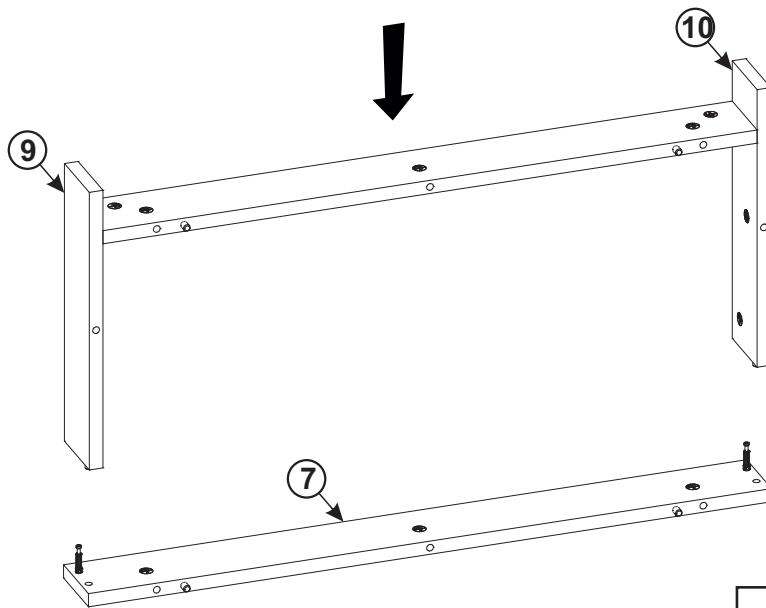
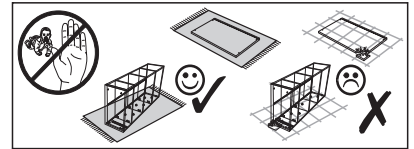

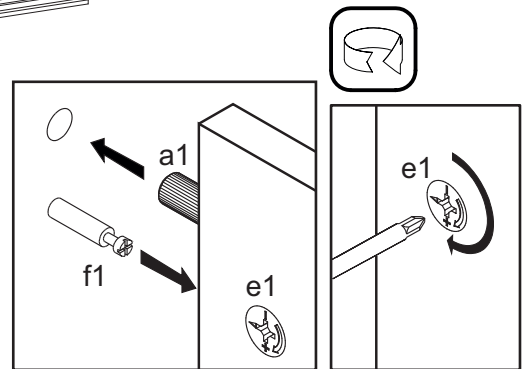
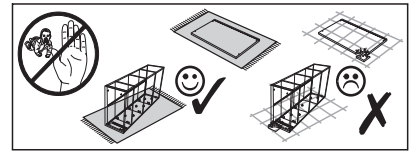
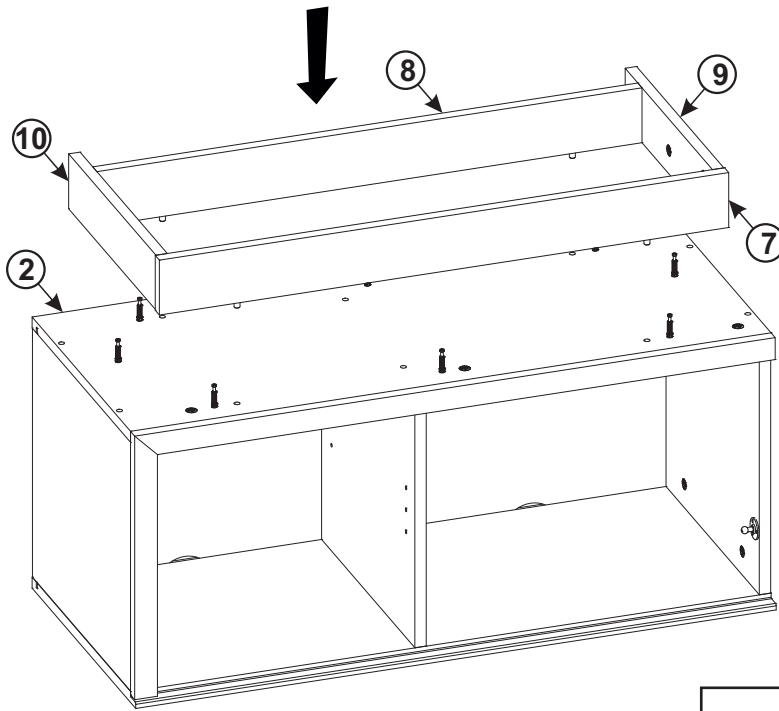

25

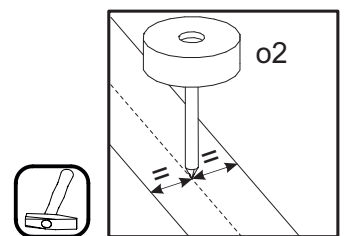
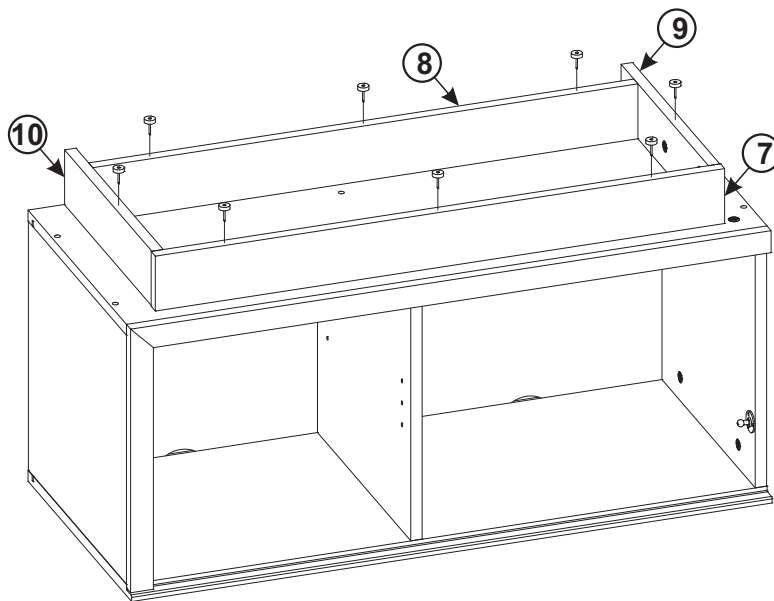
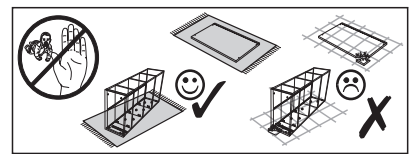
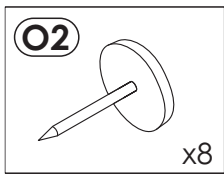

26

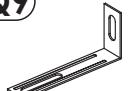

27

<p><b>I2</b> 4x16 mm</p>  <p>x2</p>	<p><b>Q9</b></p>  <p>x2</p>	<p><b>S13</b></p>  <p>Ø8 x2</p>	<p><b>Z</b></p>  <p>x1</p>
---------------------------------------------------------------------------------------------------------------------	-------------------------------------------------------------------------------------------------------------	-----------------------------------------------------------------------------------------------------------------	-------------------------------------------------------------------------------------------------------------

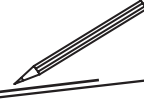
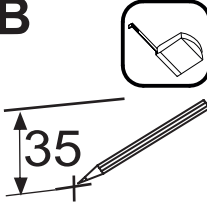
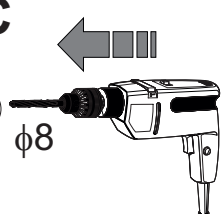
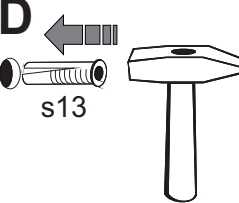
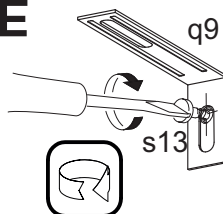
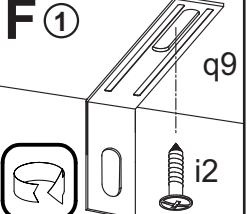
<p><b>A</b></p>  <p>①</p>	<p><b>B</b></p>  <p>35</p>	<p><b>C</b></p>  <p>φ8</p>	<p><b>D</b></p>  <p>s13</p>	<p><b>E</b></p>  <p>q9</p> <p>s13</p>	<p><b>F ①</b></p>  <p>q9</p> <p>i2</p>
------------------------------------------------------------------------------------------------------------	-------------------------------------------------------------------------------------------------------------	-------------------------------------------------------------------------------------------------------------	---------------------------------------------------------------------------------------------------------------	--------------------------------------------------------------------------------------------------------------------------	---------------------------------------------------------------------------------------------------------------------------

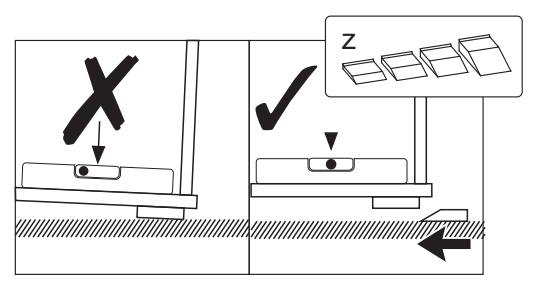
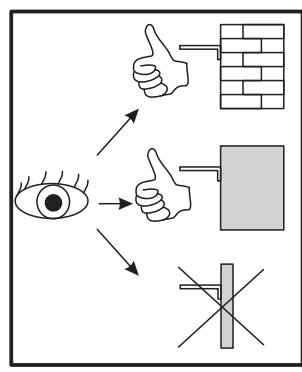
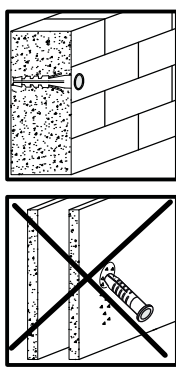
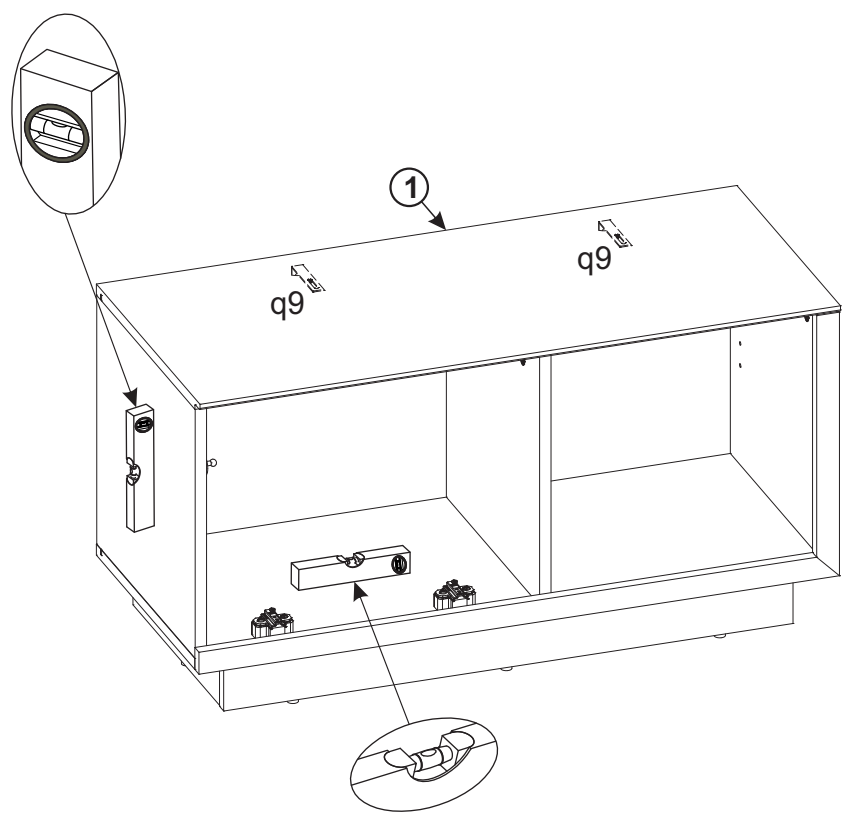

28

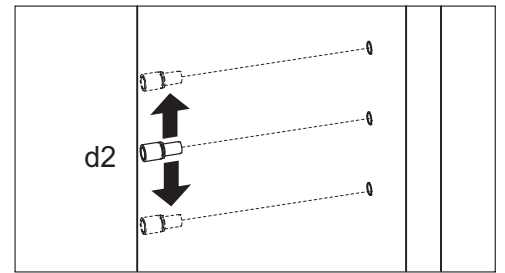
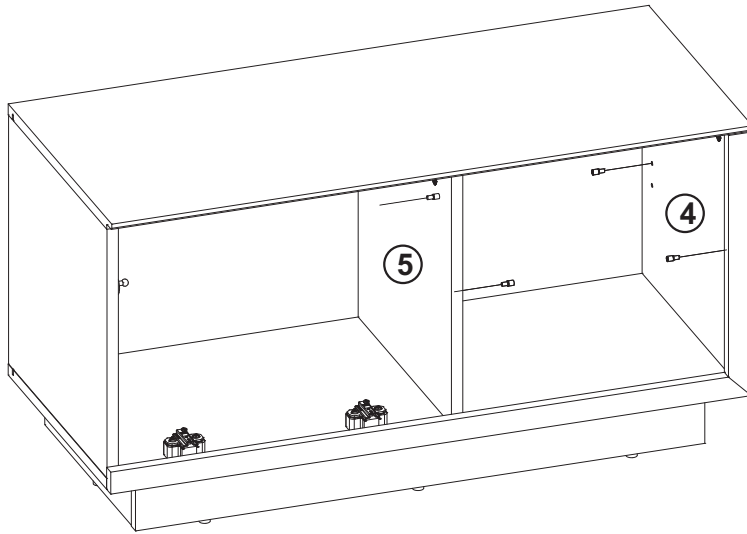
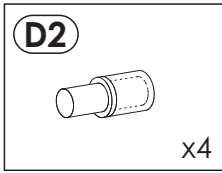

29

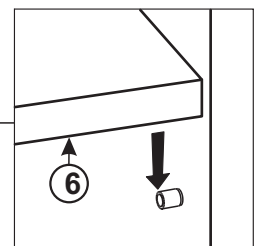
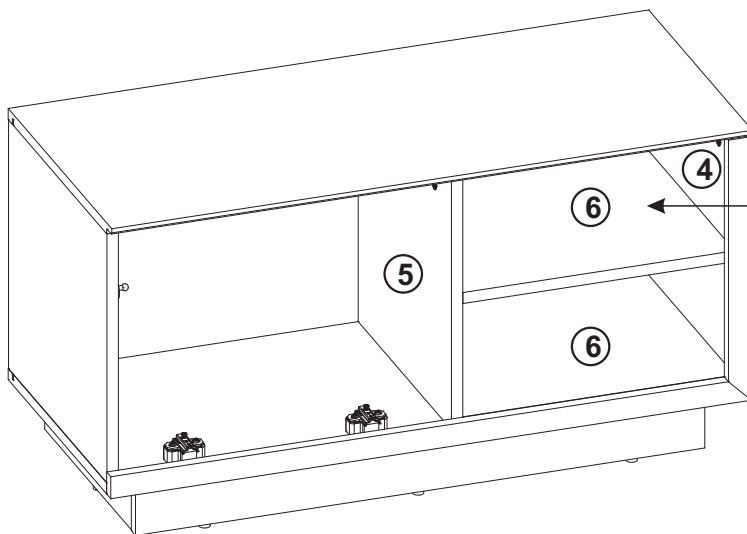

30

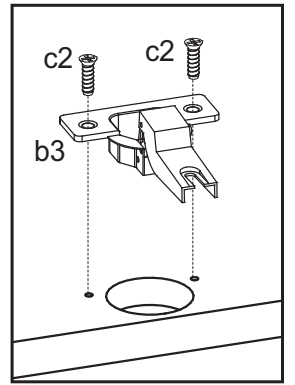
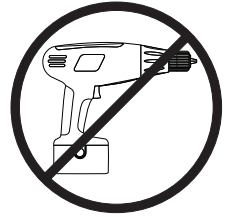
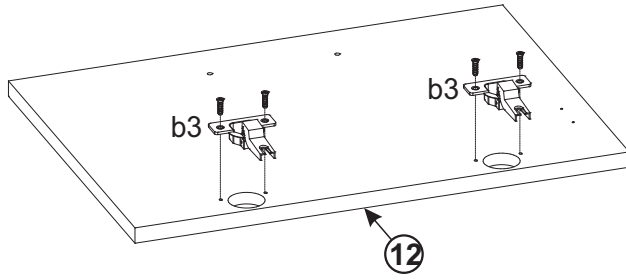
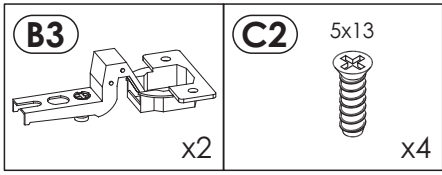

31

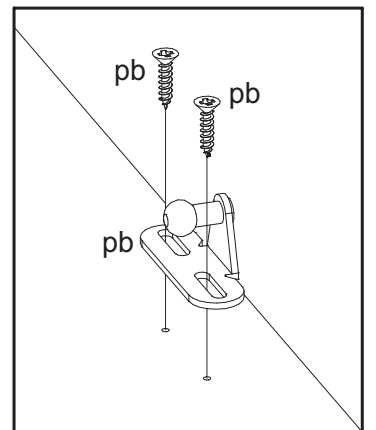
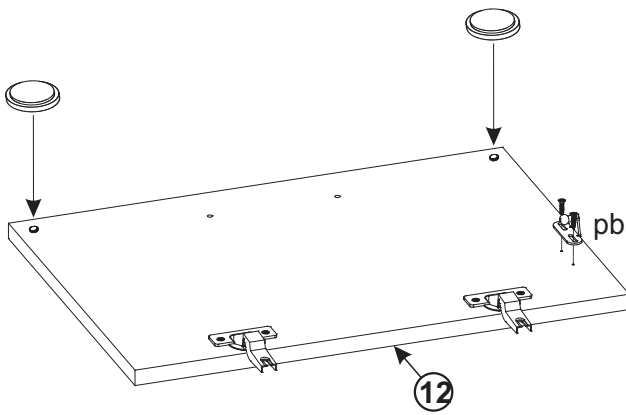
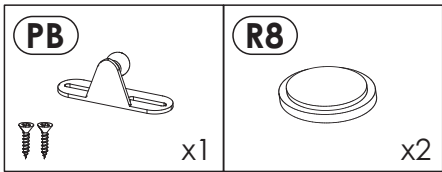

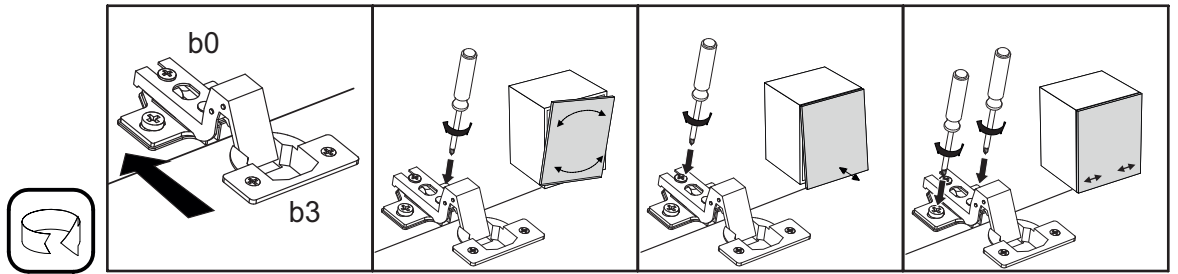
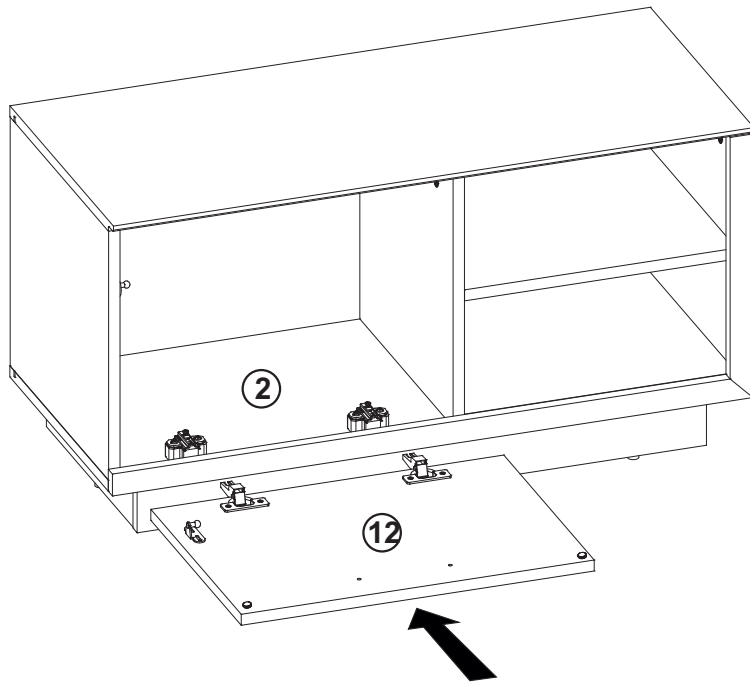

32

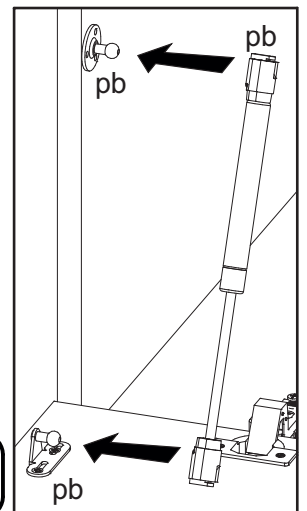
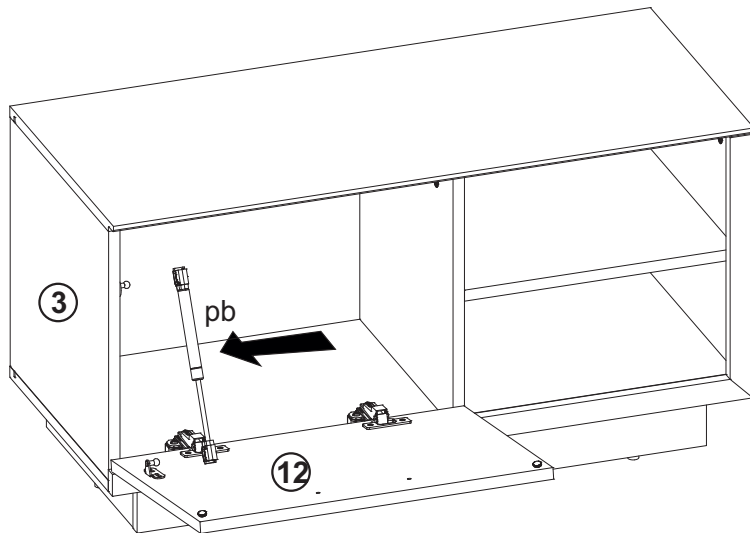
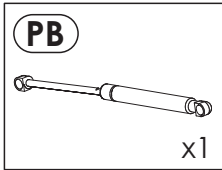

33



34

<b>H1</b> L-180  x1	<b>I5</b> 3,5 x 27  x2
------------------------------------------------------------------------------------------------------------	---------------------------------------------------------------------------------------------------------------

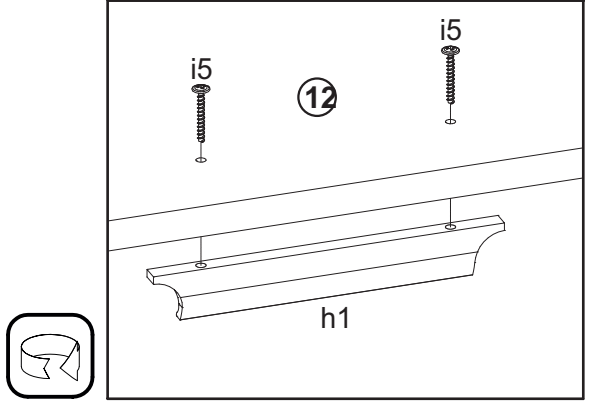
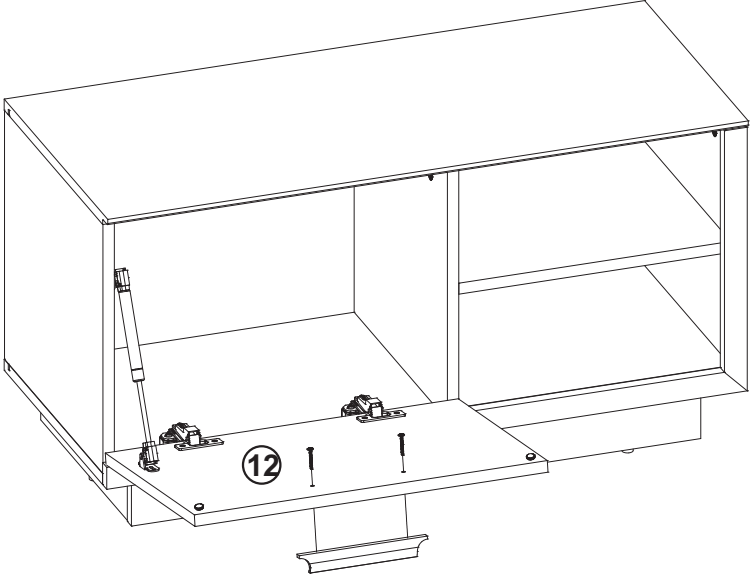



LKZ 80236

Modellname / Model name / Nom du modèle / Modellnamn / Nome modello / Název modelu / Modelnaam / Ime modela / Numéro Modelo / Modell neve / Название модели / Názov modelu / Ime modela / Denumire model / Наименование на модела / Nazwa modelu

**Synnax**

Modellnummer / Number / Numéro du modèle / Numero / Номер на модела / modello / Číslo modelu / Modell száma / Éislo modelu / Številka modela / Număr model / Broj modela / Modelnummer / Numer modelu

**2134-442-51**

Type / Tipo / Tipus / Тип / Тип / Tip

**442**

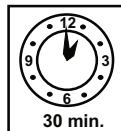
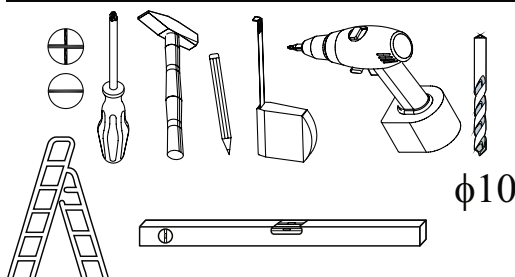
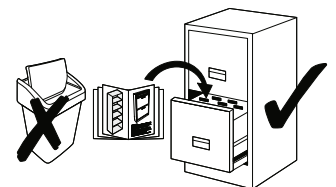
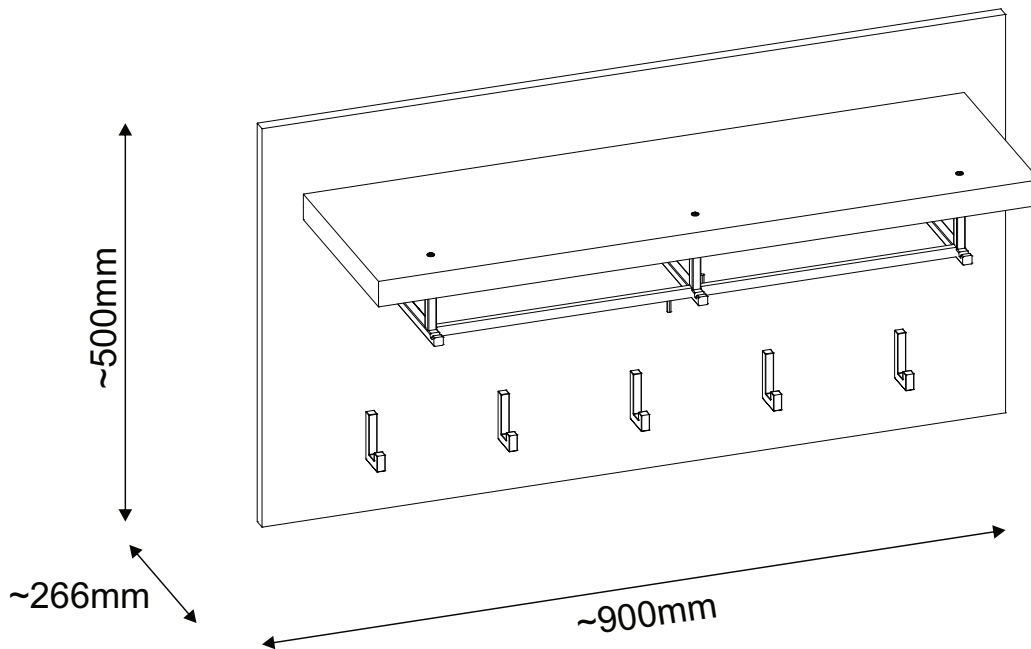
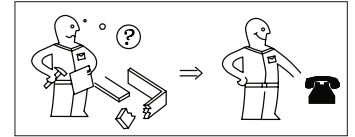
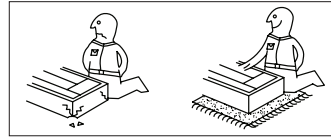
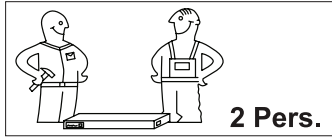
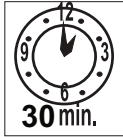

festziehen / tighten / Затягнэне / serrer / stringere / utåhnout / vasttrekken / zategnuti / strångere / zwiázac / zacisnåç / szorosan meghúzni / pevne dotiahnut / trdno pritegniti / затянуть / dra át



eindrücken / press in / enfoncer / wcisnåç / ribattere / zatlaçit / Вкарайте / indrukken / benyomni / stlaçit / vtisniti / tryck in / introducere prin apåsare / вдавить



ausmessen / measure / mesurer / misurare / opmeten / izmeriti / miara / kimérni / izmeriti / måsurare / измерить / změřit / Измерете / måt upp / zmierzyc



drücken / press / presser / stisknout / Натиснэне / vtisniti / nasinac / drukken / pritisnuti / nacinac / pritisniti / нажатъ / (meg)nyomni / apåsare / tryck fast / nacinåç



einschlagen / hammer in / beverni / sla in / frapper au marteau / infossare / Zabit / zarazit / Набийте / zabiti / wbiç / introducere prin båtaie / забить / zatlout



Drehen - wenden / przekræciç - odwróciç / Keren - omdraaien / Girare - Ruotare / Okrenuti - ubrtuti / Retourner - renverser / Turn over - turn around / Otoçte - obratite / Завъртете - обърнэне / Obrnite list / Introarçei - rotii / Vrid runt - vånd / прокрутить - повернуть / otoçit - obråtit / elforgåti - megfordítani

LKZ 80236

Modellname / Model name / Nom du modèle / Modellnamn  
Nome modello / Název modelu / Modelnaam / Ime modela  
Número Modelo / Modell neve / Название модели /  
Názov modelu / Ime modela / Denumire model /  
Наименование на модела / Nazwa modelu

**Synnax**

Modellnummer / Number / Numéro du modèle  
Numero / Номер на модела / modello  
Číslo modelu / Modell száma / Éislo modelu  
Številka modela / Număr model / Broj modela  
Modelnummer / Numer modelu

2134-442-51

Type / Tipo / Tipus / Typ / Тип / Tip

**442**

**D** Unser Direktservice für Beschlagteile  
Sollte Ihnen ein Beschlagteil fehlen, können Sie diese Servicekarte  
direkt an die untenstehende Adresse mailen. Wir können allerdings  
nur Beschlagteile auf diesem Wege verschicken. Sollten Sie eine  
andere Beanstandung an Ihrem Möbelstück haben, so wenden Sie  
sich bitte direkt an Ihr Möbelhaus.

**GB** Our direct order service for fitting  
If a fitting part is missing, you can e-mail this service card directly  
to the address below. However, we can only send fitting parts in  
this way. If you have any other cause for complaint concerning  
your item of furniture, please contact your furniture store directly.

**CZ** Naše přímé služby pro kování  
Chybí-li vám nějaký díl z kování, můžete tuto servisní kartu odeslat  
e-mailem přímo na níže uvedenou adresu. Touto cestou však  
můžeme rozesílat jen díly kování. Pokud byste reklamovali jiný díl  
nábytku, obraťte se přímo na svého prodejce nábytku.

**F** Bien etudier la notice de montage  
S'il vous manque une ferrure, veuillez envoyer directement la présente  
carte service à l'adresse e-mail indiquée ci-dessous. Cependant, ceci  
nous permet uniquement d'envoyer des ferrures. Pour tout autre type  
de réclamation concernant votre meuble, veuillez contacter  
directement votre magasin d'ameublement.

**I** Il nostro servizio diretto per l'ordine della ferramenta  
Qualora Vi dovesse mancare un pezzo di fissaggio, allora Vi  
preghiamo di inviare questa carta di servizio immediatamente  
all'indirizzo sottostante. Possiamo inviare i pezzi di fissaggio  
solamente per mezzo di questo procedimento. Qualora dovesse  
avere qualche altra reclamazione in merito al mobile, allora Vi  
preghiamo di rivolgerVi direttamente al Vostro Negozio di mobili.

**BG** Нашата директна услуга за обкоя  
Ако липсват части от комплекта, попълнете настоящата  
сервисна карта и ни я изпратете на e-mail адреса, посочен  
по-долу. По този начин можем да доставяме само липсващи  
елементи от обкоя. Ако установите други дефекти по  
мебелите, Ви съветваме да се обърнете към мебелната  
къща/магазин, от който сте закупили стоката.

**NL** Onze directservice voor losse onderdelen  
Wanneer er een onderdeel ontbreekt, kunt u deze servicekaart  
direct aan onderstaand e-mailadres sturen. Wij kunnen langs deze  
weg echter alleen beslagdelen versturen. Mocht u een ander  
probleem aan uw meubel hebben, verzoeken wij u contact op te  
nemen met uw meubeldealer.

**PL** Nasz bezpośredni serwis części montażowych  
Jeżeli brakuje części koniecznych do montażu, prosimy o przesłanie  
nam niniejszej karty serwisowej na niżej podany adres e-mailowy.  
W ten sposób możemy przesyłać Państwu tylko brakujące części.  
W przypadku innych reklamacji dotyczących mebla, prosimy zgłosić  
się do salonu meblowego, w którym został dokonany zakup.

**HR** Servis za okove  
U slučaju da nedostaje neki od dijelova molimo vas da na dolje  
navedenu mail adresu pošaljete ovaj servisni obrazac. Na ovaj način  
mogu se dostaviti samo okovi. U slučaju da imate dodatne prigovore  
vezane uz komad namještaja molimo vas da se obratite izravno  
trgovini namještaja gdje je isti kupljen.

**HU** Direktszoigálatunk vasalatok esetén  
Ha hiányzik egy vasalat, ezt a kártyát közvetlenül elküldheti az  
alább található címre. Azonban csakis vasalatok tudunk így  
küldeni. Amennyiben másfajta reklamáció áll fenn bútordarabját  
illetően, forduljon közvetlenül a bútortházhoz.

**SK** Naš priamy servis pre časti kovania  
Ak by Vám chýbala nejaká časť kovania, môžete poslať  
túto servisnú kartu poslať e-mailom na nižšie uvedenú  
adresu. Diely kovania vieme poslať iba týmto spôsobom.  
Ak by ste mali inú reklamáciu ohľadom Vašho nábytku,  
obráťte sa priamo na Vašu predajňu nábytku.

**SLO** Naše direktno uslužne storitve za okovje  
Če vam manjka kakšno okovje, lahko to servisno kartico pošljete  
po e-pošti direktno na spodnji naslov. Po tej poti vam lahko  
pošljemo samo okovje. Če želite reklamirati kakšen drug del  
pohištva, se obrnite neposredno na vašo trgovino pohištva.

**RO** Service-ul nostru direct pentru feronerie  
În cazul în care vă lipsește o piesă de feronerie puteți să trimiteți  
direct acest card de service prin e-mail la adresa de mai jos. Noi  
nu putem expedia piese de feronerie decât pe această cale.  
Dacă aveți o altă reclamație referitoare la piesa de mobilier,  
atunci vă rugăm să vă adresați direct la magazinul dvs. de mobilă.

**RUS** Наш прямой сервис для поставок фурнитуры  
Если окажется, что Вам не хватает того или иного элемента  
фурнитуры, Вы можете отправить сервисную карту по факсу  
непосредственно на нижеприведенный адрес электронной  
почты. Однако, таким образом мы можем пересылать лишь  
фурнитуру. Если же у Вас возникнут иные претензии относительно  
приобретенной мебели, пожалуйста, обращайтесь  
непосредственно в организацию, осуществившую продажу.

**S** Vår direktservice för beslagsdelar  
Om du saknar en beslagsdel kan du skicka detta servicekort direkt  
till e-postadressen som anges nedan. Tänk på att detta är den enda  
möjligheten att skicka beslagsdelar till dig. Om du vill reklamera din  
möbel av en annan anledning måste du kontakta ditt möbelhus direkt.

**ES** Nuestro servicio directo para accesorios  
Si le falta algún accesorio, puede enviar esta tarjeta de servicio directamente  
a la siguiente dirección. No obstante, por este método solo podemos  
enviar accesorios. Si tiene alguna otra objeción sobre su mueble, consulte  
directamente con su mueblería.

**TR** Donatılar için doğrudan servisimiz  
Bir donatınız eksikse bu servis kartını doğrudan aşağıda bulunan adrese  
doğrudan mail yazabilirsiniz. Sadece bu yolla donatılar gönderiliriz.  
Mobilyanızda başka şikayetleriniz varsa lütfen doğrudan mobilya satıcınıza  
danışın.

max

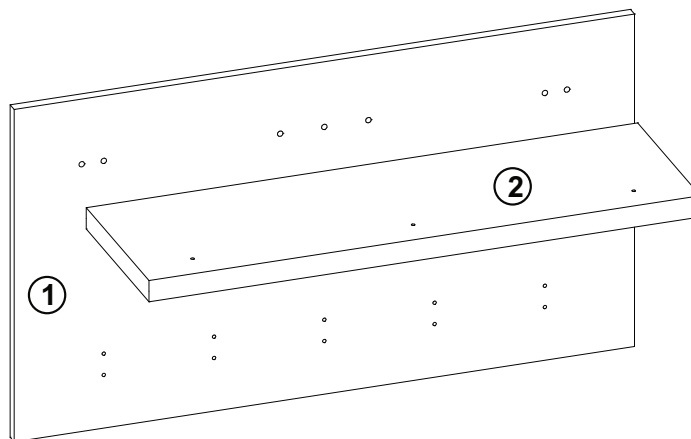

1	900	500	16	x1	1/1
2	800	250	32	x1	1/1

Grund der Beanstandung / Cause for complaint:

Möbelhaus / Furniture store:

Kunde / Customer:

Telefon / Telephone:

PLZ / Postcode:

Ort / City:

Str.+Nr. / Street address

@E-Mail:

LKZ 80236

Modellname / Model name / Nom du modèle / Modelnamn  
 Nome modello / Název modelu / Modelnaam / Ime modela  
 Numéro Modelo / Modell neve / Название модели /  
 Názov modelu / Ime modela / Denumire model /  
 Наименование на модела / Nazwa modelu

**Synnax**





Modellnummer / Number / Numéro du modèle  
 Numero / Номер на модела / modello  
 Číslo modelu / Modell száma / Éislo modelu  
 Številka modela / Număr model / Broj modela  
 Modelnummer / Numer modelu

**2134-442-51**

Type / Tipo / Tipus / Тип / Тип / Tip

**442**

## B1 Colli 1/1

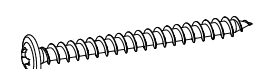
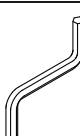
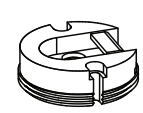
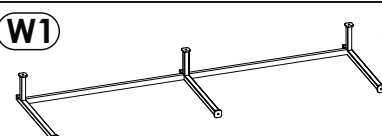
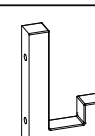
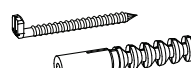
<b>A1</b> 8 x 35 x4 	<b>C2</b> 5x13 x6 	<b>G2</b> 7 x 60 x3 
<b>I10</b> 4 x 24 x10 	<b>I13</b> 4 x 30 x3 	<b>I16</b> 4 x 45 x3 
<b>M</b>  x1	<b>P1</b>  x3	<b>W1</b>  x1
<b>W2</b>  x5	<b>Y2</b>  x3 Ø10	

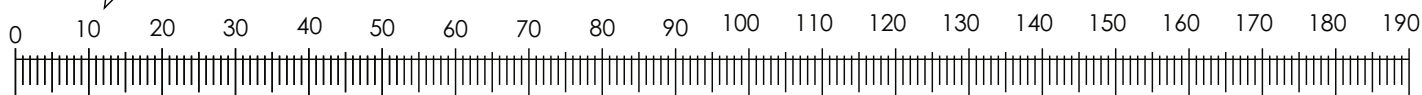
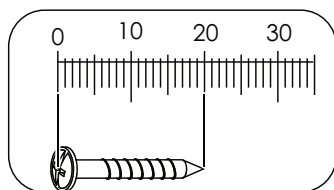

MM

1

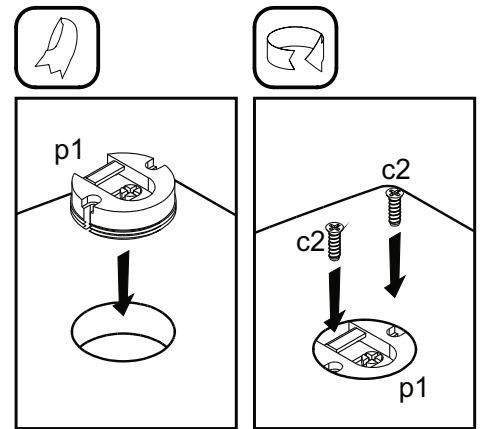
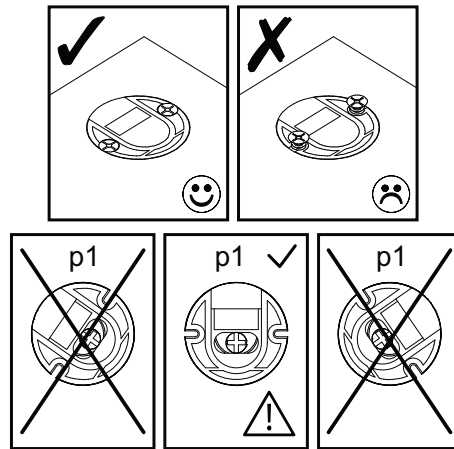
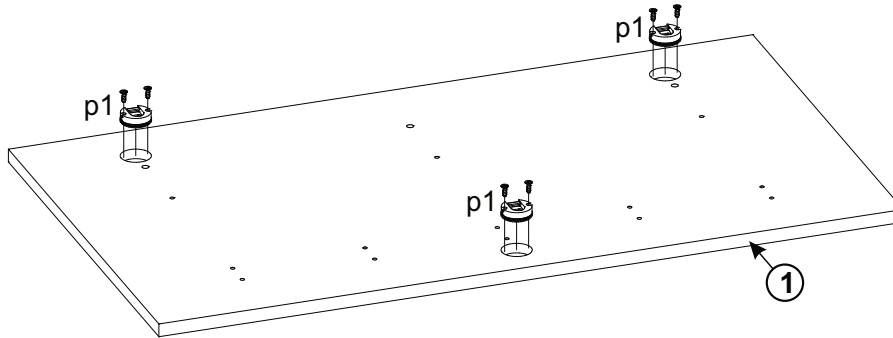
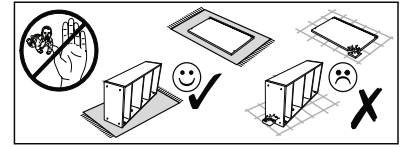
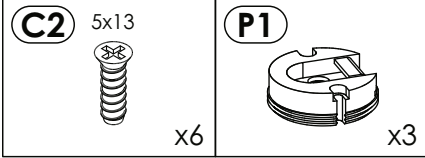

2

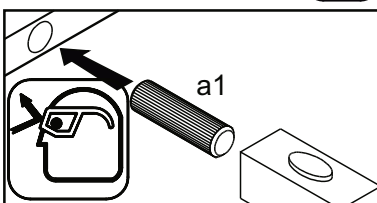
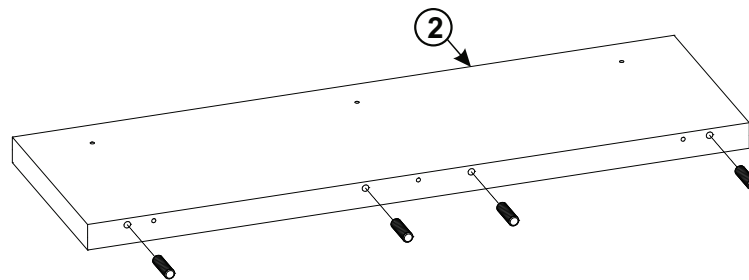
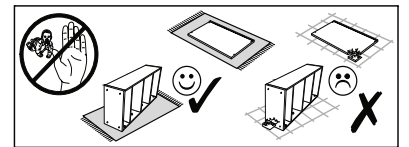
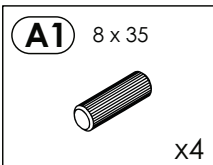

3

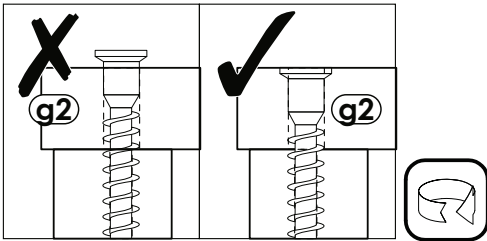
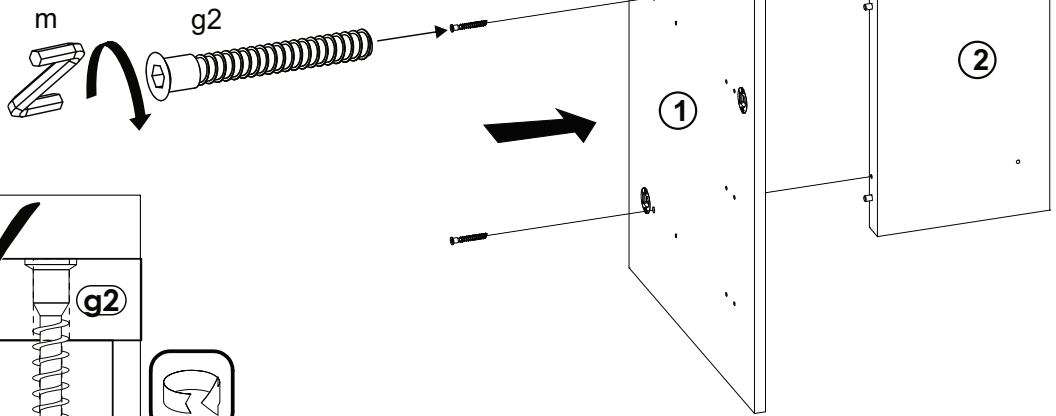
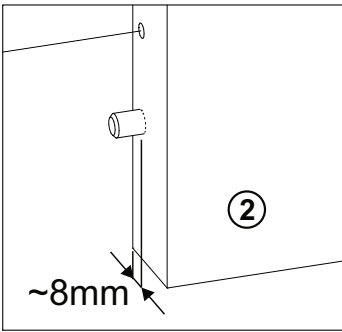
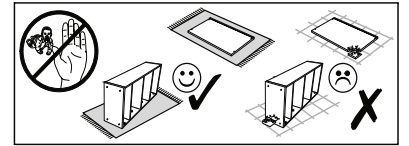
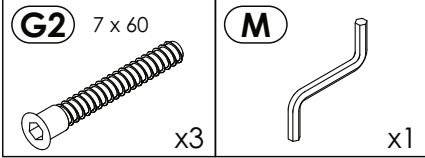

4

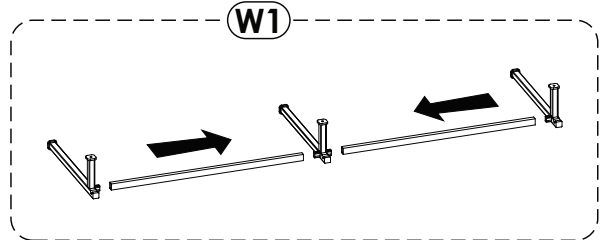
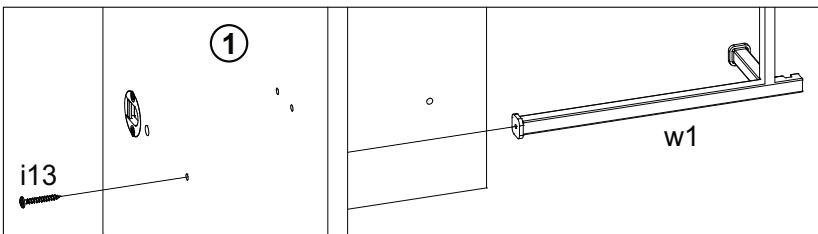
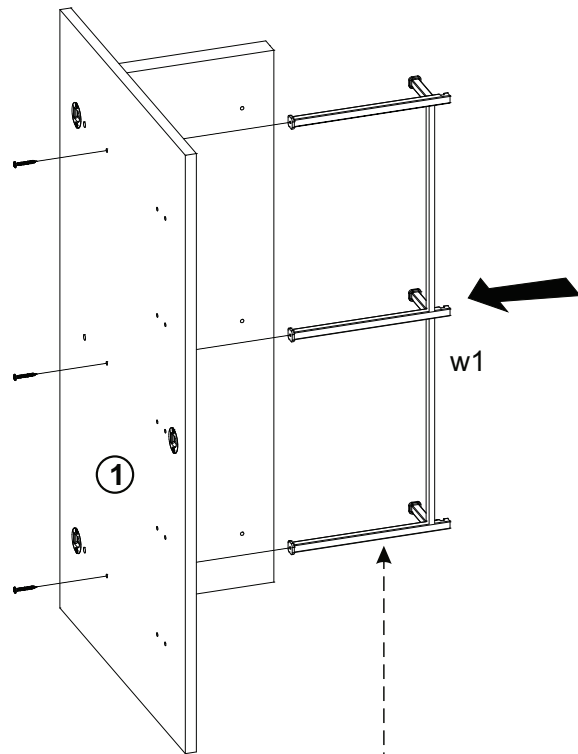
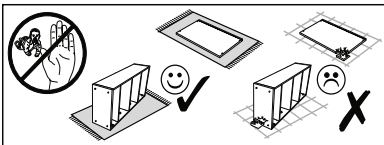
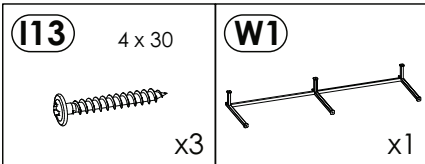

5

**i16**

4 x 45



x3

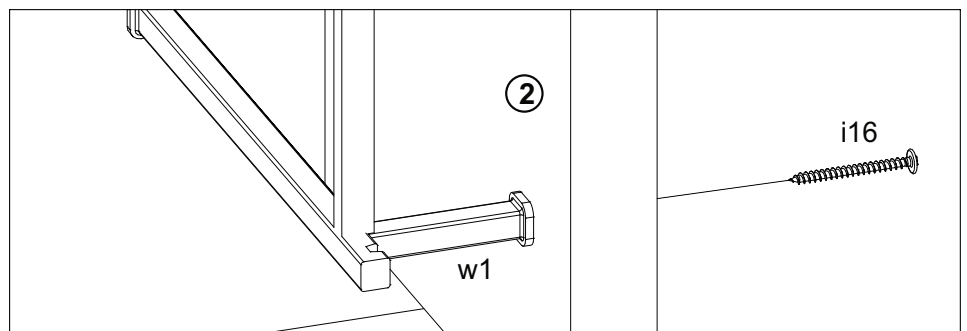
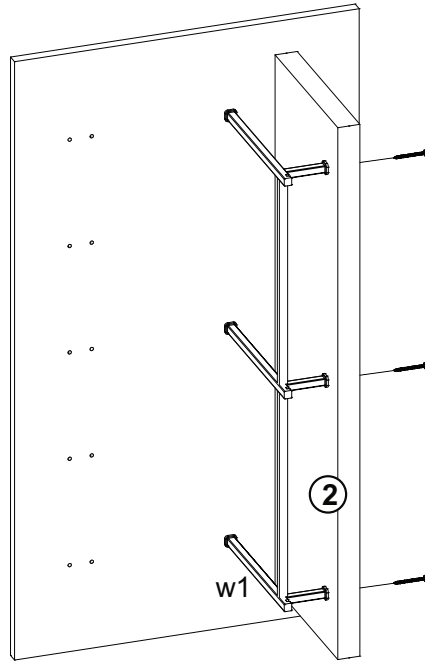
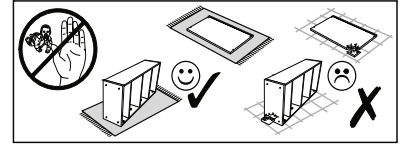

6

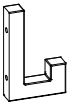
<b>I10</b> 4 x 24  x10	<b>W2</b>  x5
------------------------------------------------------------------------------------------------------------------	------------------------------------------------------------------------------------------------------

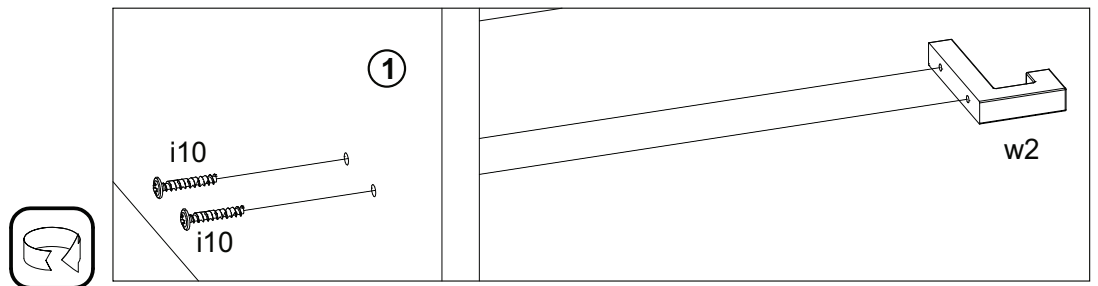
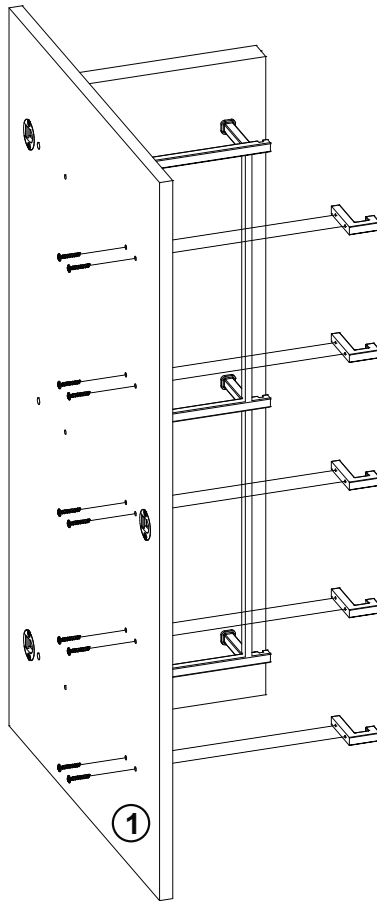
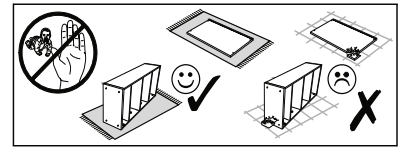

7

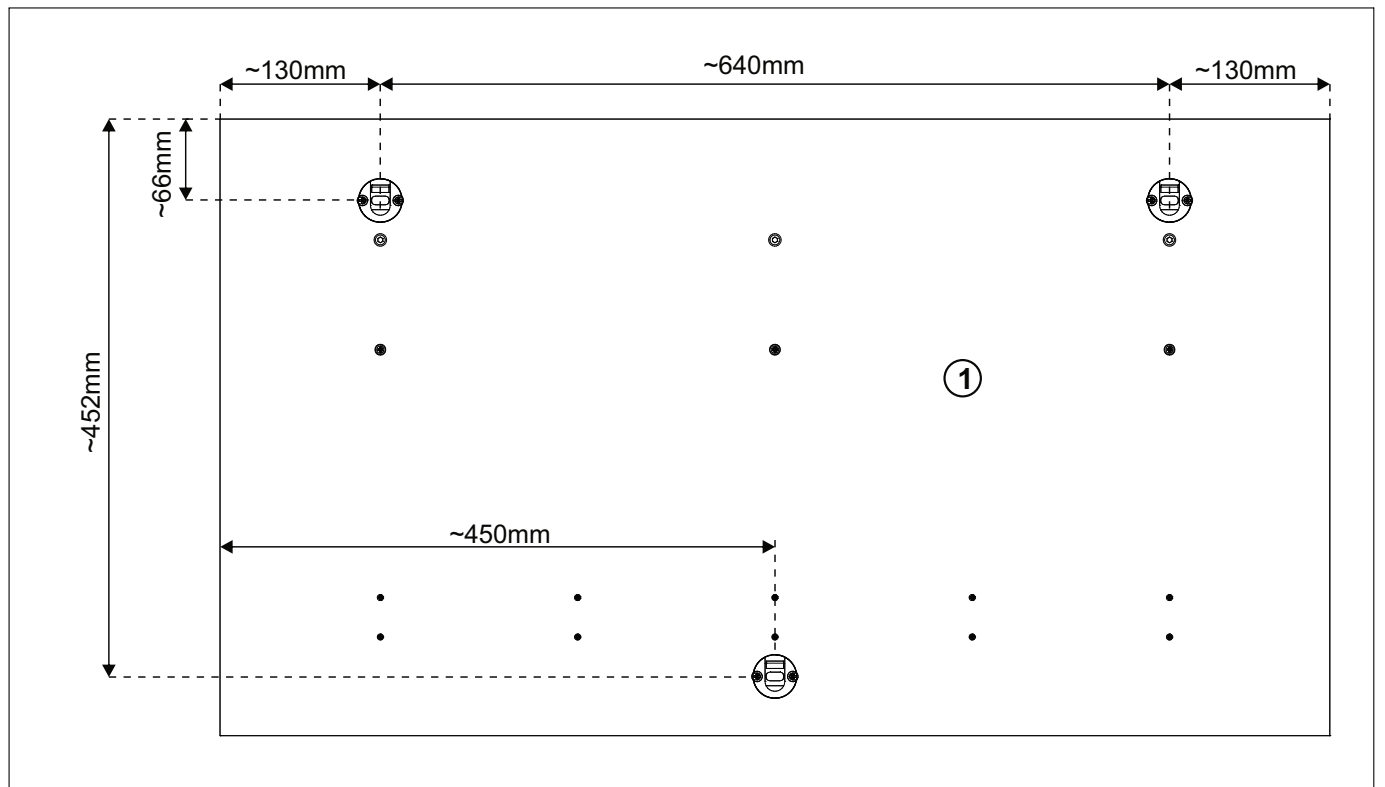
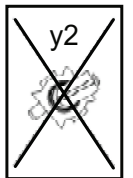
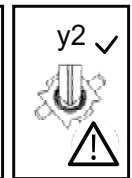
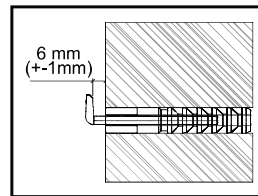
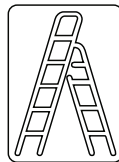
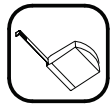
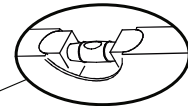
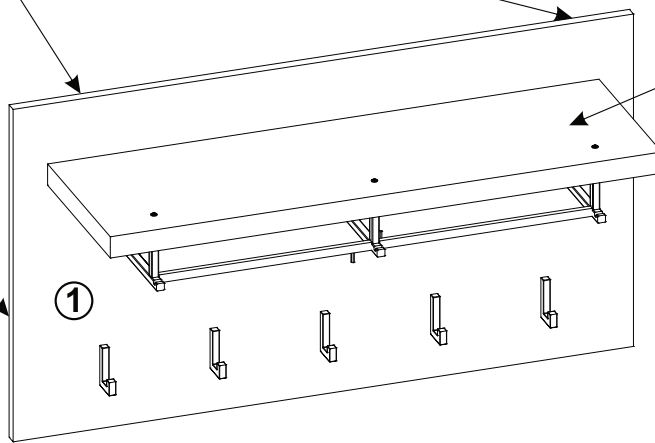
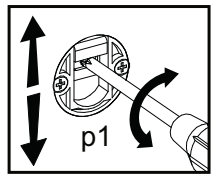
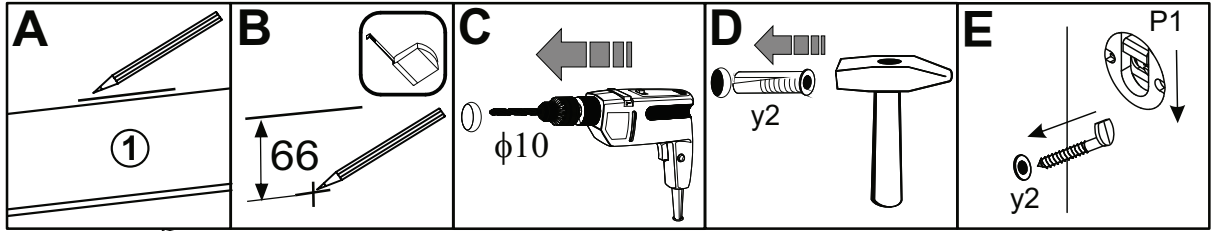
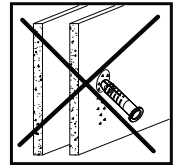
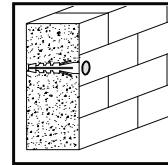
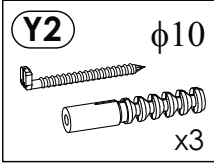



LKZ 80236

Modellname / Model name / Nom du modèle / Modellnamn / Nome modello / Název modelu / Modelnaam / Ime modela / Numéro Modelo / Modell neve / Название модели / Názov modelu / Ime modela / Denumire model / Наименование на модела / Nazwa modelu

**Synnax**

Modellnummer / Number / Numéro du modèle / Numero / Номер на модела / modello / Číslo modelu / Modell száma / Éislo modelu / Številka modela / Număr model / Broj modela / Modelnummer / Numer modelu

**2134-452-51**

Type / Tipo / Tipus / Тип / Тип / Tip

**452**

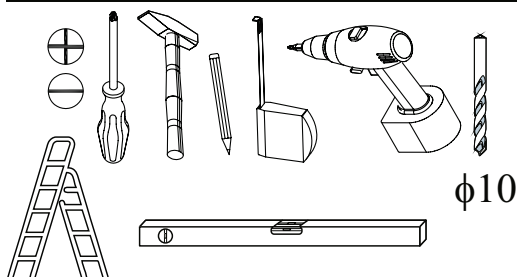
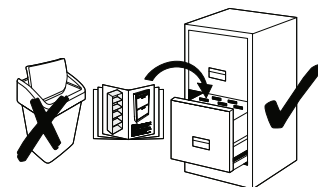
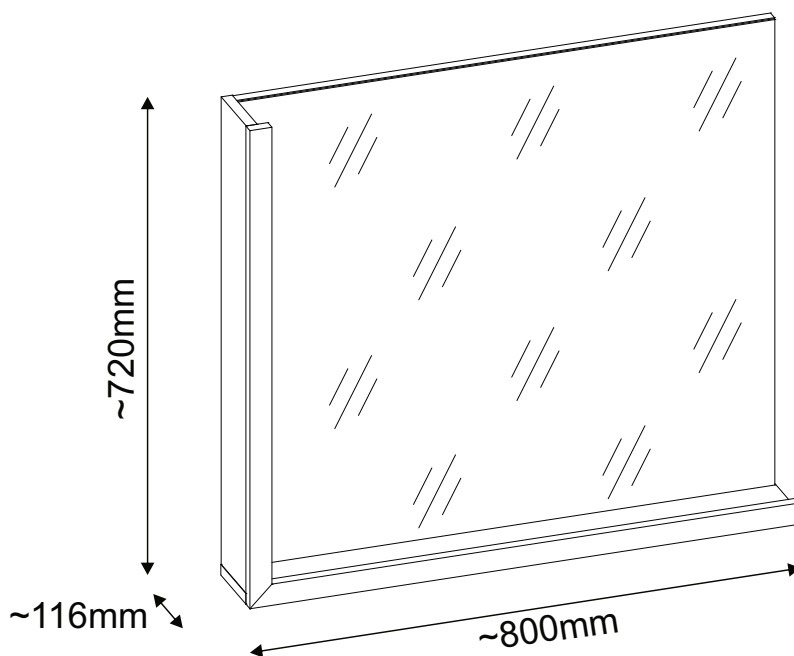
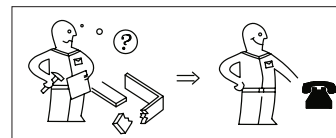
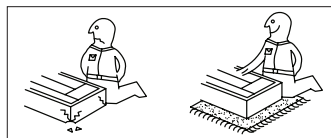
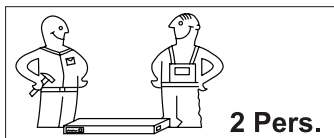

festziehen / tighten / Затягнэне / serrer / stringere / utåhnout / vasttrekken / zategnuti / strångere / zwiázac / zacisnaç / szorosan meghúzni / pevne dotiahnut / trdno pritegniti / затянуть / dra át



eindrücken / press in / enfoncer / wcisnaç / ribattere / zatlačit / Вкарайте / indrukken / benyomni / stlačit / vtisniti / tryck in / introducere prin apă sare / вдавить



ausmessen / measure / mesurer / misurare / opmeten / izmeriti / miara / kimérni / izmeriti / măsurare / измерить / změřit / Измерете / mät upp / zmierzyc



drücken / press / presser / stisknout / Натиснэне / vtisniti / nasinac / drukken / pritisnuti / nacinac / pritisniti / нажать / (meg)nyomni / apă sare / tryck fast / nacinac



einschlagen / hammer in / beverni / sla in / frapper au marteau / infossare / Zabit / zarazit / Набийте / zabiti / wbić / introducere prin bătaie / забить / zatlout



Drehen - wenden / przekrećić - odwrócić / Keren - omdraaien / Girare - Ruotare / Okrenuti - ubnuti / Retourner - renverser / Turn over - turn around / Otočte - obratite / Завъртете - обърнэне / Obrnite list / întoarceți - rotiți / Vrid runt - vänd / прокрутить - повернуть / otočit - obrátit / elforgatni - megfordítani

Modellname / Model name / Nom du modèle / Modelnamn  
Nome modello / Název modelu / Modelnaam / Ime modela  
Número Modelo / Modell neve / Название модели /  
Názov modelu / Ime modela / Denumire model /  
Наименование на модела / Nazwa modelu

**Synnax**

Modellnummer / Number / Numéro du modèle  
Numero / Номер на модела / modello  
Číslo modelu / Modell száma / Éislo modelu  
Številka modela / Număr model / Broj modela  
Modelnummer / Numer modelu

2134-452-51

Type / Tipo / Tipus / Тип / Тип / Tip

**452**

LKZ 80236

**D** Unser Direktservice für Beschlagteile  
Sollte Ihnen ein Beschlagteil fehlen, können Sie diese Servicekarte  
direkt an die untenstehende Adresse mailen. Wir können allerdings  
nur Beschlagteile auf diesem Wege verschicken. Sollten Sie eine  
andere Beanstandung an Ihrem Möbelstück haben, so wenden Sie  
sich bitte direkt an Ihr Möbelhaus.

**GB** Our direct order service for fitting  
If a fitting part is missing, you can e-mail this service card directly  
to the address below. However, we can only send fitting parts in  
this way. If you have any other cause for complaint concerning  
your item of furniture, please contact your furniture store directly.

**CZ** Naše přímé služby pro kování  
Chybí-li vám nějaký díl z kování, můžete tuto servisní kartu odeslat  
e-mailem přímo na níže uvedenou adresu. Touto cestou však  
můžeme rozesílat jen díly kování. Pokud byste reklamovali jiný díl  
nábytku, obraťte se přímo na svého prodejce nábytku.

**F** Bien etudier la notice de montage  
S'il vous manque une ferrure, veuillez envoyer directement la présente  
carte service à l'adresse e-mail indiquée ci-dessous. Cependant, ceci  
nous permet uniquement d'envoyer des ferrures. Pour tout autre type  
de réclamation concernant votre meuble, veuillez contacter  
directement votre magasin d'ameublement.

**I** Il nostro servizio diretto per l'ordine della ferramenta  
Qualora Vi dovesse mancare un pezzo di fissaggio, allora Vi  
preghiamo di inviare questa carta di servizio immediatamente  
all'indirizzo sottostante. Possiamo inviare i pezzi di fissaggio  
solamente per mezzo di questo procedimento. Qualora dovesse  
avere qualche altra reclamazione in merito al mobile, allora Vi  
preghiamo di rivolgerVi direttamente al Vostro Negozio di mobili.

**BG** Нашата директна услуга за обкоя  
Ако липсват части от комплекта, попълнете настоящата  
сервисна карта и ни я изпратете на e-mail адреса, посочен  
по-долу. По този начин можем да доставяме само липсващи  
елементи от обкоя. Ако установите други дефекти по  
мебелите, Ви съветваме да се обърнете към мебелната  
къща/магазин, от който сте закупили стоката.

**NL** Onze directservice voor losse onderdelen  
Wanneer er een onderdeel ontbreekt, kunt u deze servicekaart  
direct aan onderstaand e-mailadres sturen. Wij kunnen langs deze  
weg echter alleen beslagdelen versturen. Mocht u een ander  
probleem aan uw meubel hebben, verzoeken wij u contact op te  
nemen met uw meubeldealer.

**PL** Nasz bezpośredni serwis części montażowych  
Jeżeli brakuje części koniecznych do montażu, prosimy o przesłanie  
nam niniejszej karty serwisowej na niżej podany adres e-mailowy.  
W ten sposób możemy przesyłać Państwu tylko brakujące części.  
W przypadku innych reklamacji dotyczących mebla, prosimy zgłosić  
się do salonu meblowego, w którym został dokonany zakup.

**HR** Servis za okove  
U slučaju da nedostaje neki od dijelova molimo vas da na dolje  
navedenu mail adresu pošaljete ovaj servisni obrazac. Na ovaj način  
mogu se dostaviti samo okovi. U slučaju da imate dodatne prigovore  
vezane uz komad namještaja molimo vas da se obratite izravno  
trgovini namještaja gdje je isti kupljen.

**HU** Direktszoigálatunk vasalatok esetén  
Ha hiányzik egy vasalat, ezt a kártyát közvetlenül elküldheti az  
alább található címre. Azonban csak vasalatok tudunk így  
küldeni. Amennyiben másfajta reklamáció áll fenn bútordarabját  
illetően, forduljon közvetlenül a bútortházhoz.

**SK** Náš priamy servis pre časti kovania  
Ak by Vám chýbala nejaká časť kovania, môžete poslať  
túto servisnú kartu poslať e-mailom na nižšie uvedenú  
adresu. Diely kovania vieme poslať iba týmto spôsobom.  
Ak by ste mali inú reklamáciu oľhľadom Vašho nábytku,  
obráťte sa priamo na Vašu predajňu nábytku.

**SLO** Naše direktno uslužne storitve za okovje  
Če vam manjka kakšno okovje, lahko to servisno kartico pošljete  
po e-pošti direktno na spodnji naslov. Po tej poti vam lahko  
pošljemo samo okovje. Če želite reklamirati kakšen drug del  
pohištva, se obrnite neposredno na vašo trgovino pohištva.

**RO** Service-ul nostru direct pentru feronerie  
În cazul în care vă lipsește o piesă de feronerie puteți să trimiteți  
direct acest card de service prin e-mail la adresa de mai jos. Noi  
nu putem expedia piese de feronerie decât pe această cale.  
Dacă aveți o altă reclamație referitoare la piesa de mobilier,  
atunci vă rugăm să vă adresați direct la magazinul dvs. de mobilă.

**RUS** Наш прямой сервис для поставок фурнитуры  
Если окажется, что Вам не хватает того или иного элемента  
фурнитуры, Вы можете отправить сервисную карту по факсу  
непосредственно на нижеприведенный адрес электронной  
почты. Однако, таким образом мы можем пересылать лишь  
фурнитуру. Если же у Вас возникнут иные претензии относительно  
приобретенной мебели, пожалуйста, обращайтесь  
непосредственно в организацию, осуществившую продажу.

**S** Vår direktservice för beslagsdelar  
Om du saknar en beslagsdel kan du skicka detta servicekort direkt  
till e-postadressen som anges nedan. Tänk på att detta är den enda  
möjligheten att skicka beslagsdelar till dig. Om du vill reklamera din  
möbel av en annan anledning måste du kontakta ditt möbelhus direkt.

**ES** Nuestro servicio directo para accesorios  
Si le falta algún accesorio, puede enviar esta tarjeta de servicio directamente  
a la siguiente dirección. No obstante, por este método solo podemos  
enviar accesorios. Si tiene alguna otra objeción sobre su mueble, consulte  
directamente con su mueblería.

**TR** Donatılar için doğrudan servisimiz  
Bir donatınız eksikse bu servis kartını doğrudan aşağıda bulunan adrese  
doğrudan mail yazabilirsiniz. Sadece bu yolla donatılar gönderiliriz.  
Mobilyanızda başka şikayetleriniz varsa lütfen doğrudan mobilya satıcınıza  
danışın.

max

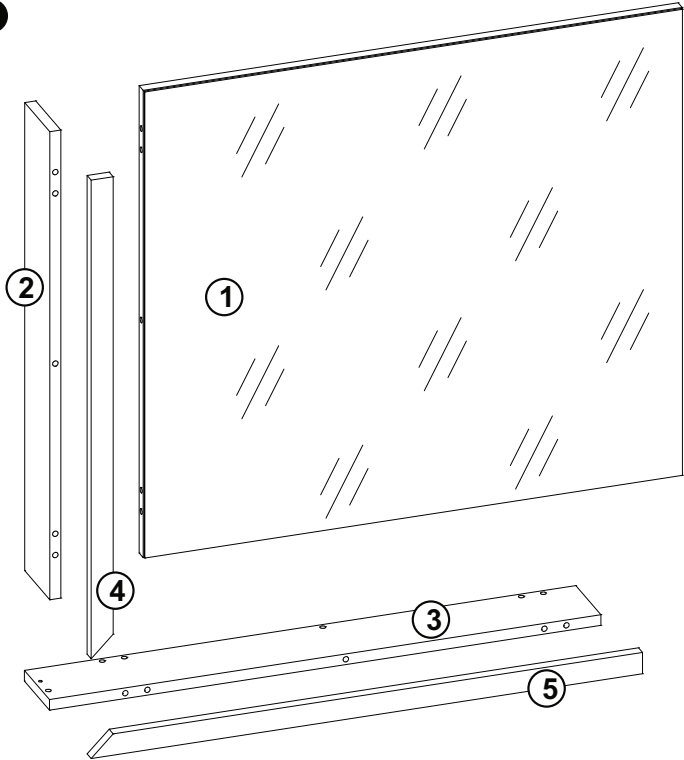

1	782	703	20	x1	1/1
2	704	100	16	x1	1/1
3	800	100	16	x1	1/1
4	720	32	16	x1	1/1
5	800	32	16	x1	1/1

Grund der Beanstandung / Cause for complaint:

Möbelhaus / Furniture store:

Kunde / Customer:

Telefon / Telephone:

PLZ / Postcode:

Ort / City:

Str.+Nr. / Street address

@E-Mail:

Modellname / Model name / Nom du modèle / Modelnamn  
 Nome modello / Název modelu / Modelnaam / Ime modela  
 Numéro Modelo / Modell neve / Название модели /  
 Názov modelu / Ime modela / Denumire model /  
 Наименование на модела / Nazwa modelu

**Synnax**

LKZ 80236











Modellnummer / Number / Numéro du modèle  
 Numero / Номер на модела / modello  
 Číslo modelu / Modell száma / Éislo modelu  
 Številka modela / Număr model / Broj modela  
 Modelnummer / Numer modelu

**2134-452-51**

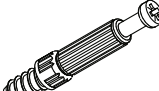
Type / Tipo / Tipus / Тип / Тип / Tip

**452**

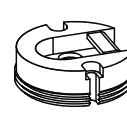
## B1 Colli 1/1

<b>A1</b> 8 x 35 x9 	<b>C2</b> 5x13 x6 	<b>E0</b> x7 
<b>E1</b> 15 x 12,5 x10 	<b>F1</b> x10 	<b>G0</b> x3 
<b>G2</b> 7 x 60 x3 	<b>M</b> x1 	<b>P1</b> x3 
<b>Y2</b> x3  Ø10		

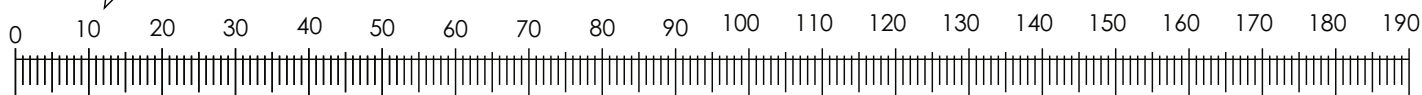
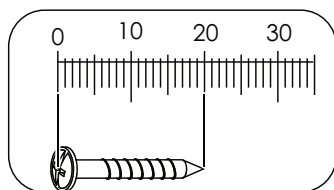

MM

1

A1 8 x 35



x3

E1 15 x 12,5

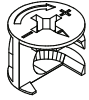

x4

F1

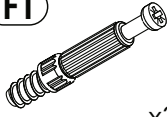

x3

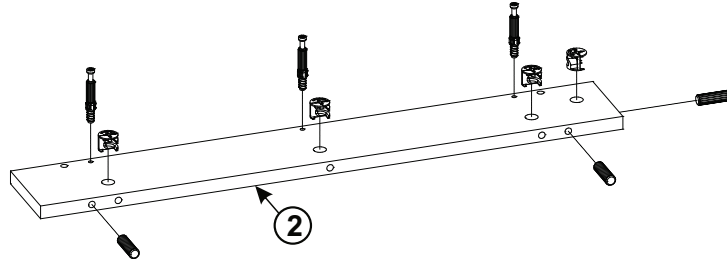
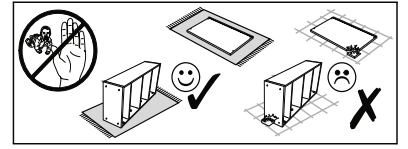

2

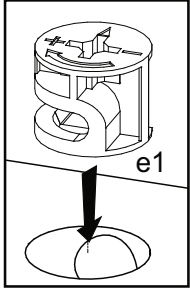

e1

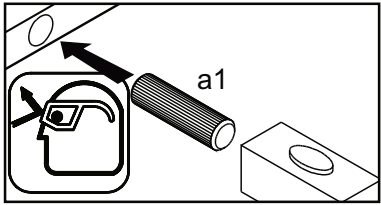

a1

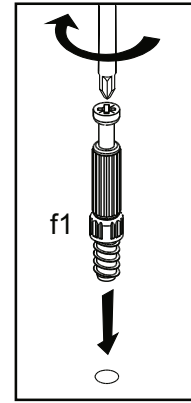
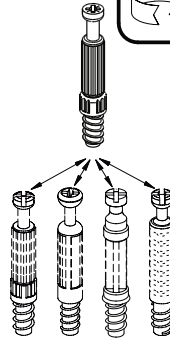

f1

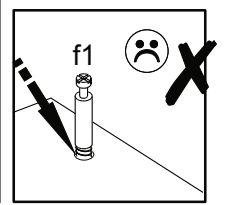
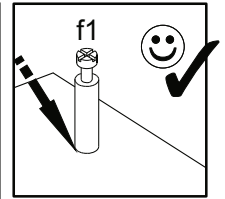

2

A1 8 x 35



x4

C2 5x13



x6

E1 15 x 12,5



x3

P1



x3

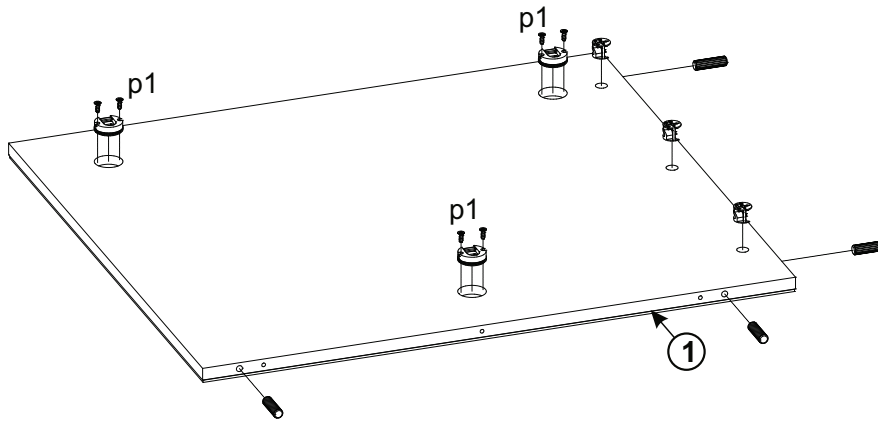
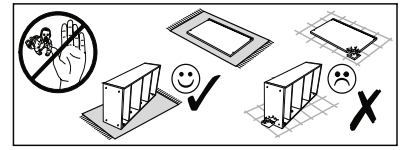

1

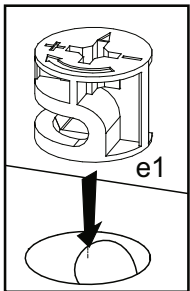
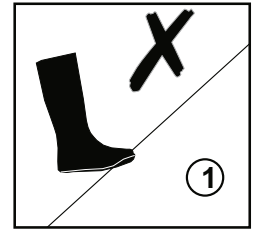

e1

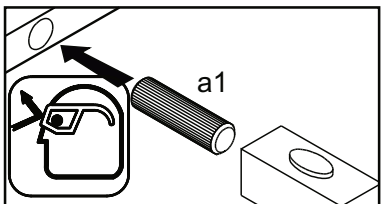

a1

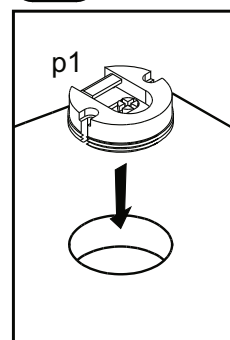
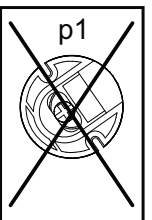
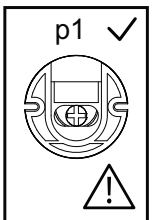
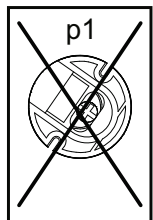
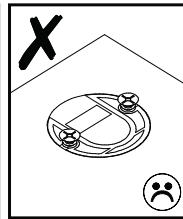
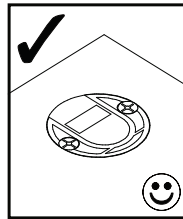

p1

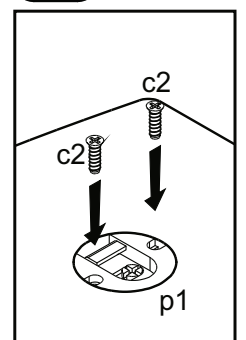

c2

p1

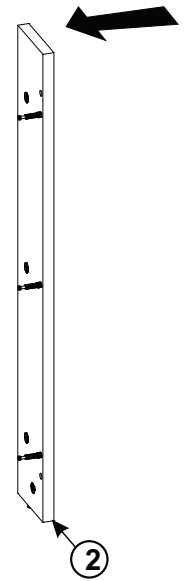
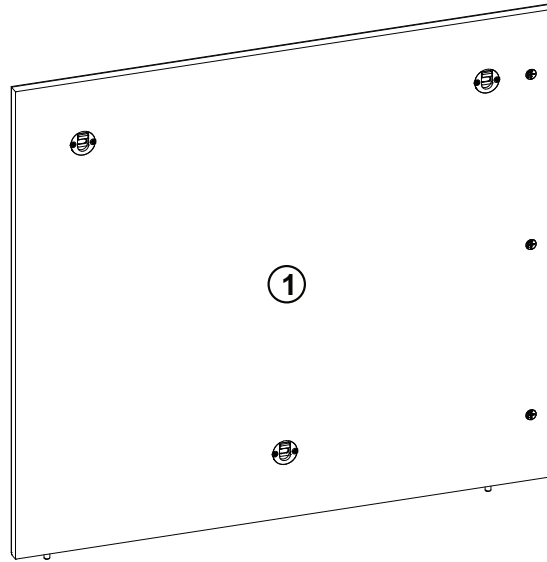
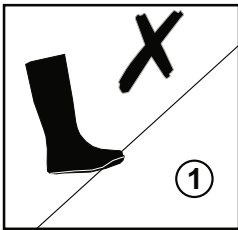
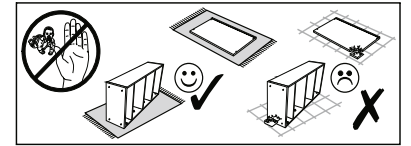
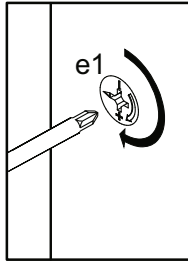
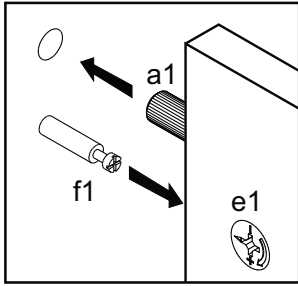

3

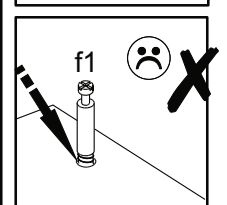
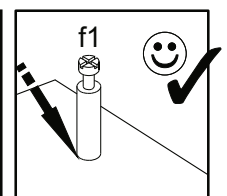
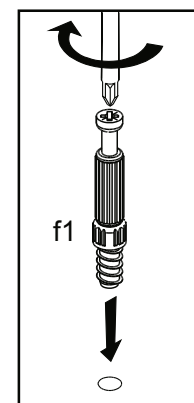
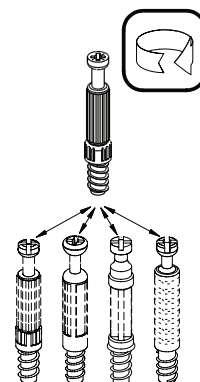
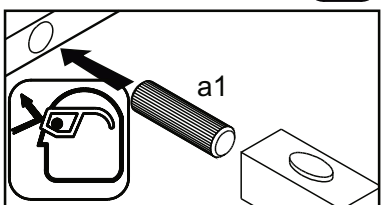
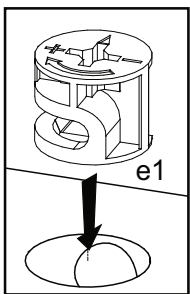
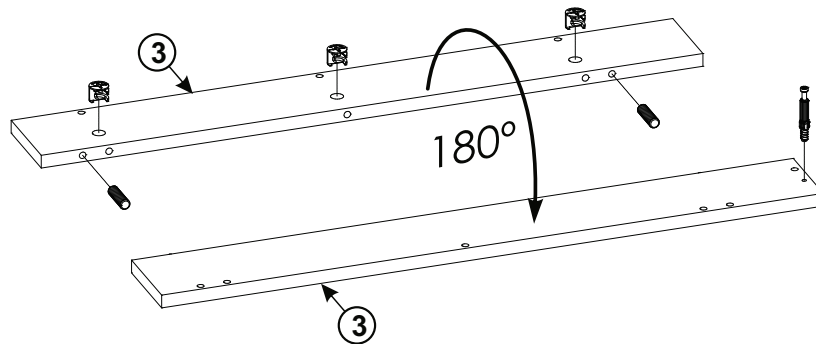
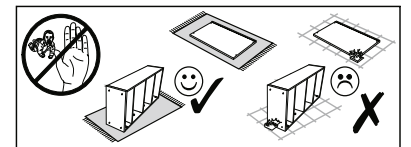
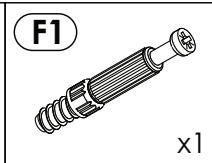
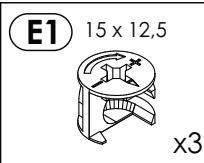
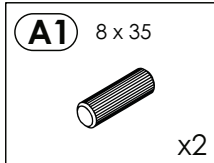

4

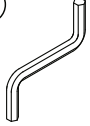

5

<p><b>E0</b></p>  <p>x1</p>	<p><b>G0</b></p>  <p>x3</p>	<p><b>G2</b> 7 x 60</p>  <p>x3</p>	<p><b>M</b></p>  <p>x1</p>
--------------------------------------------------------------------------------------------------------------	--------------------------------------------------------------------------------------------------------------	---------------------------------------------------------------------------------------------------------------------	-------------------------------------------------------------------------------------------------------------

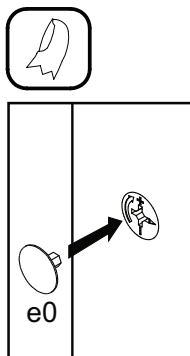
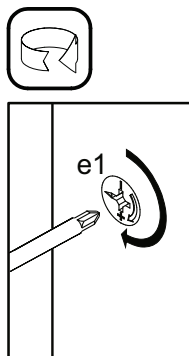
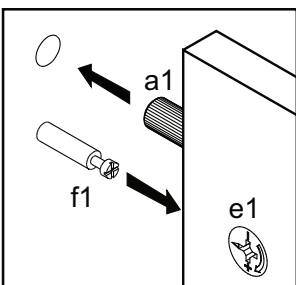
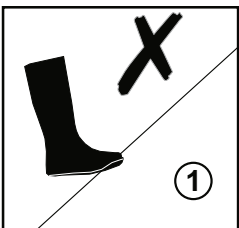
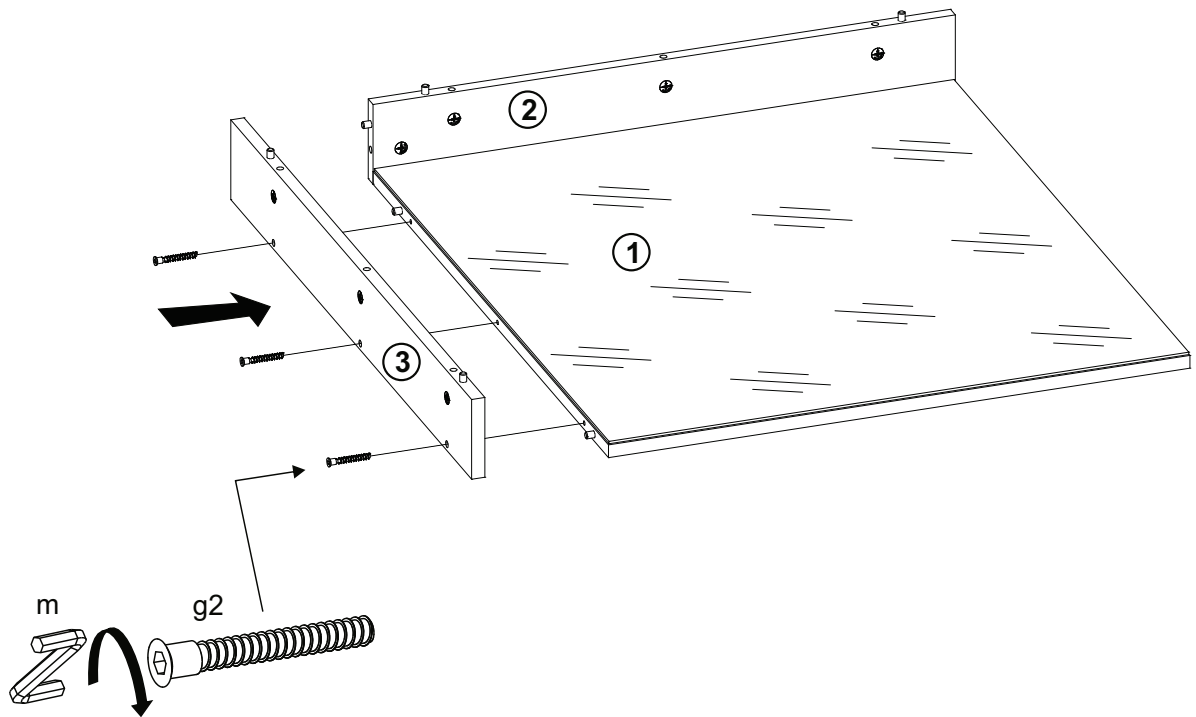
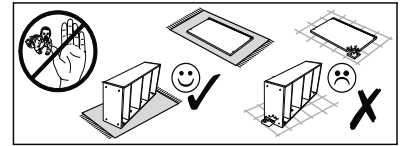

<p><b>X</b></p>	<p><b>✓</b></p>
-----------------	-----------------

6

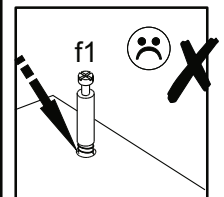
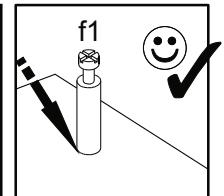
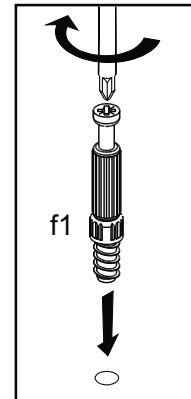
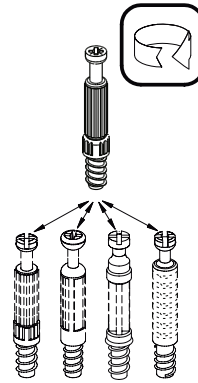
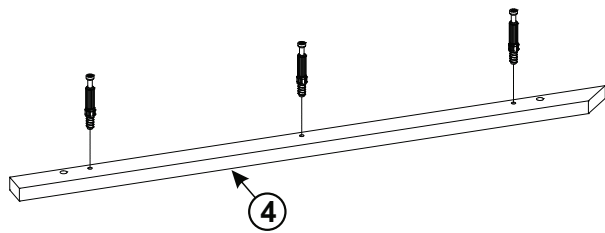
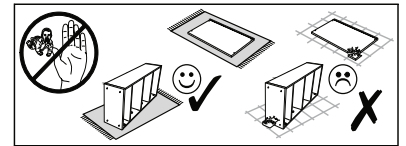
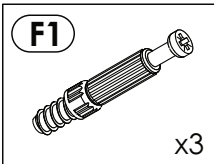

7

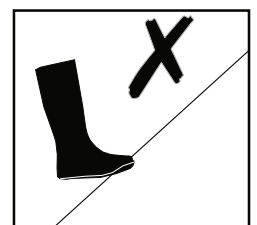
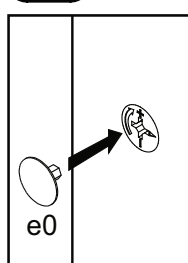
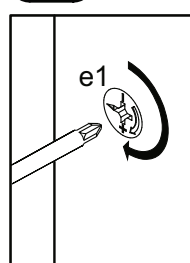
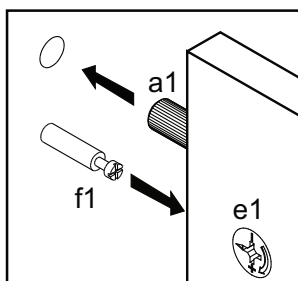
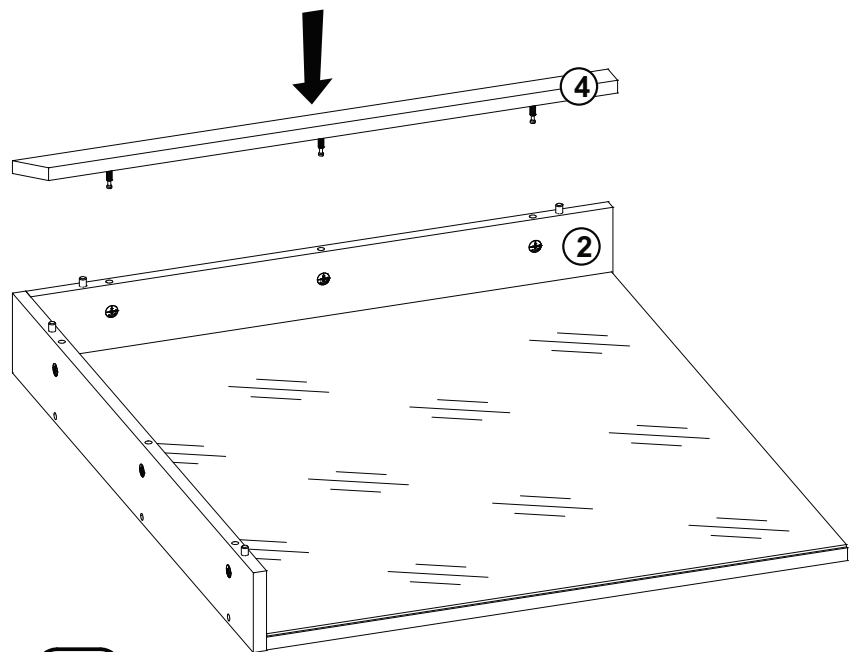
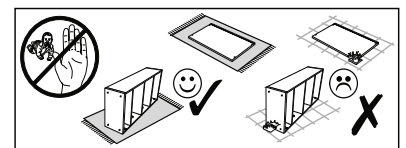
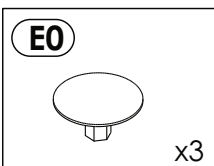

8

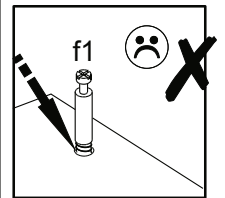
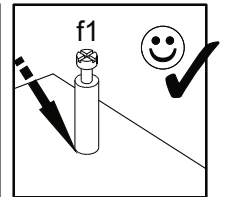
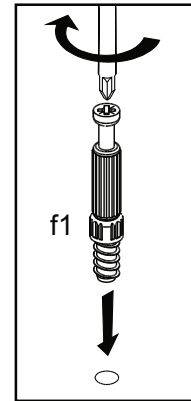
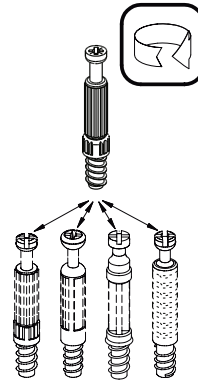
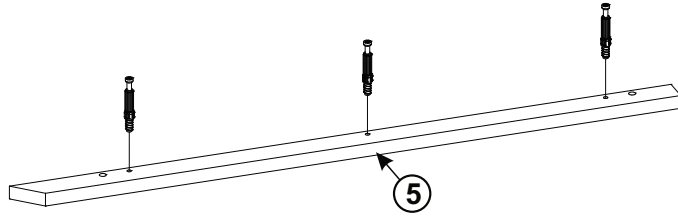
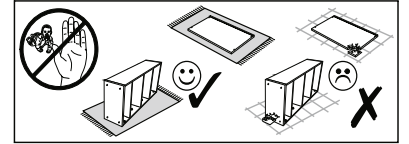
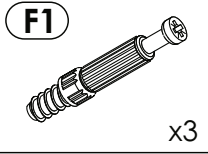

9

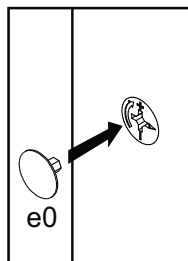
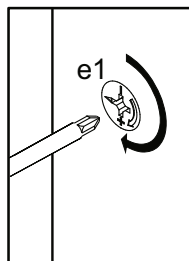
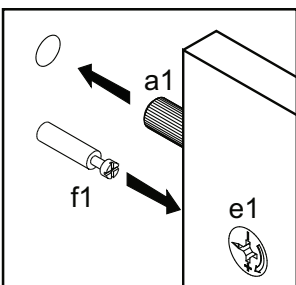
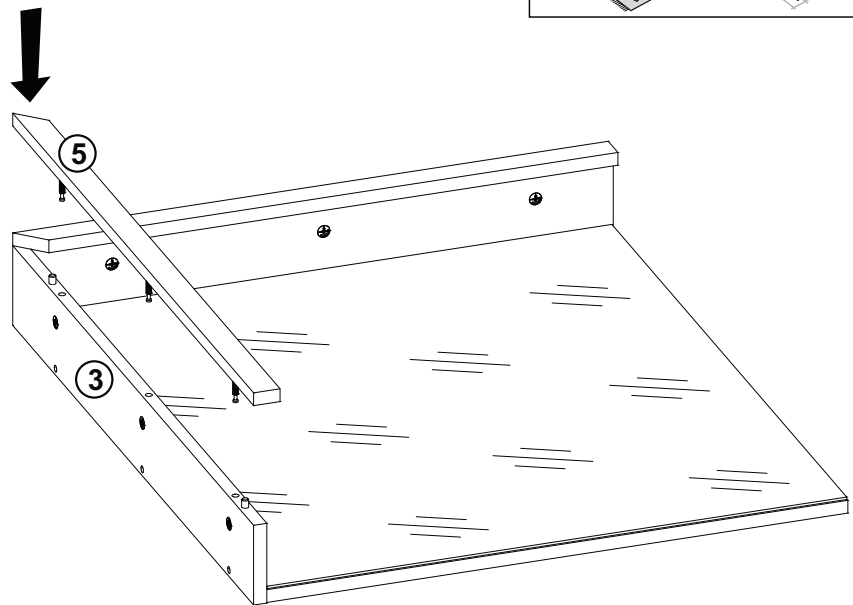
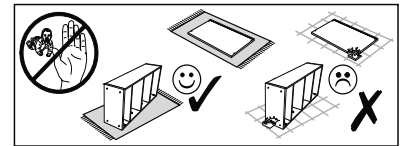
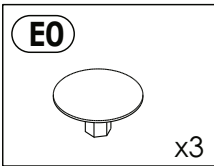



10

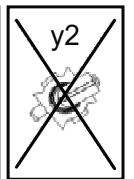
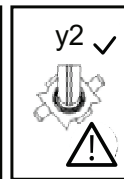
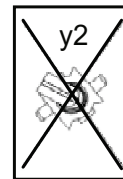
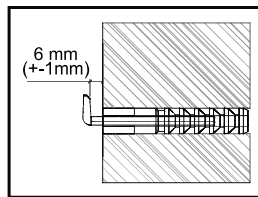
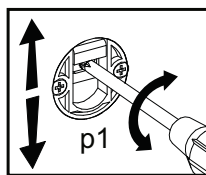
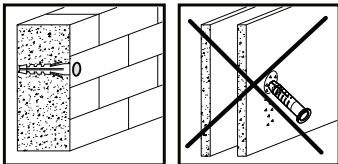
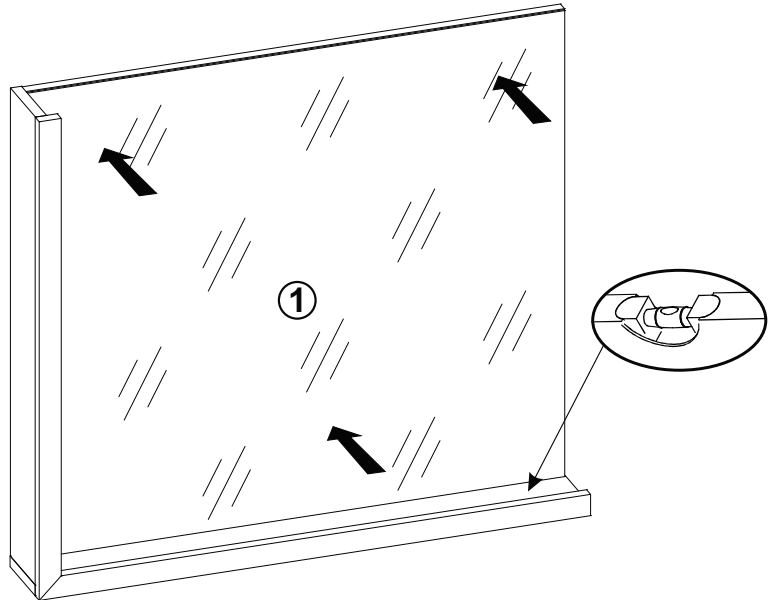
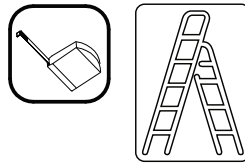
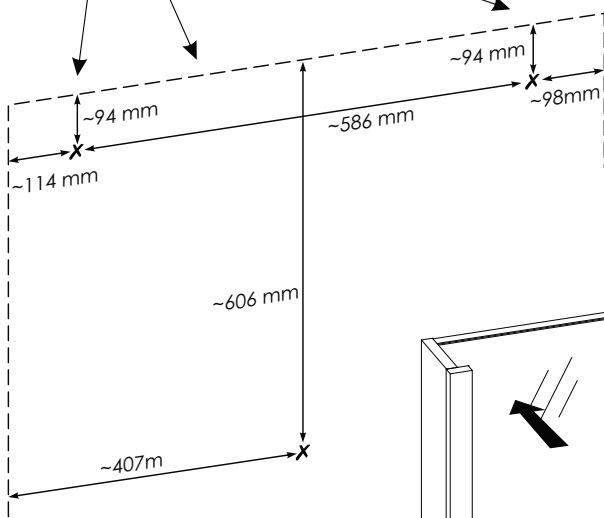
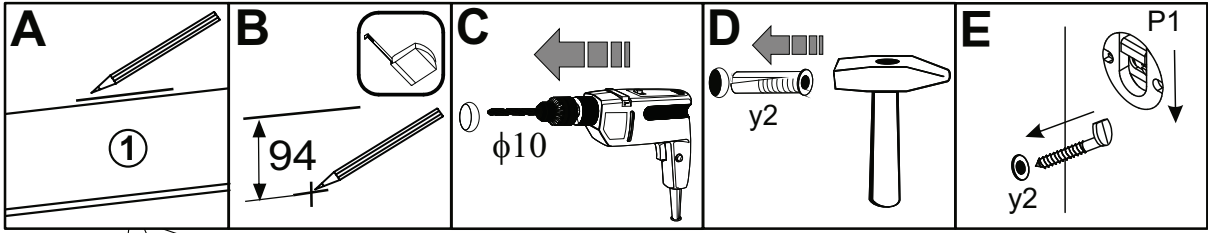
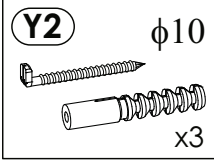

LKZ 80236

Modellname / Model name / Nom du modèle / Modellnamn / Nome modello / Název modelu / Modelnaam / Ime modela / Numéro Modelo / Modell neve / Название модели / Názov modelu / Ime modela / Denumire model / Наименование на модела / Nazwa modelu

**SynnaX**

Modellnummer / Number / Numéro du modèle / Numero / Номер на модела / modello / Číslo modelu / Modell száma / Ěíslo modelu / Številka modela / Număr model / Broj modela / Modelnummer / Numer modelu

**2134-866-84**

Type / Tipo / Tipus / Typ / Тип / Tip

**866**

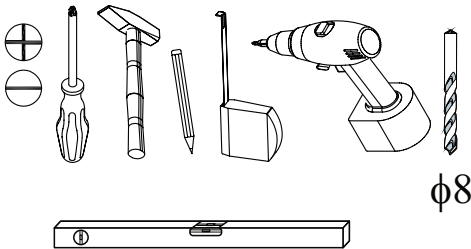
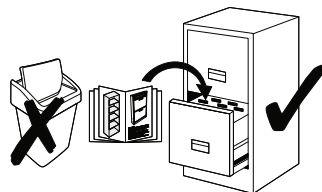
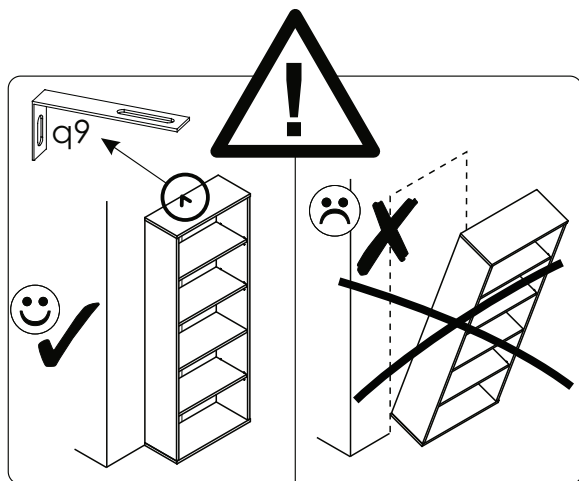
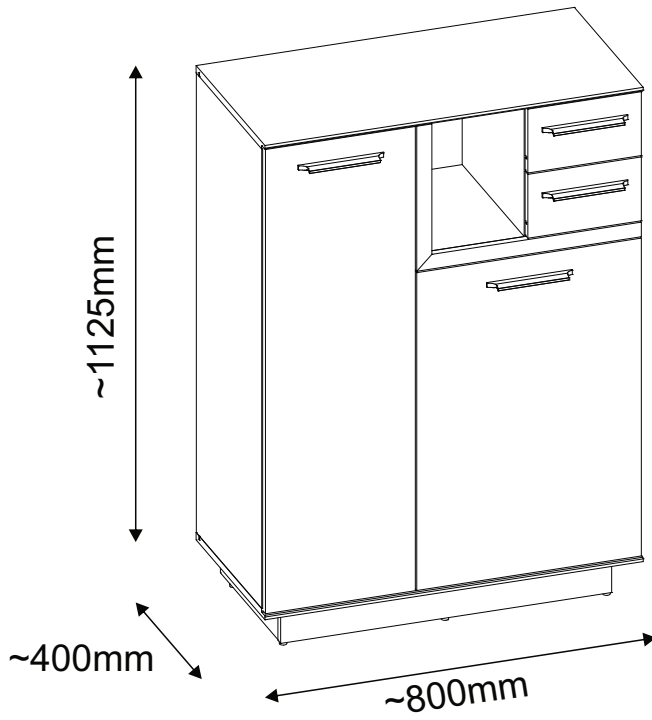
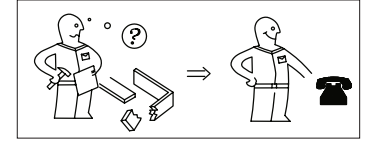
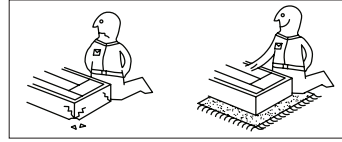
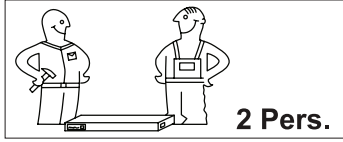

festziehen / tighten / Затягнете / serrer / stringere / utåhncout / vasttrekken / zategnuti / strångere / zwiázac / zacisnac / szorosan meghúzni / pevne dotiahnut' / trdno pritegniti / затянуть / dra át



eindrücken / press in / enfonceur / wcisnac / ribattere / zatlačit / Вкарайте / indrukken / benyomni / stlačit' / vtisniti / tryck in / introducere prin apăsare / вдвигать



ausmessen / measure / mesurer / misurare / opmeten / izmeriti / miara / kimérni / izmeriti / măsurare / измерить / změřit / Измерете / mät upp / zmierzyc



drücken / press / presser / stisknout / Keren - omdraaien / Girare - Ruotare / pritisnuti / nacisnac / pritisniti / нажать / (meg)nyomni / apăsare / tryck fast / nacisnac



einschlagen / hammer in / beverni / sla in / frapper au marteau / infossare / Zabit' / zarazit / Набийте / zabiti / wbić / introducere prin bătaie / забить / zatloout



Drehen - wenden / przekrećić - odwrócić / Okrenuti - ubrnuti / Retourner - renverser / Turn over - turn around / Otočte - obratite / Zавъртете - обърнете / Obrnite list / Întoarceți - rotiți / Vrid runt - vänd / прокрутить - повернуть / otočit - obrátit / elforgatni - megfordítani

LKZ 80236

Modellname / Model name / Nom du modèle / Modellnamn  
Nome modello / Název modelu / Modelnaam / Ime modela  
Número Modelo / Modell neve / Название модели /  
Názov modelu / Ime modela / Denumire model /  
Наименование на модела / Nazwa modelu

**Synnax**

Modellnummer / Number / Numéro du modèle  
Numero / Номер на модела / modello  
Číslo modelu / Modell száma / Éíslo modelu  
Številka modela / Număr model / Broj modela  
Modelnummer / Numer modelu

2134-866-84

Type / Tipo / Tipus / Typ / Тип / Tip

**866**

**D** Unser Direktservice für Beschlagteile  
Sollte Ihnen ein Beschlagteil fehlen, können Sie diese Servicekarte  
direkt an die untenstehende Adresse mailen. Wir können allerdings  
nur Beschlagteile auf diesem Wege verschicken. Sollten Sie eine  
andere Beanstandung an Ihrem Möbelstück haben, so wenden Sie  
sich bitte direkt an Ihr Möbelhaus.

**GB** Our direct order service for fitting  
If a fitting part is missing, you can e-mail this service card directly  
to the address below. However, we can only send fitting parts in  
this way. If you have any other cause for complaint concerning  
your item of furniture, please contact your furniture store directly.

**CZ** Náša príjemná služba pro kování  
Chybí-li vám nějaký díl z kování, můžete tuto servisní kartu odeslat  
e-mailem přímo na níže uvedenou adresu. Touto cestou však  
můžeme rozslat jen díly kování. Pokud byste reklamovali jiný díl  
nábytku, obraťte se přímo na svého prodejce nábytku.

**F** Bien étudier la notice de montage  
S'il vous manque une ferrure, veuillez envoyer directement la présente  
carte service à l'adresse e-mail indiquée ci-dessous. Cependant, ceci  
nous permet uniquement d'envoyer des ferrures. Pour tout autre type  
de réclamation concernant votre meuble, veuillez contacter  
directement votre magasin d'ameublement.

**I** Il nostro servizio diretto per l'ordine della ferramenta  
Qualora Vi dovesse mancare un pezzo di fissaggio, allora Vi  
preghiamo di inviare questa carta di servizio immediatamente  
all'indirizzo sottostante. Possiamo inviare i pezzi di fissaggio  
solamente per mezzo di questo procedimento. Qualora dovete  
avere qualche altra reclamazione in merito al mobile, allora Vi  
preghiamo di rivolgerVi direttamente al Vostro Negozio di mobili.

**BG** Нашата директна услуга за обкови  
Ако липсват части от комплекта, попълнете настоящата  
сервисна карта и ни я изпратете на e-mail адреса, посочен  
по-долу. По този начин можем да доставяме само липсващи  
елементи от обкова. Ако установите други дефекти по  
мебелите, Ви съветваме да се обърнете към мебелната  
къща/магазин, от който сте закупили стоката.

**NL** Onze directservice voor losse onderdelen  
Wanneer er een onderdeel ontbreekt, kunt u deze servicekaart  
direct aan onderstaand e-mailadres sturen. Wij kunnen langs deze  
weg echter alleen beslagdelen versturen. Mocht u een ander  
probleem aan uw meubel hebben, verzoeken wij u contact op te  
nemen met uw meubeldealer.

**PL** Nasz bezpośredni serwis czeszcí montazowych  
Jeżeli brakuje czeszcí koniecznych do montażu, prosimy o przesłanie  
nam niniejszej karty serwisowej na niżej podany adres e-mailowy.  
W ten sposób możemy przesłać Państwu tylko brakujące czeszcí.  
W przypadku innych reklamacji dotyczących mebla, prosimy zgłosić  
się do salonu meblowego, w którym został dokonany zakup.

**HR** Servis za okove  
U slučaju da nedostaje neki od dijelova molimo vas da na dolje  
navedenu mail adresu pošaljete ovaj servisni obrazac. Na ovaj način  
mogu se dostaviti samo okovi. U slučaju da imate dodatne prigovore  
vezane uz komad namještaja molimo vas da se obratite izravno  
trgovini namještaja gdje je isti kupljen.

**HU** Direktszolgáltatunk vasalattal eseten  
Ha hiányzik egy vasalat, ezt a kártyát közvetlenül elküldheti az  
alább található címre. Azonban csakis vasalattokat tudunk így  
küldeni. Amennyiben másfajta reklamáció áll fenn bútorárbaját  
illetően, forduljon közvetlenül a bútorházhöz.

**SK** Náš priamy servis pre časti kovania  
Ak by Vám chýbala nejaká časť kovania, môžete poslať  
túto servisnú kartu pošlou e-mailom na nižšie uvedenú  
adresu. Diely kovania vieme poslať iba týmto spôsobom.  
Ak by ste mali inú reklamáciu oľhadom Vášho nábytku,  
obraťte sa priamo na Vašu predajňu nábytku.

**SLO** Náše direktno uslužne storitve za okovje  
Če vam manjka kakšno okovje, lahko to servisno kartico pošljete  
po e-pošti direktno na spodnji naslov. Po tej poti vam lahko  
pošljemo samo okovje. Če želite reklamirati kakšen drug del  
pohištva, se obrnite neposredno na vašo trgovino pohištva.

**RO** Service-ul nostru direct pentru feronerie  
În cazul în care vă lipsește o piesă de feronerie puteți să trimiteți  
direct acest card de service prin e-mail la adresa de mai jos. Noi  
nu putem expedia piese de feronerie decât pe această cale.  
Dacă aveți o altă reclamație referitoare la piesa de mobilier,  
atunci vă rugăm să vă adresați direct la magazinul dvs. de mobilă.

**RUS** Наш прямой сервис для поставок фурнитуры  
Если окажется, что Вам не хватает того или иного элемента  
фурнитуры, Вы можете отправить сервисную карту по факсу  
непосредственно на нижеприведенный адрес электронной  
почты. Однако, таким образом мы можем пересылать лишь  
фурнитуру. Если же у Вас возникнут иные претензии относительно  
приобретенной мебели, пожалуйста, обращайтесь  
непосредственно в организацию, осуществившую продажу.

**S** Vår direktservice för beslagsdelar  
Om du saknar en beslagsdel kan du skicka detta servicekort direkt  
till e-postadressen som anges nedan. Tänk på att detta är den enda  
möjligheten att skicka beslagsdelar till dig. Om du vill reklamera din  
möbel av en annan anledning måste du kontakta ditt möbelhus direkt.

**ES** Nuestro servicio directo para accesorios  
Si le falta algún accesorio, puede enviar esta tarjeta de servicio directamente  
a la siguiente dirección. No obstante, por este método solo podemos  
enviar accesorios. Si tiene alguna otra objeción sobre su mueble, consulte  
directamente con su mueblería.

**TR** Donatılar için doğrudan servisimiz  
Bir donatınız eksikse bu servis kartını doğrudan aşağıda bulunan adrese  
doğrudan mail yazabilirsiniz. Sadece bu yolla donatılar gönderilebilir.  
Mobilyanızda başka şikayetleriniz varsa lütfen doğrudan mobilya satıcınıza  
danışın.

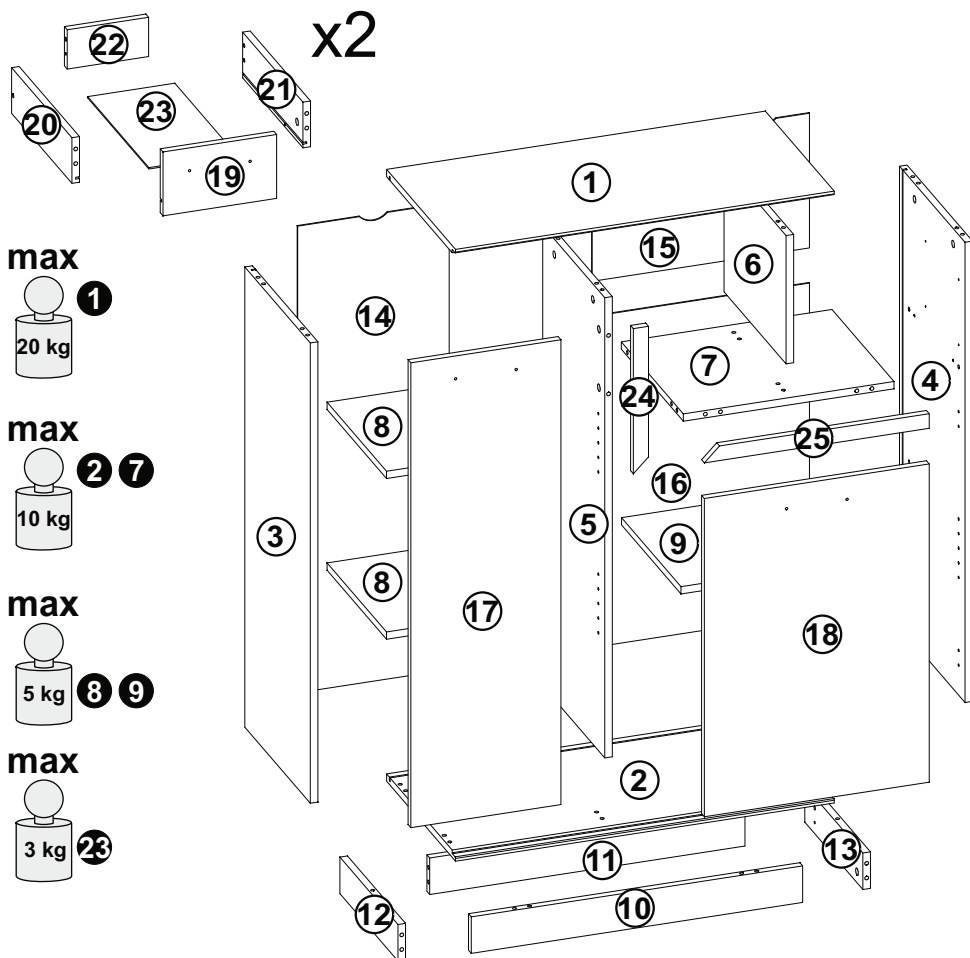

1	800	400	16	x1	1/2
2	800	400	16	x1	1/2
3	1008	380	16	x1	2/2
4	1008	380	16	x1	2/2
5	1008	360	16	x1	2/2
6	281	360	16	x1	1/2
7	445	360	16	x1	1/2
8	305	345	16	x2	1/2
9	444	345	16	x1	1/2
10	700	80	16	x1	1/2

11	666	80	16	x1	1/2
12	337	80	16	x1	1/2
13	337	80	16	x1	1/2
14	1022	320	3	x1	2/2
15	295	459	3	x1	1/2
16	725	459	3	x1	1/2
17	1018	317	16	x1	2/2
18	697	475	16	x1	1/2
19	240	140	16	x2	1/2
20	350	100	16	x2	1/2

21	350	100	16	x2	1/2
22	172	86	16	x2	1/2
23	184	355	3	x2	1/2
24	318	32	16	x1	1/2
25	475	32	16	x1	1/2

Grund der Beanstandung / Cause for complaint:

---

Möbelhaus / Furniture store:

---

Kunde / Customer: \_\_\_\_\_ Telefon / Telephone: \_\_\_\_\_

---

PLZ / Postcode: \_\_\_\_\_ Ort / City: \_\_\_\_\_

---

Str.+Nr. / Street address \_\_\_\_\_

---

@E-Mail: \_\_\_\_\_

LKZ 80236

Modellname / Model name / Nom du modèle / Modellnamn  
Nome modello / Název modelu / Modelnaam / Ime modela  
Número Modelo / Modell neve / Название модели /  
Názov modelu / Ime modela / Denumire model /  
Наименование на модела / Nazwa modelu

**Synnax**









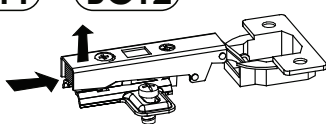

Modellnummer / Number / Numéro du modèle  
Numero / Номер на модела / modello  
Číslo modelu / Modell száma / Èíslo modelu  
Številka modela / Număr model / Broj modela  
Modelnummer / Numer modelu

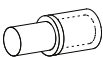
2134-866-84

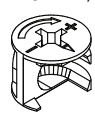
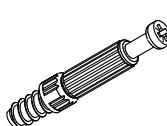
Type / Tipo / Tipus / Typ / Тип / Tip

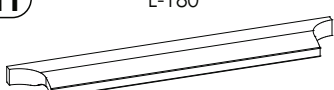
**866**

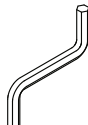
## B1 Colli 1/2

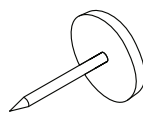
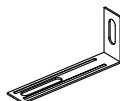
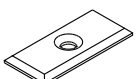
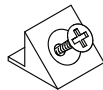
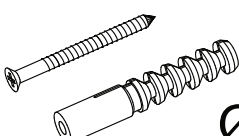
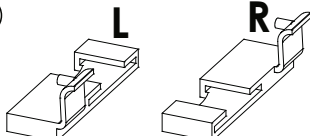
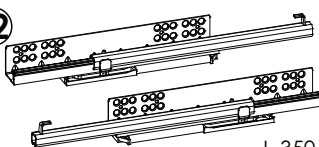
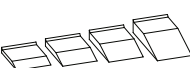
<b>A1</b> 8 x 35 x38 	<b>BC11 + BC12</b> x4 	<b>C2</b> 5x13 x16 
<b>D2</b> x12 	<b>E0</b> x16 	<b>E1</b> 15 x 12,5 x30 
<b>F1</b> x30 	<b>G0</b> x2 	<b>G1</b> 7 x 50 x12 
<b>H1</b> L-180 x4 	<b>I2</b> 4 x 16 x2 	<b>I5</b> 3,5 x 27 x8 
<b>M</b> x1 	<b>N1</b> 3 x 16 x15 	<b>O2</b> x6 
<b>Q9</b> x2 	<b>R1</b> x11 	<b>R4</b> x12 
<b>S13</b> x2  Ø8	<b>TZ</b> L R x2 	<b>T12</b> x2  L-350
	<b>Z</b> x1 	

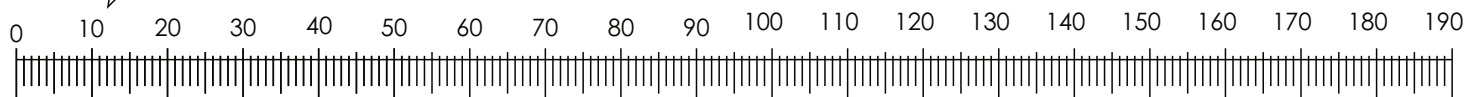
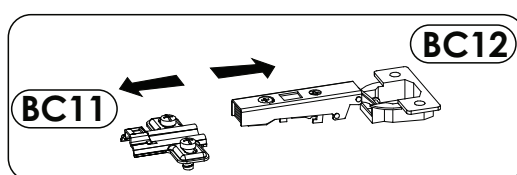
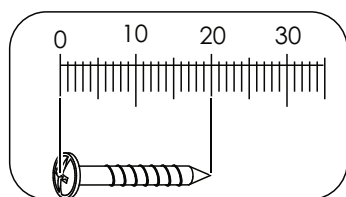

1

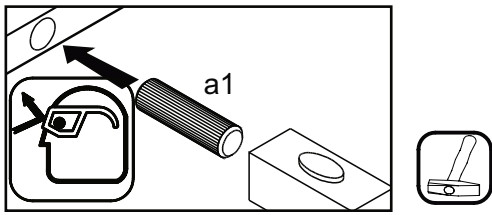
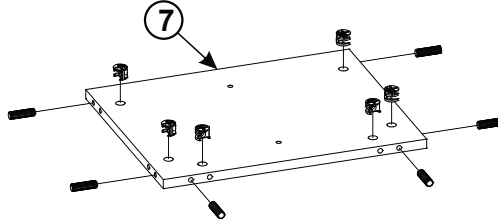
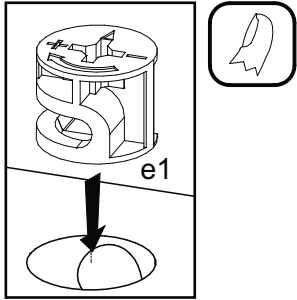
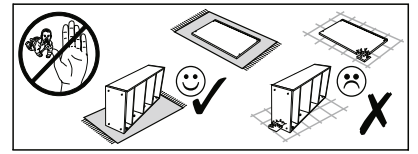
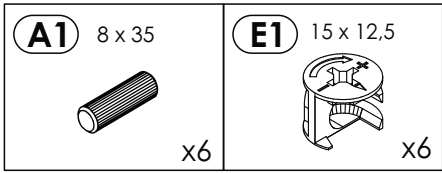

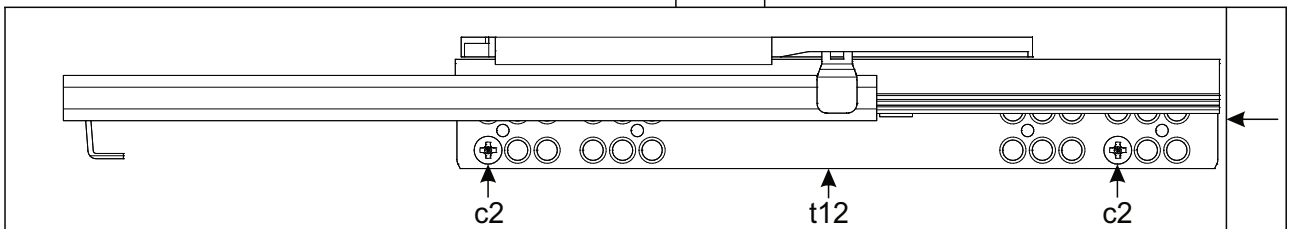
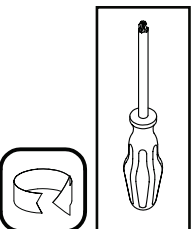
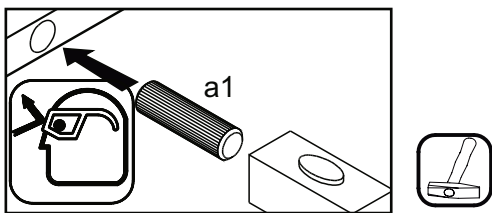
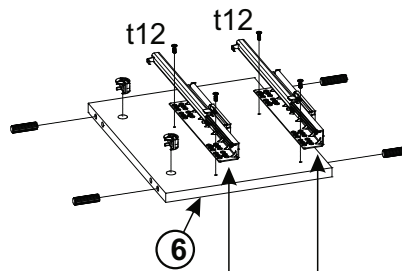
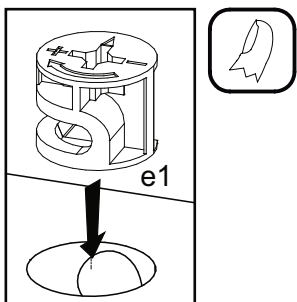
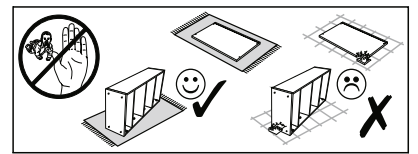
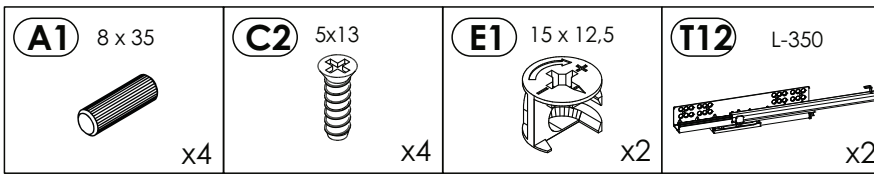

2

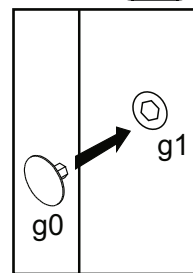
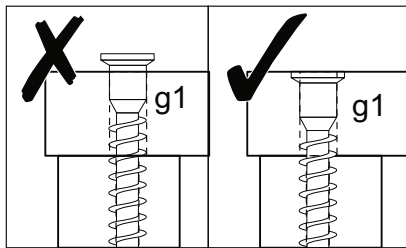
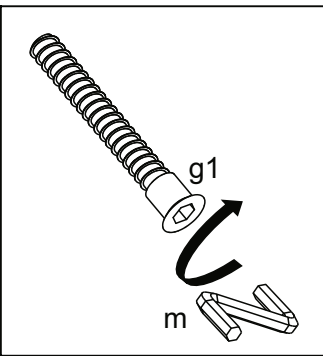
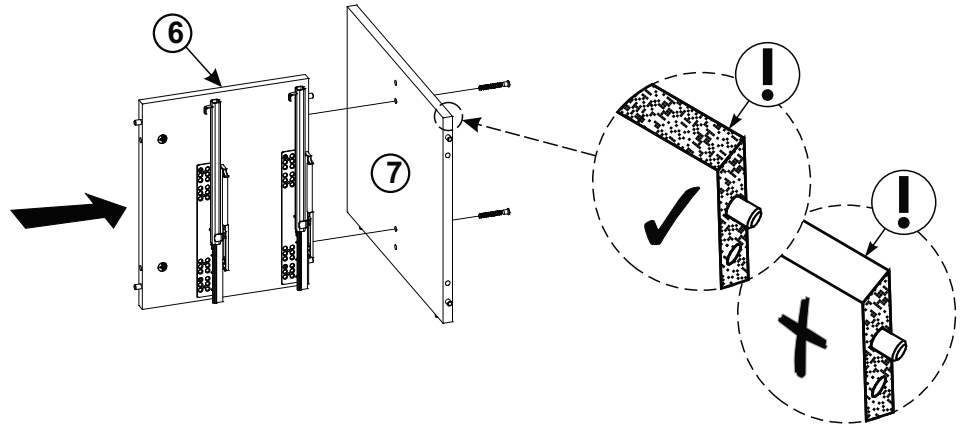
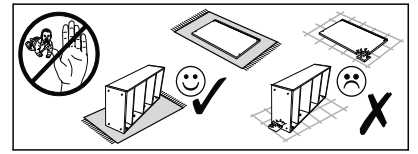
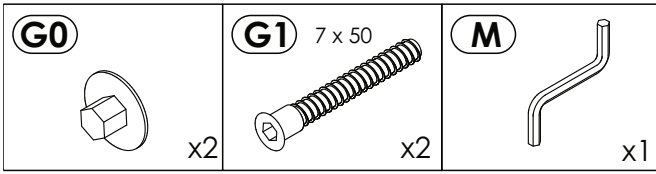

3

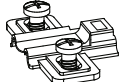

4

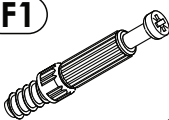
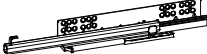
<b>A1</b> 8 x 35  x4	<b>BC11</b>  x2	<b>C2</b> 5x13  x4	<b>E1</b> 15 x 12,5  x2
<b>F1</b>  x2	<b>T12</b> L-350  x2		

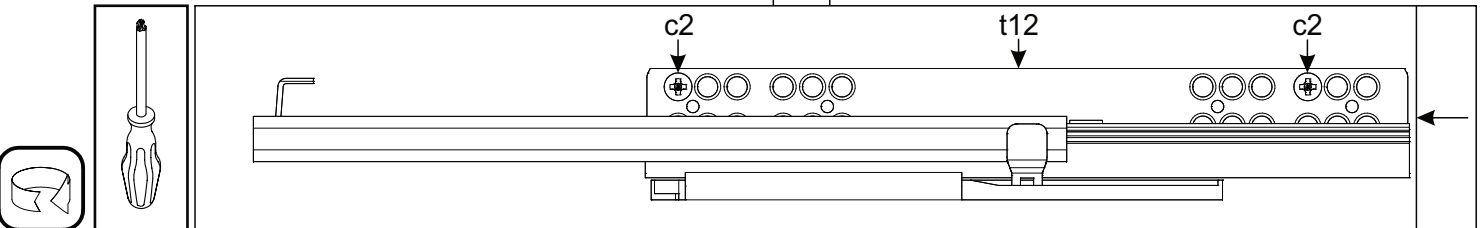
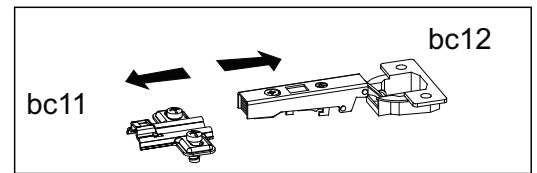
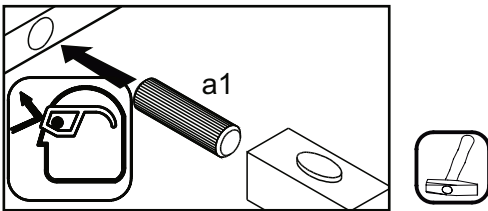
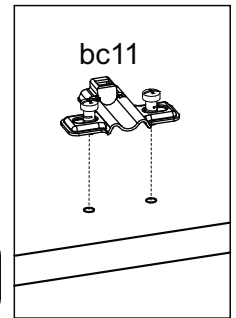
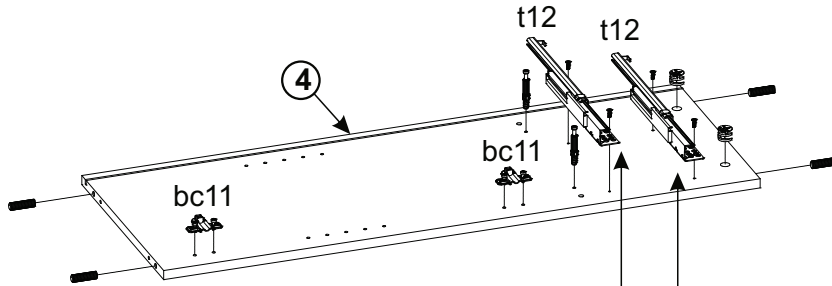
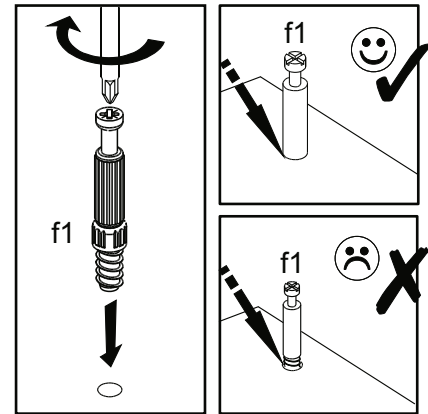
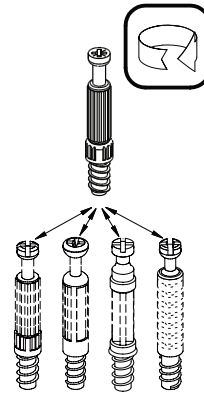
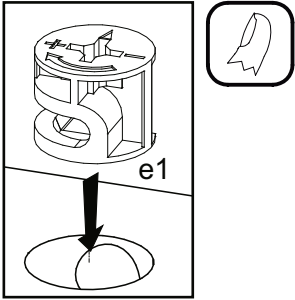
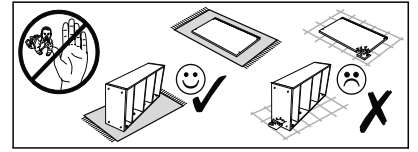

5

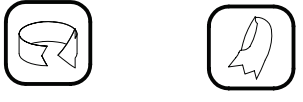
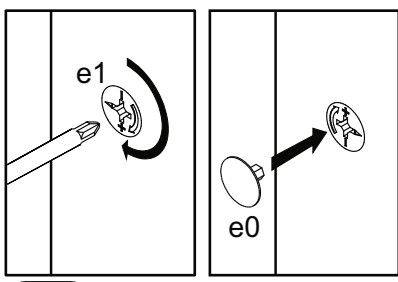
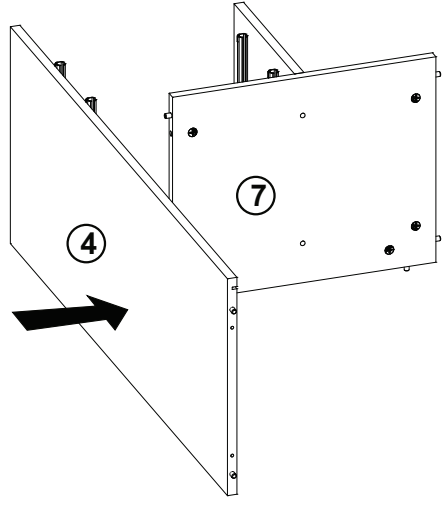
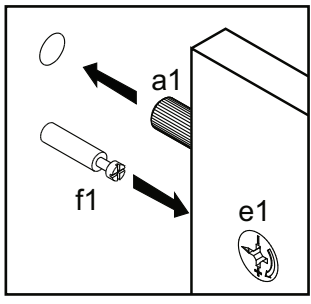
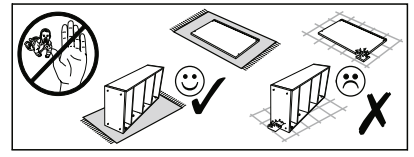
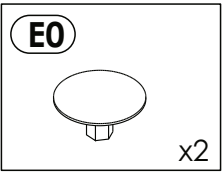

6

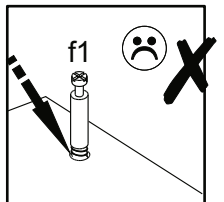
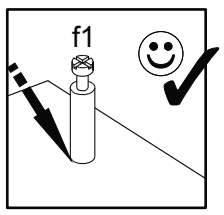
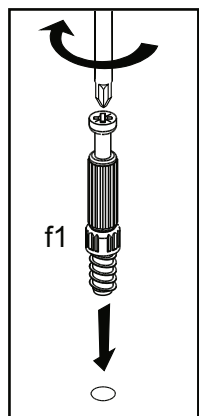
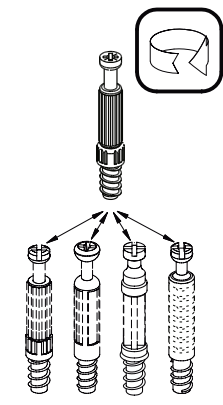
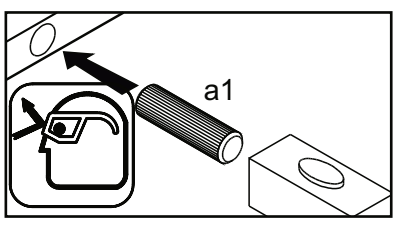
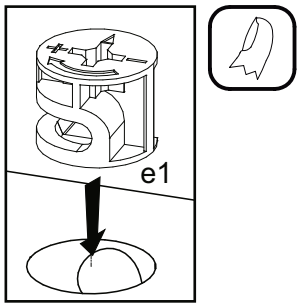
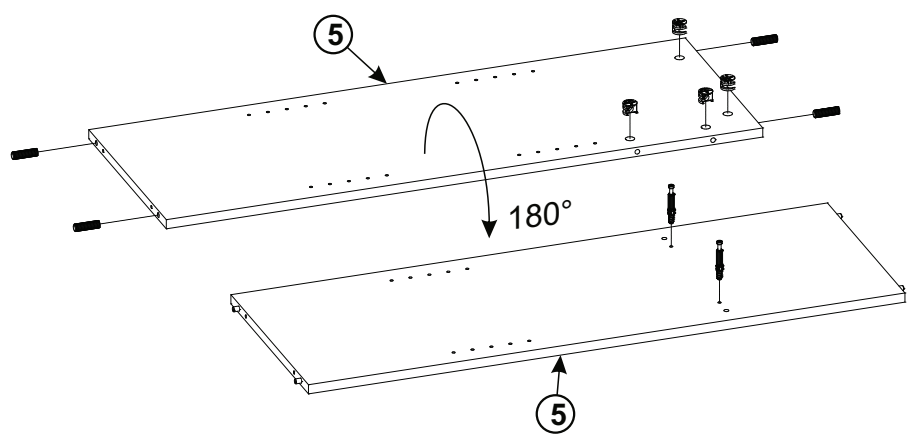
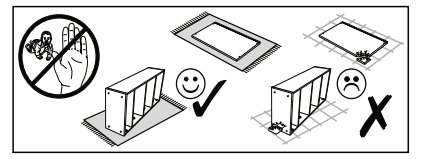
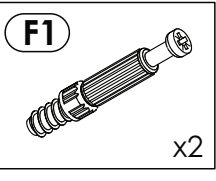
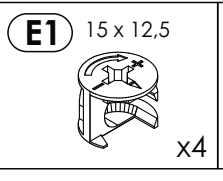
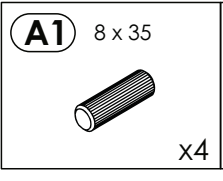



7

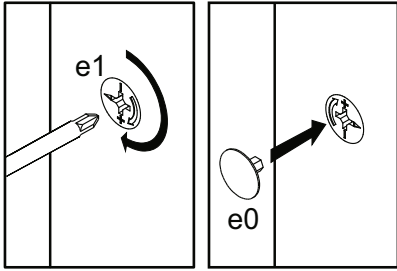
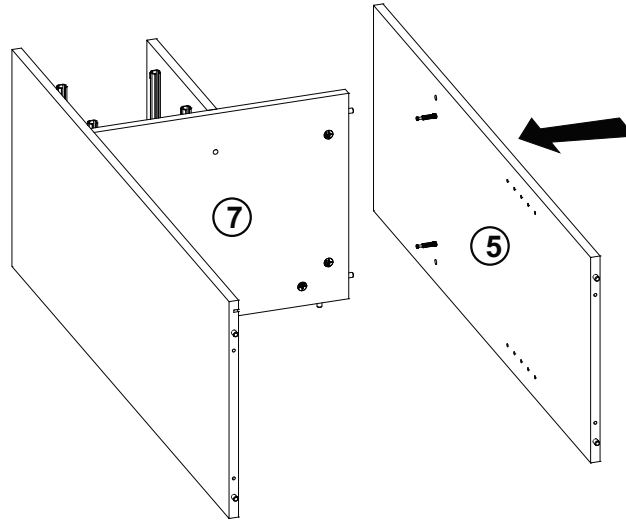
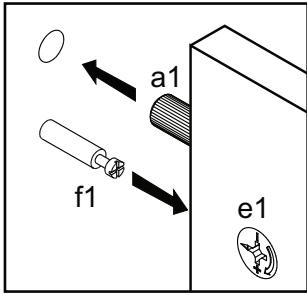
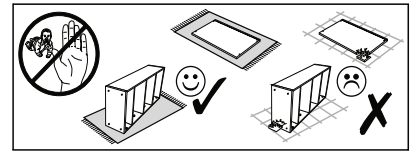
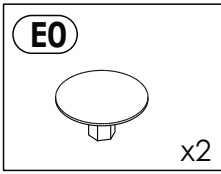

8

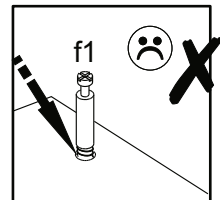
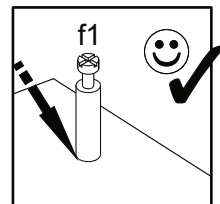
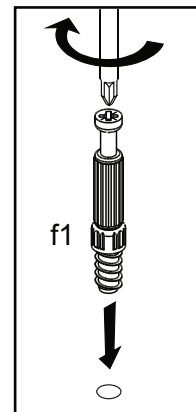
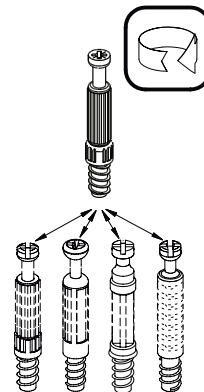
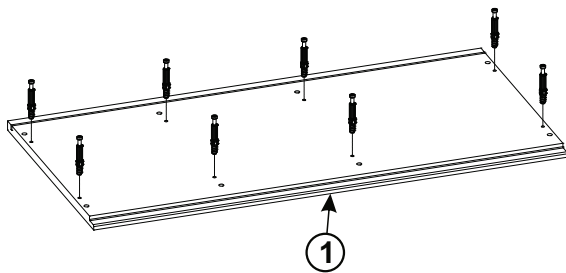
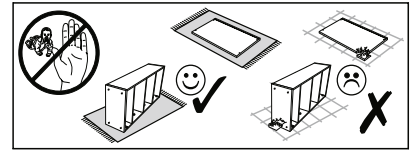
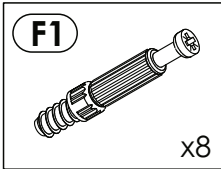

9

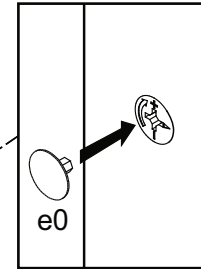
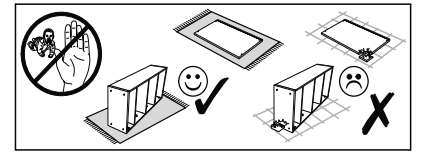
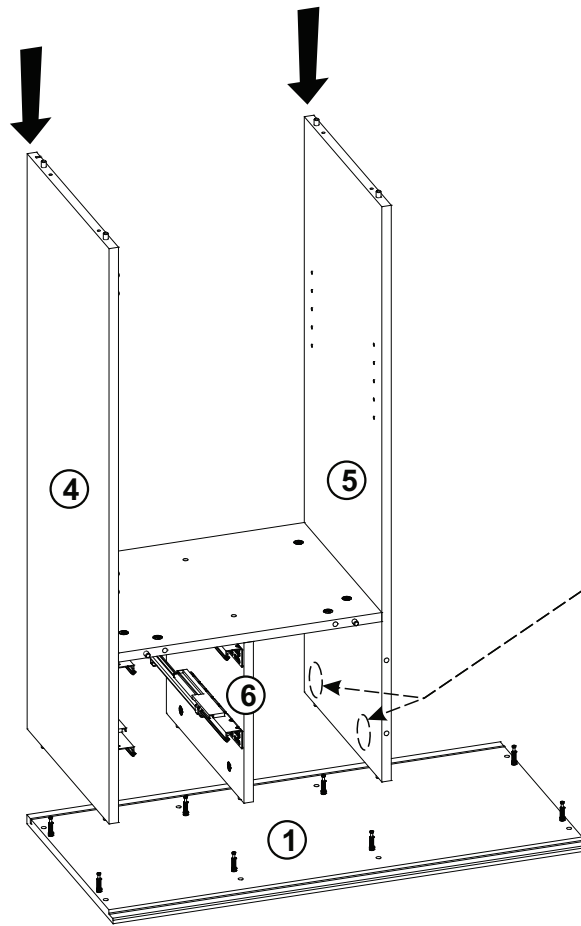
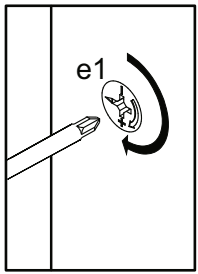
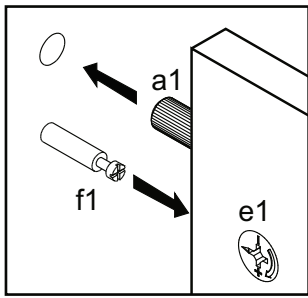
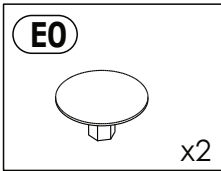

10

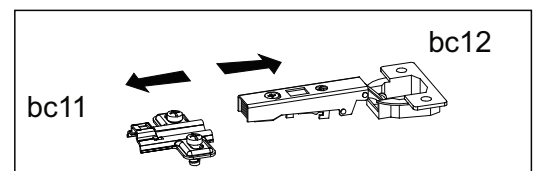
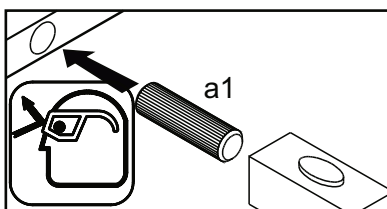
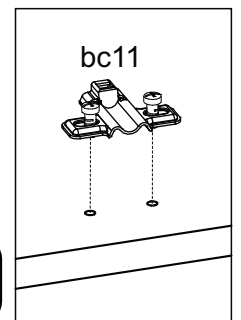
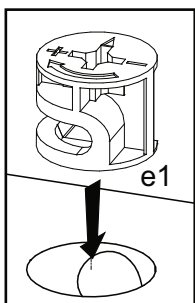
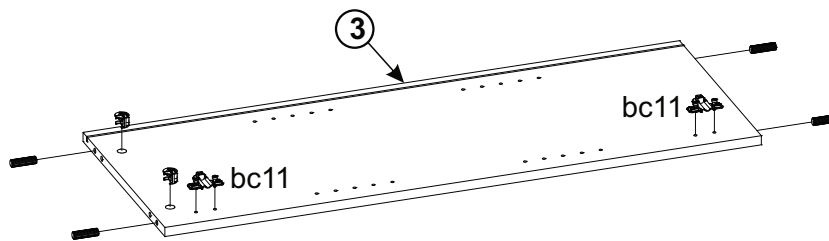
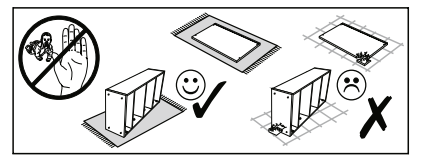
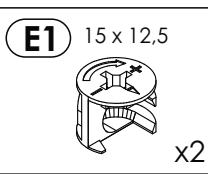
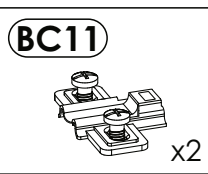
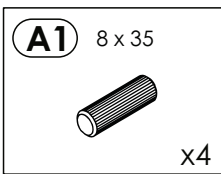

11

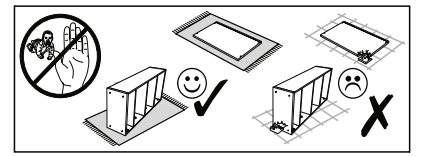
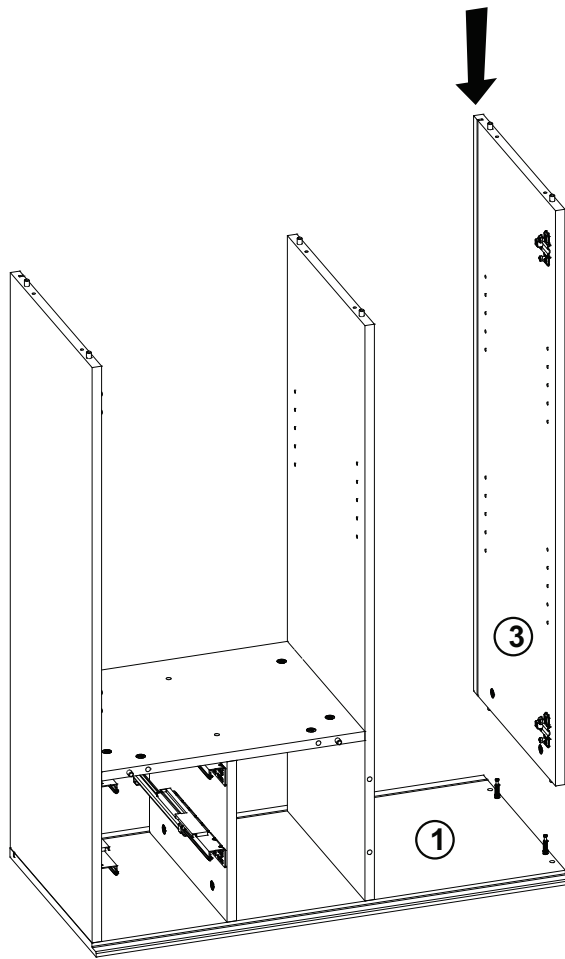
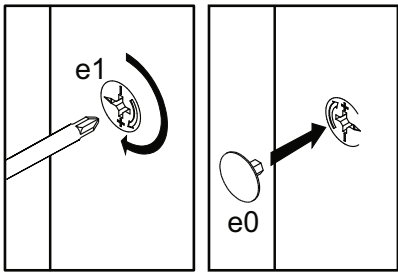
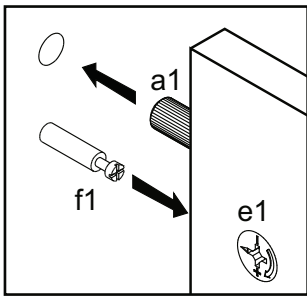
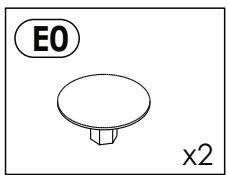

12

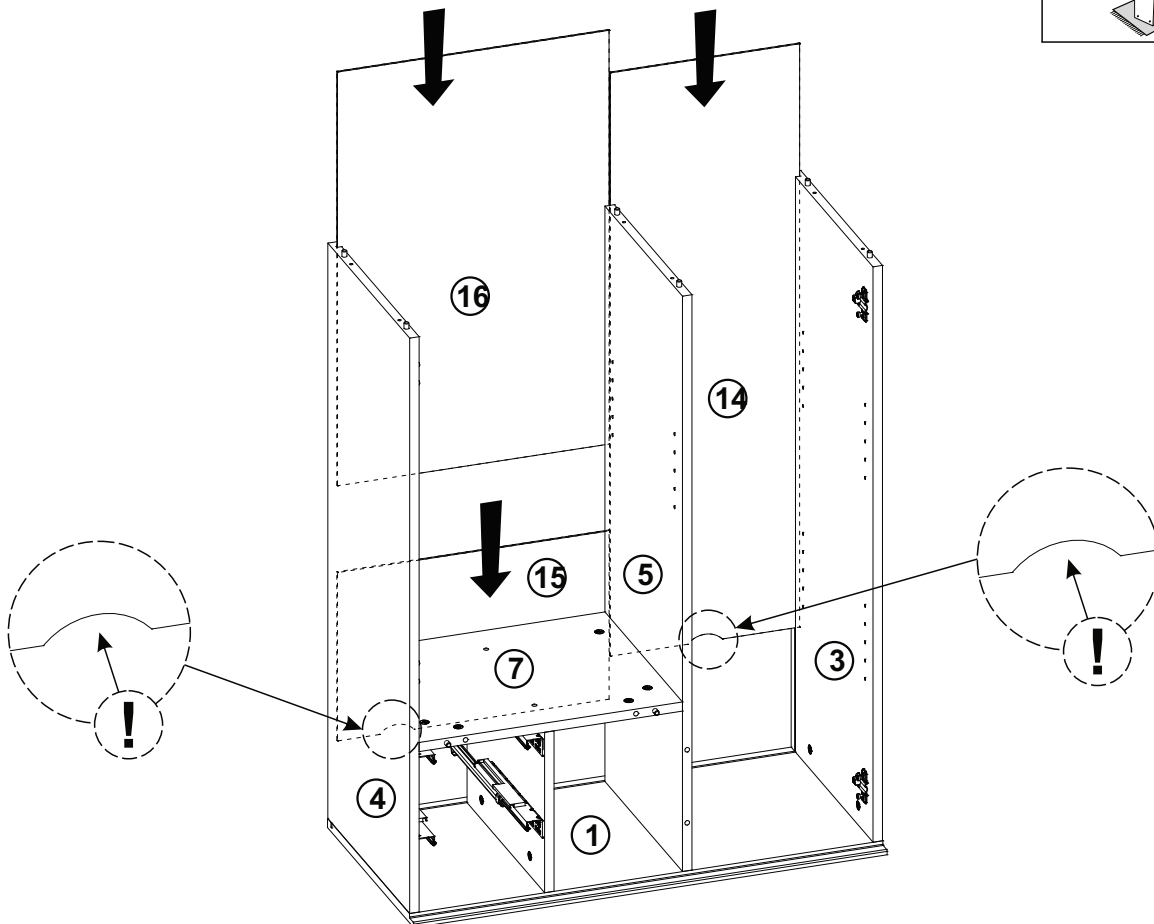
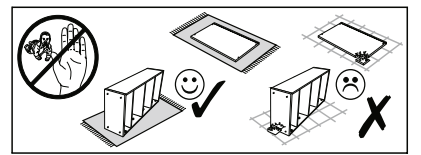

13

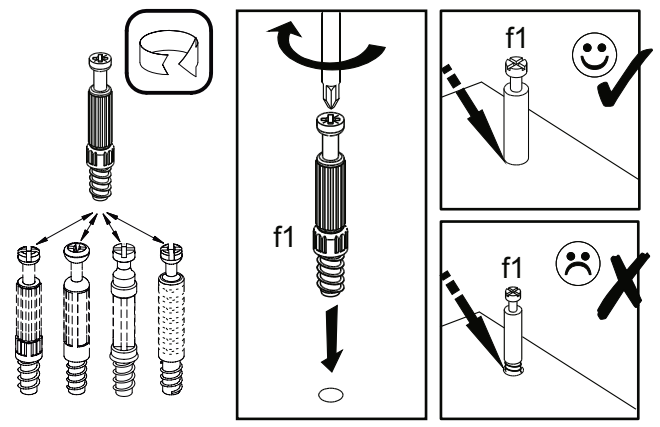
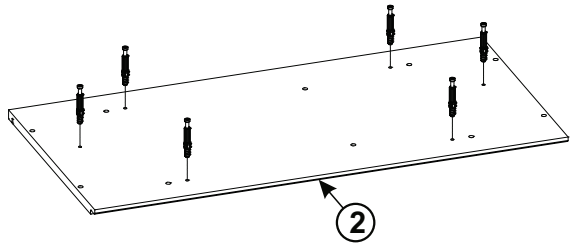
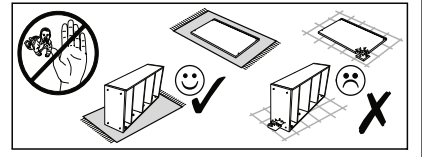
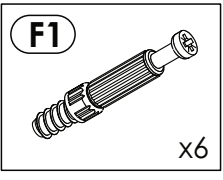

14

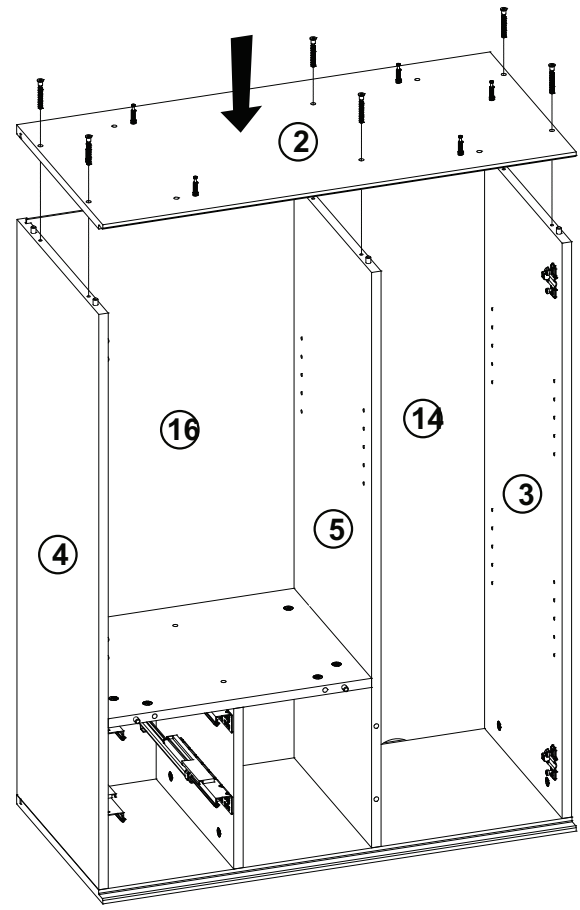
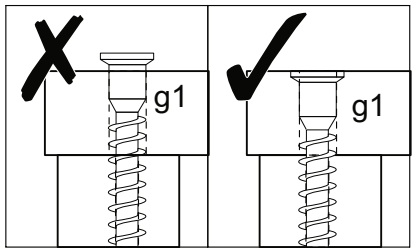
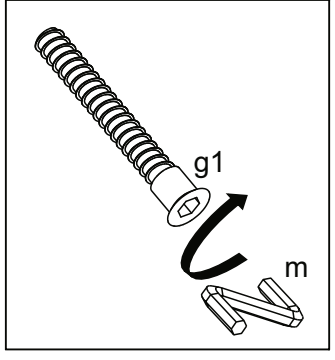
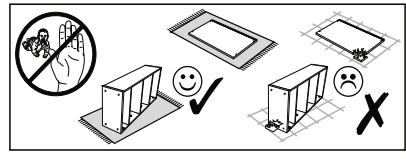
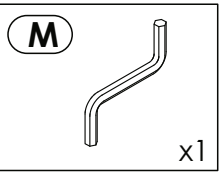
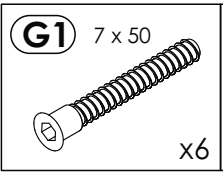

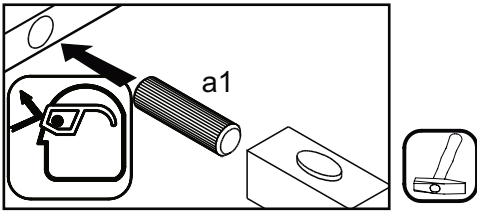
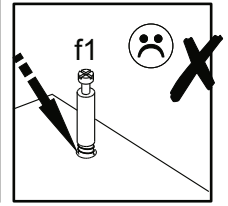
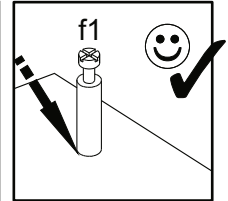
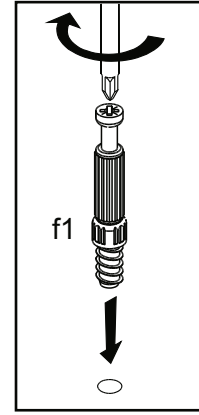
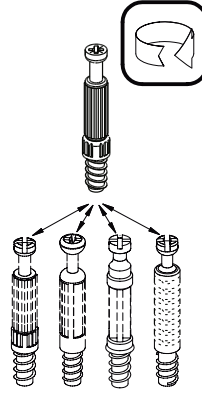
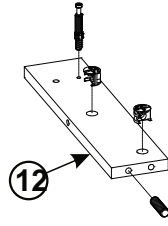
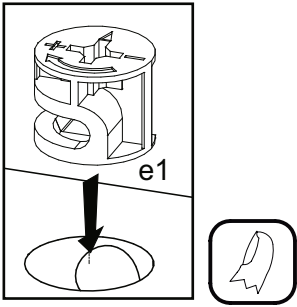
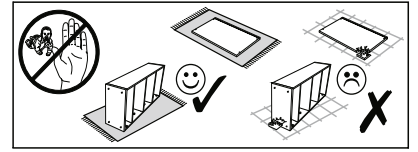
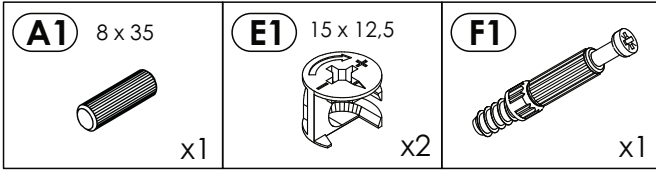

15

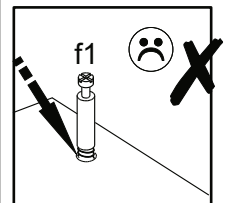
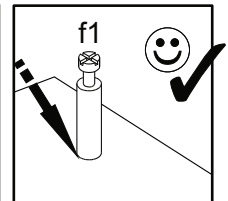
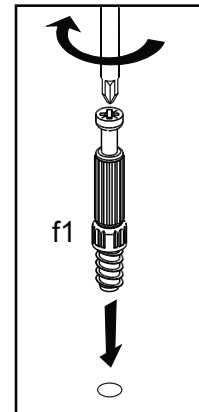
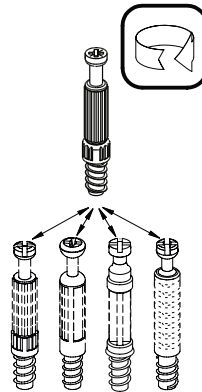
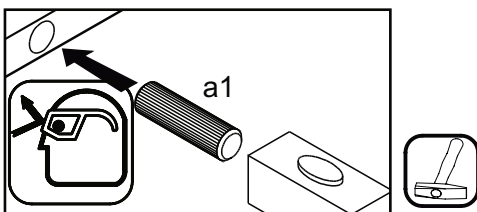
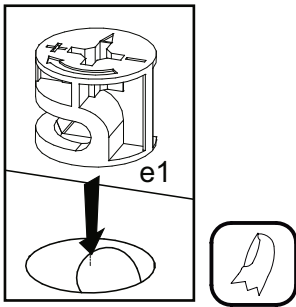
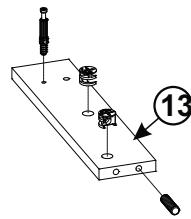
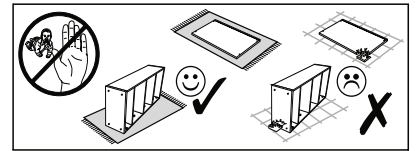
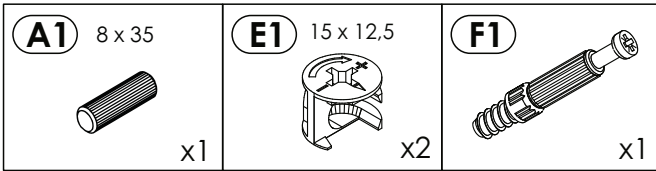

16



17

<p><b>A1</b> 8 x 35</p>  <p>x4</p>	<p><b>E1</b> 15 x 12,5</p>  <p>x4</p>
---------------------------------------------------------------------------------------------------------------------	------------------------------------------------------------------------------------------------------------------------

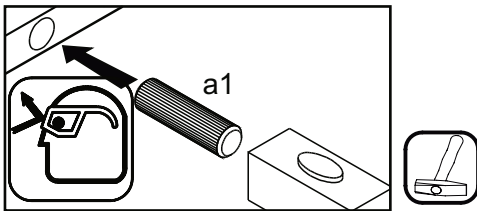
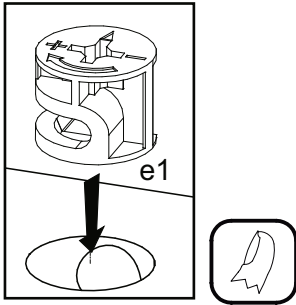
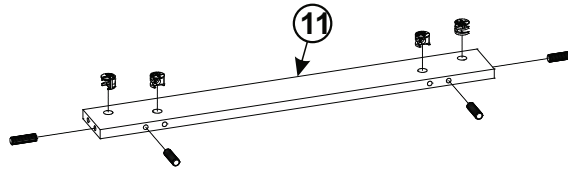
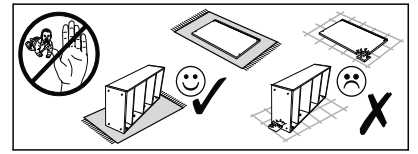

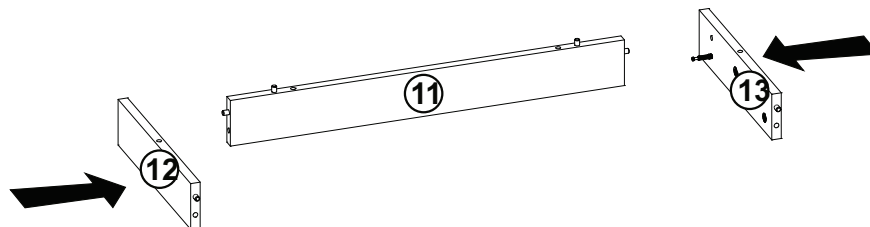
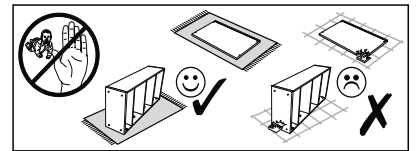

18

<p>f1</p>	<p>e1</p>
-----------	-----------

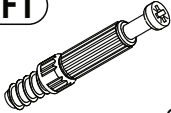

19

<p><b>A1</b> 8 x 35</p>  <p>x2</p>	<p><b>E1</b> 15 x 12,5</p>  <p>x2</p>	<p><b>F1</b></p>  <p>x2</p>
---------------------------------------------------------------------------------------------------------------------	------------------------------------------------------------------------------------------------------------------------	--------------------------------------------------------------------------------------------------------------

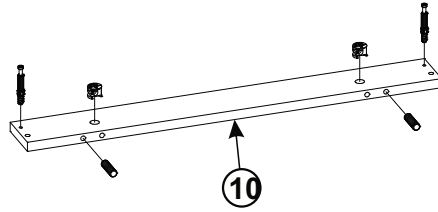
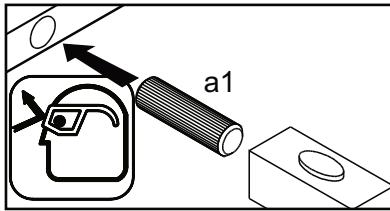
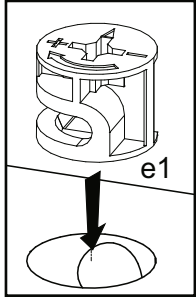
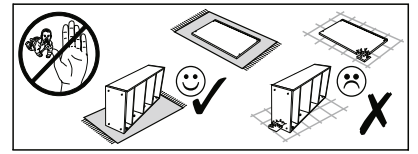

10

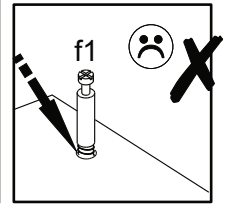
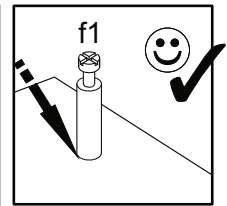
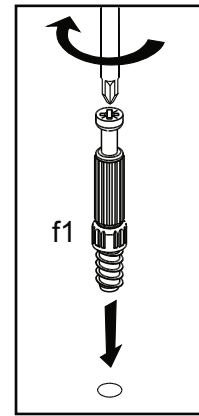
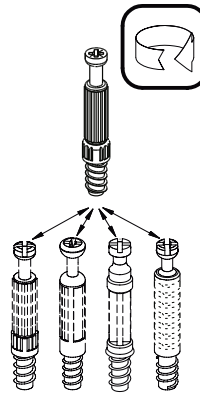

20

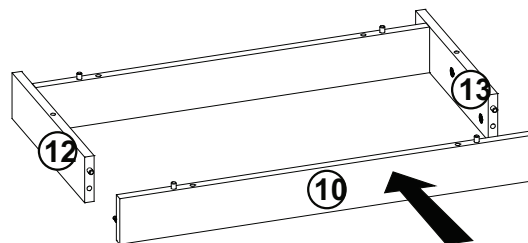
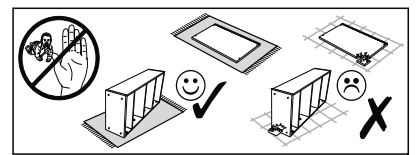
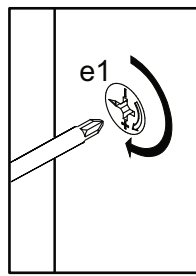
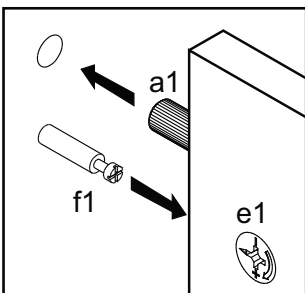

12

10

13

21

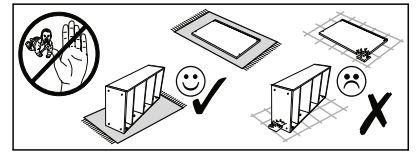
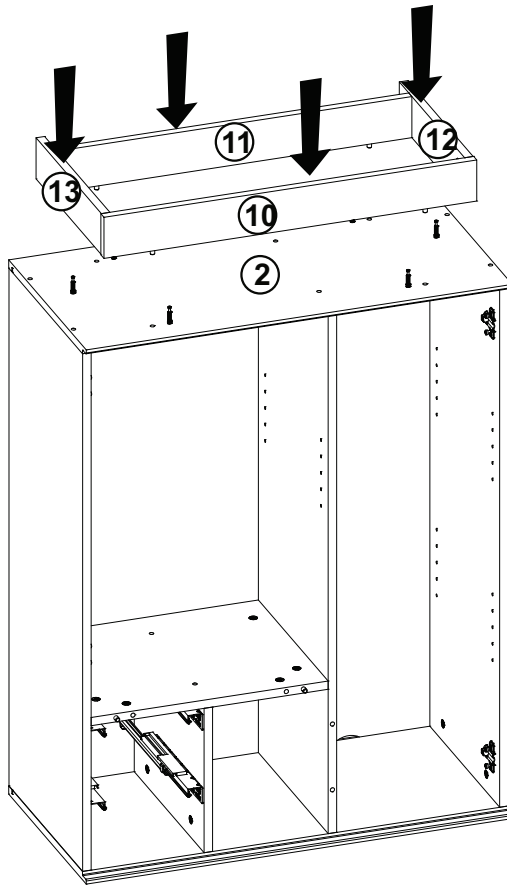
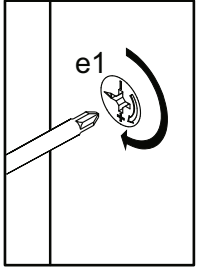
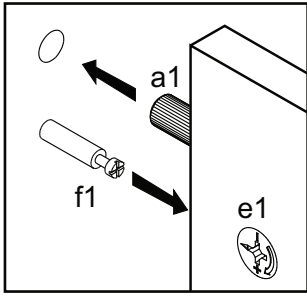

22

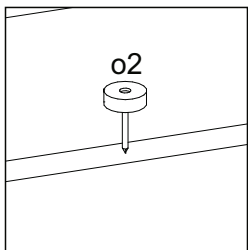
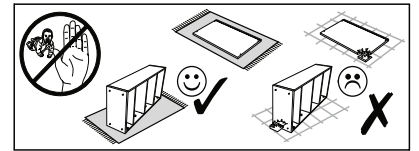
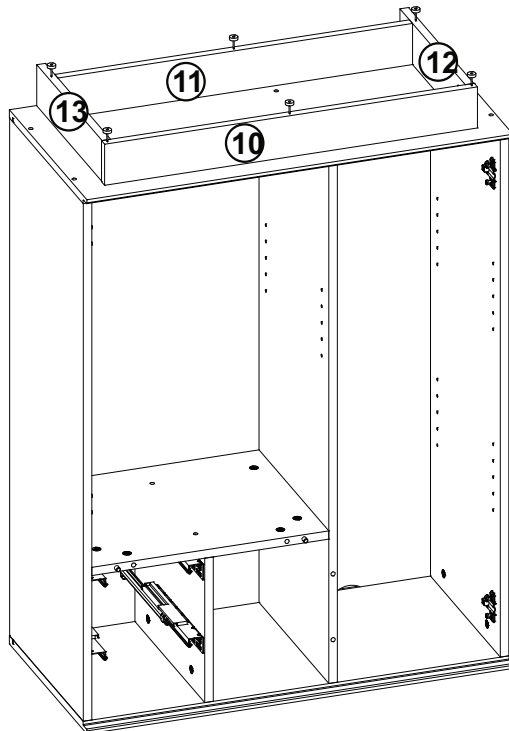
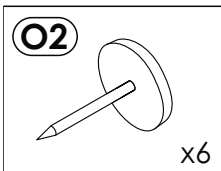



23



A=B

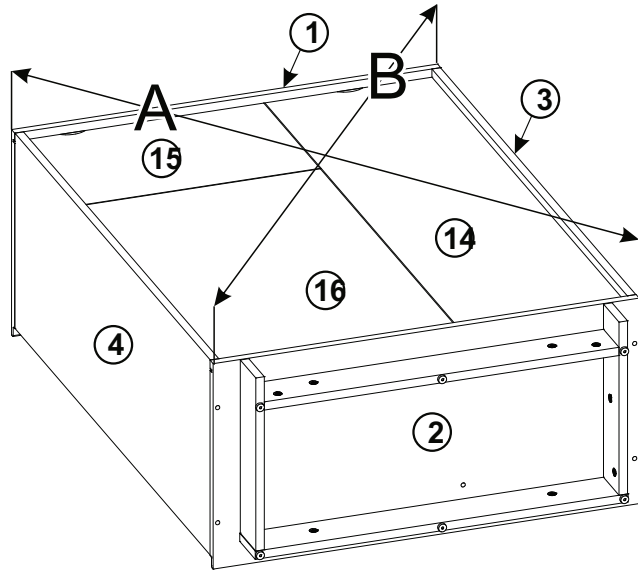
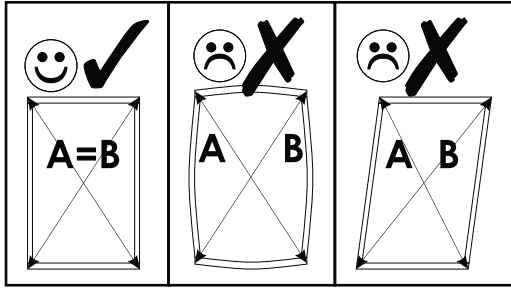
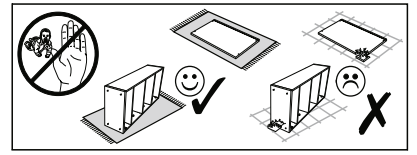

24

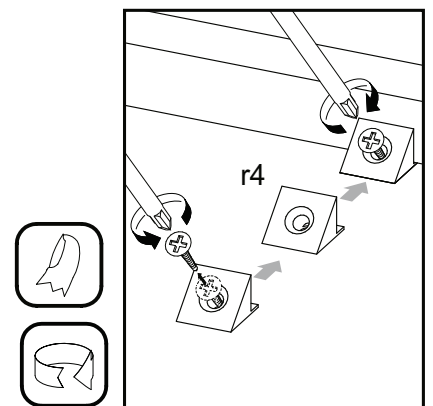
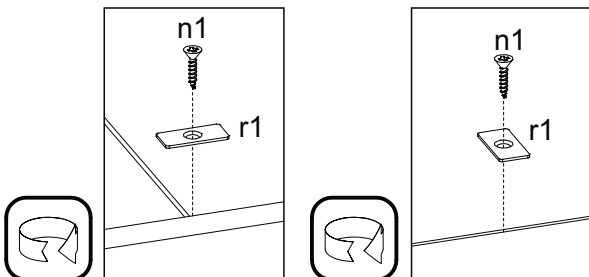
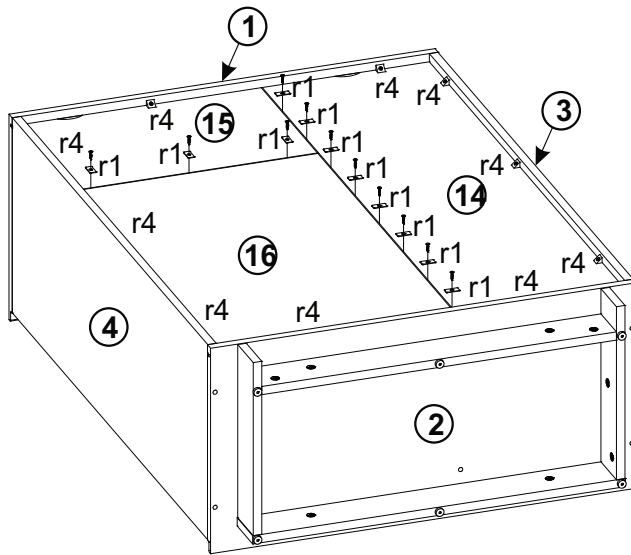
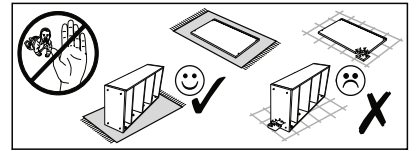
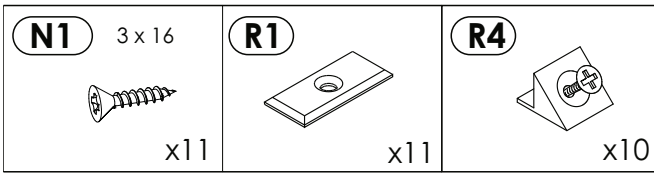

25

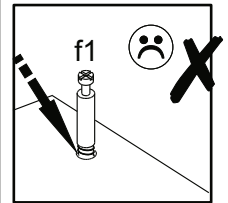
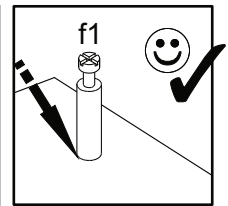
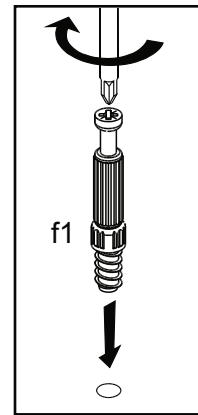
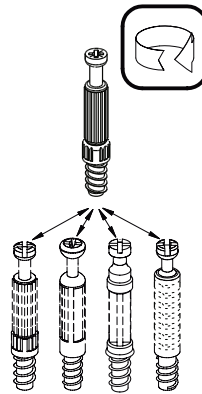
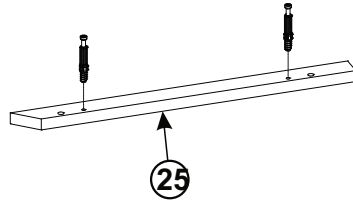
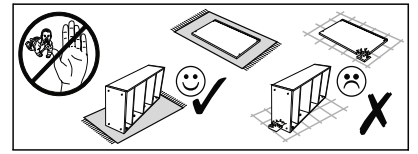
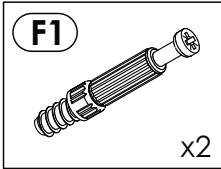

26

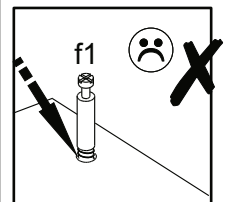
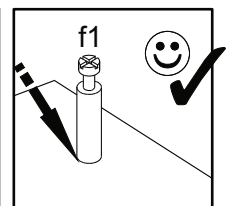
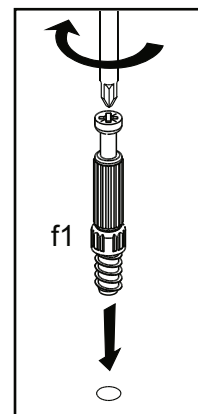
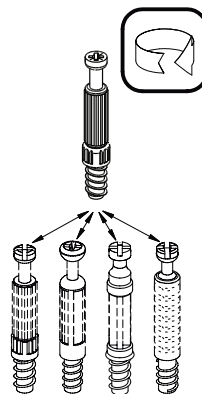
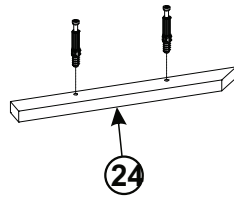
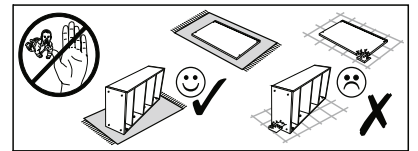
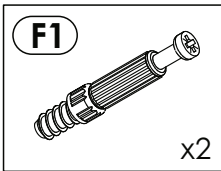

27

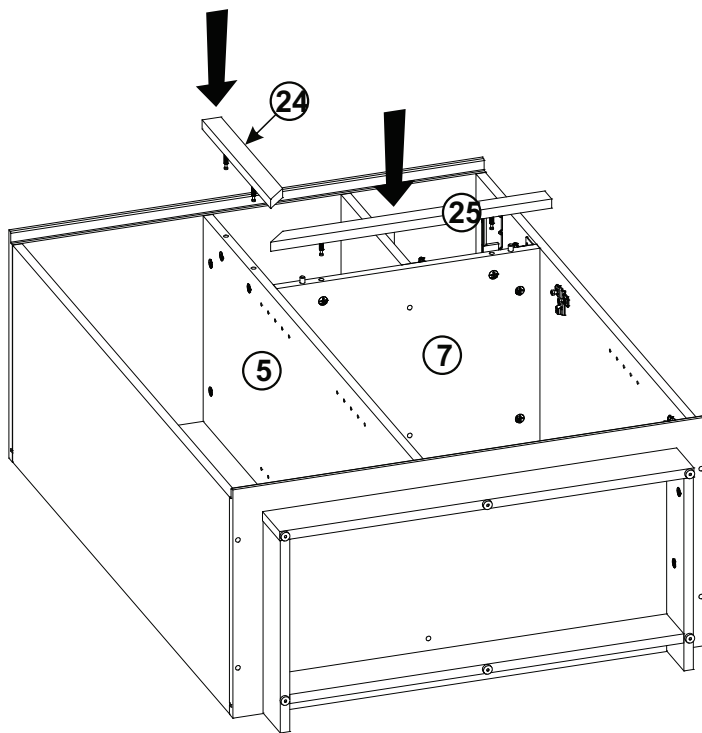
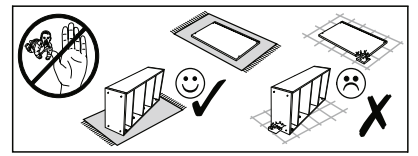
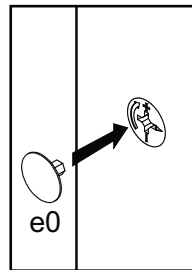
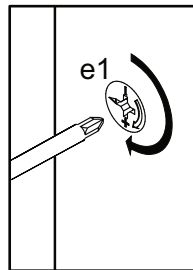
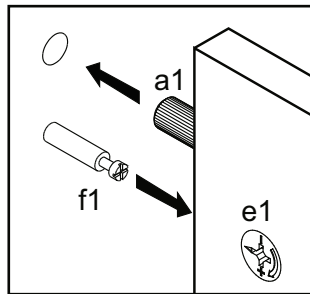
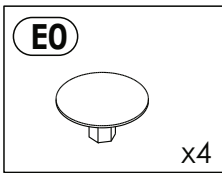

28

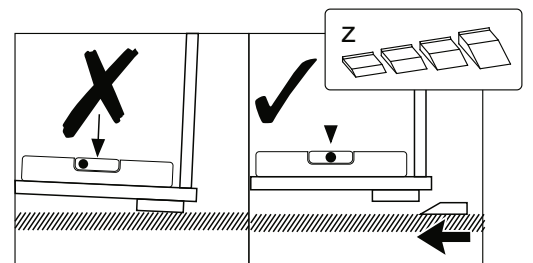
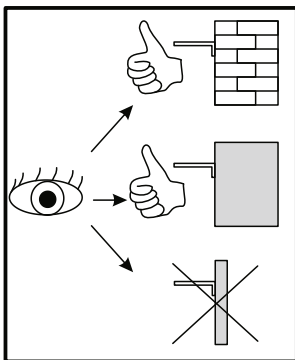
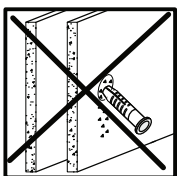
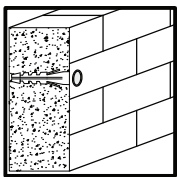
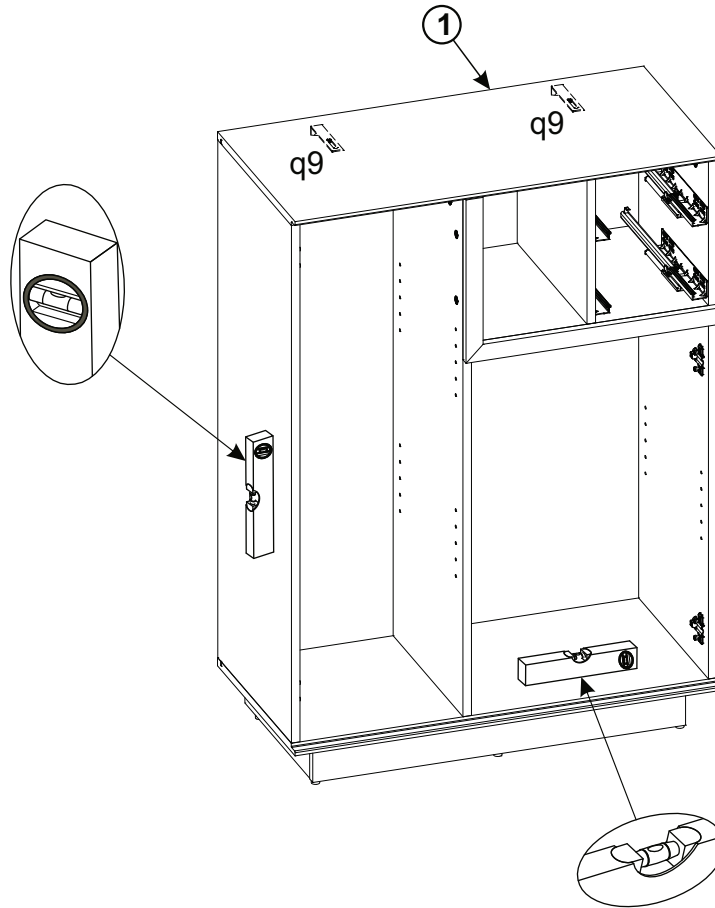
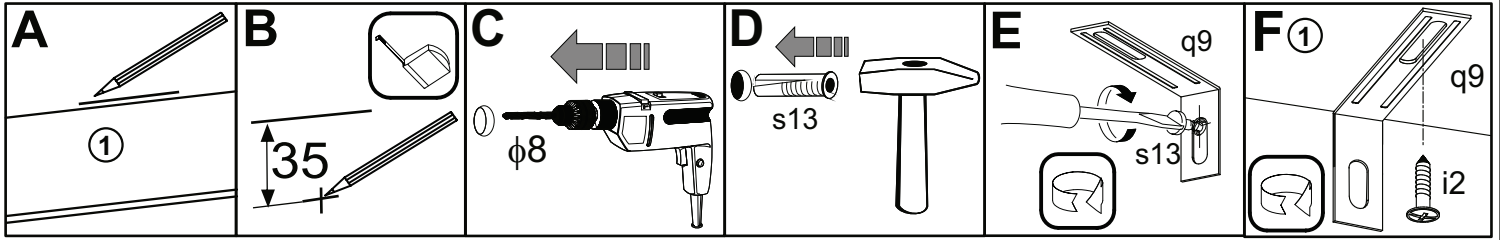
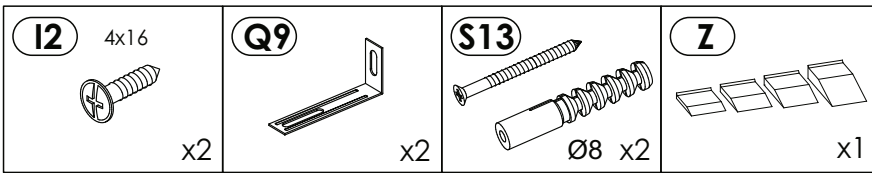

29

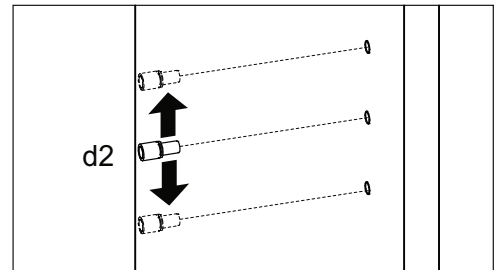
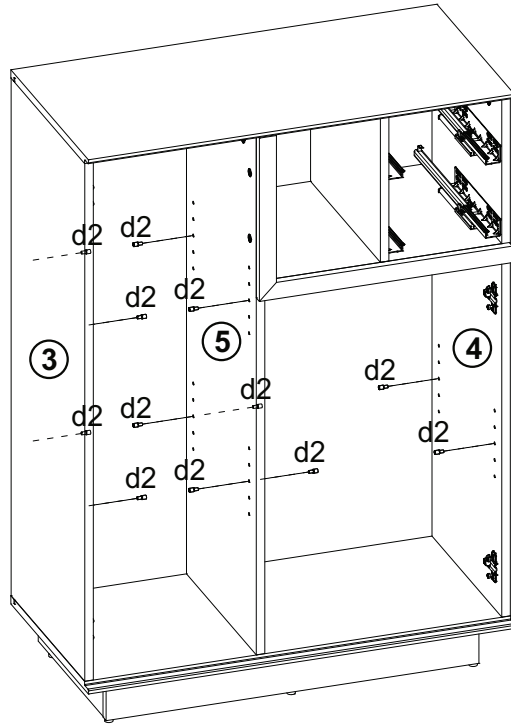
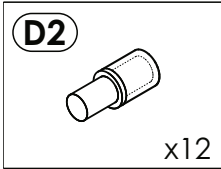

30

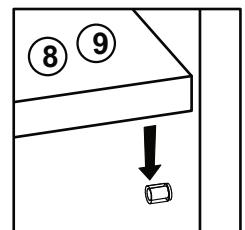
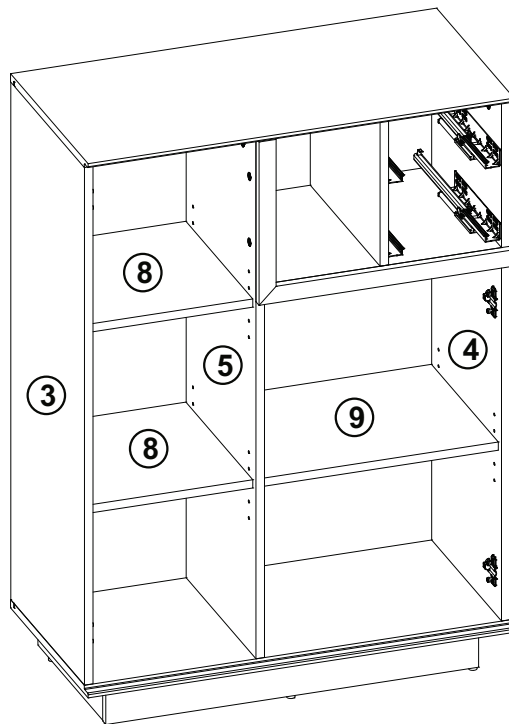

31

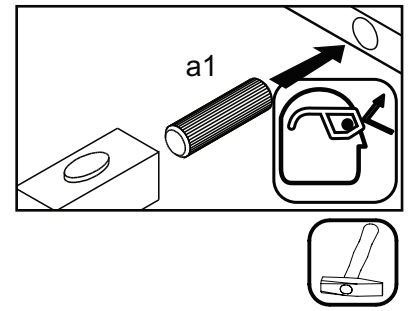
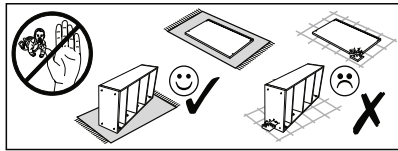
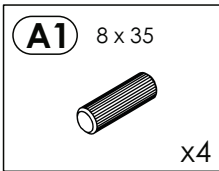

32

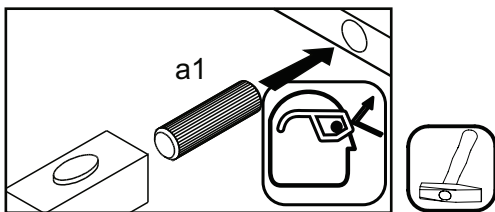
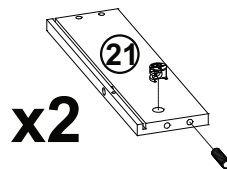
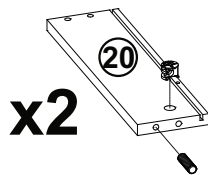
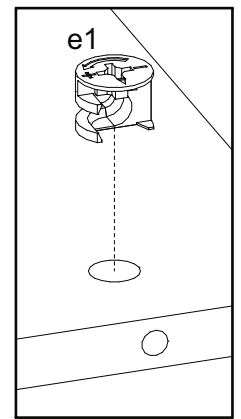
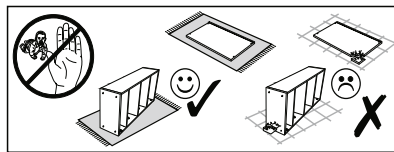
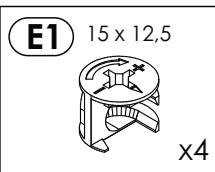
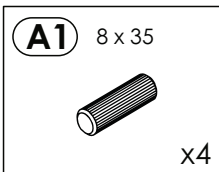

33

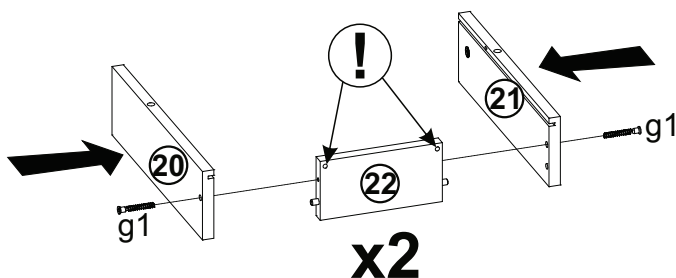
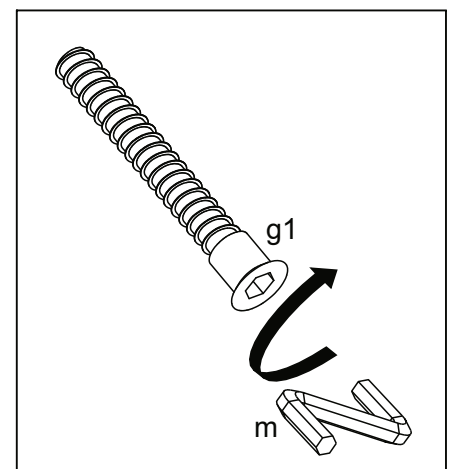
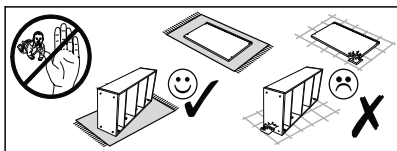
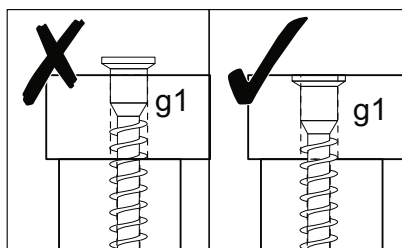
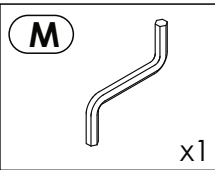
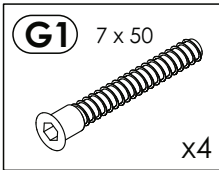

34

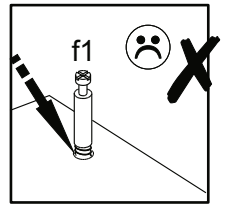
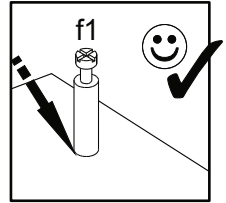
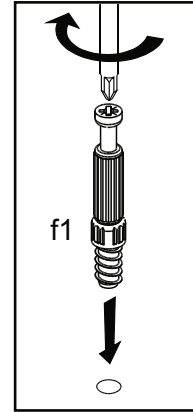
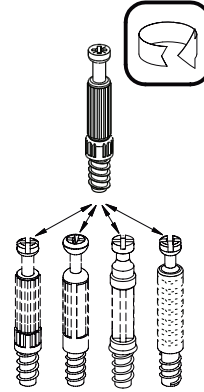
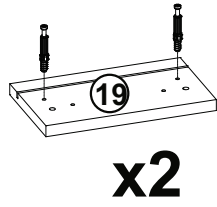
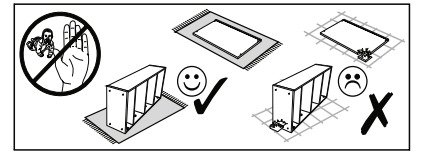
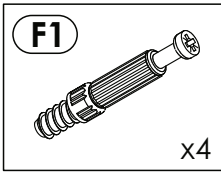

35

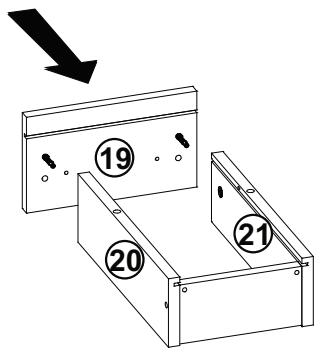
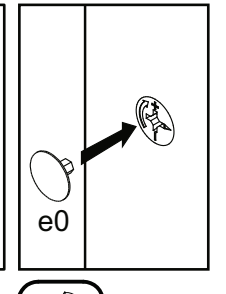
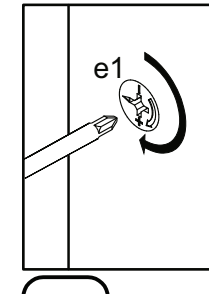
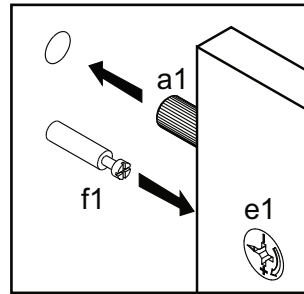
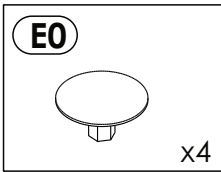

x2

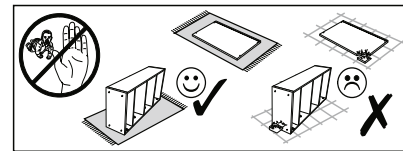

36

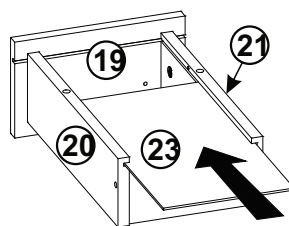
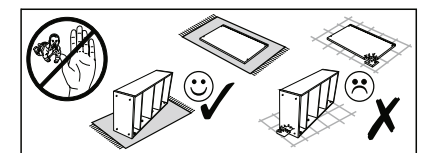

x2

37



C=D

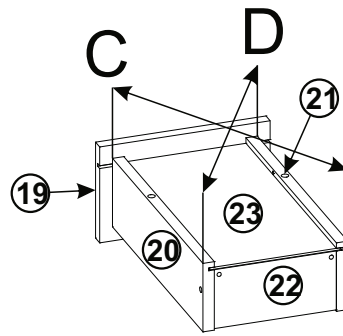
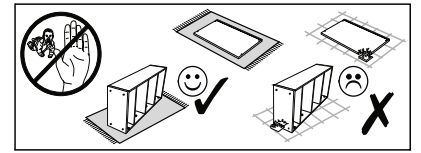

x2

38

N1 3 x 16



x4

R4

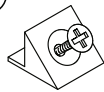

x2

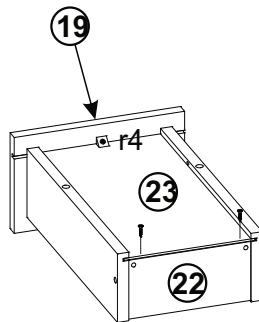
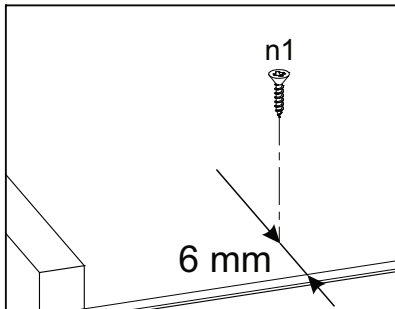
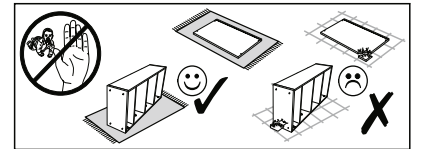

x2

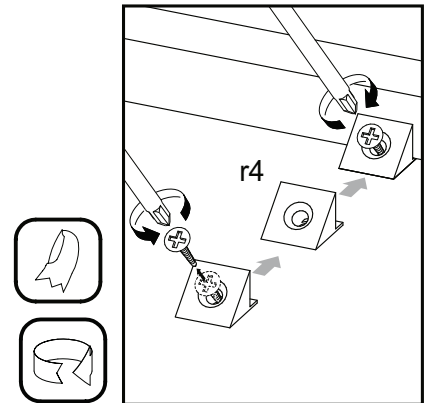

39

H1 L-180



x2

I5 3,5 x 27



x4

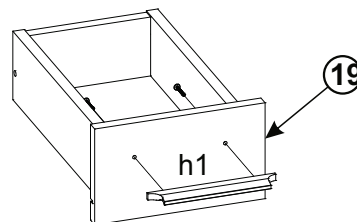
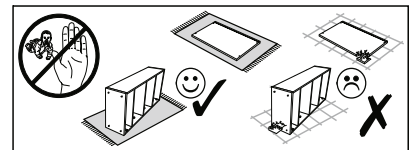

x2

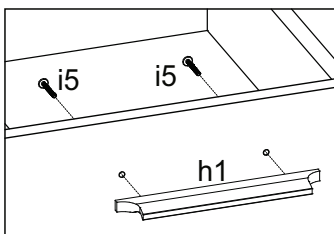



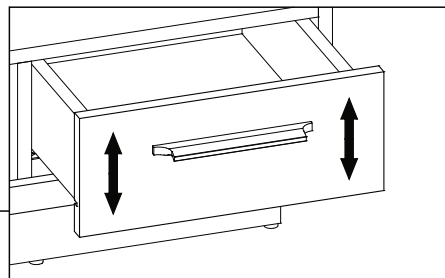
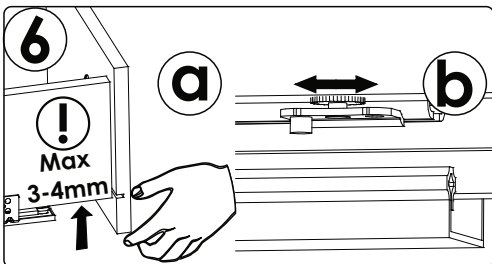
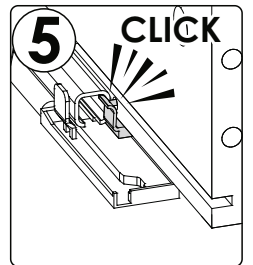
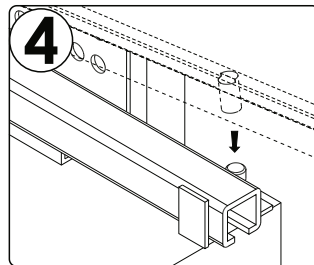
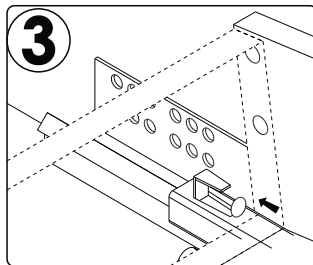
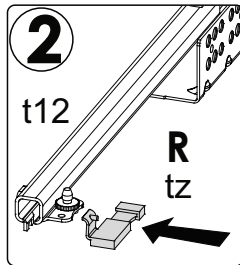
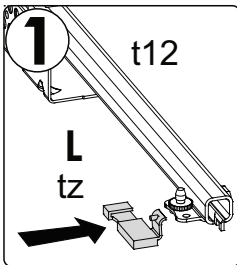
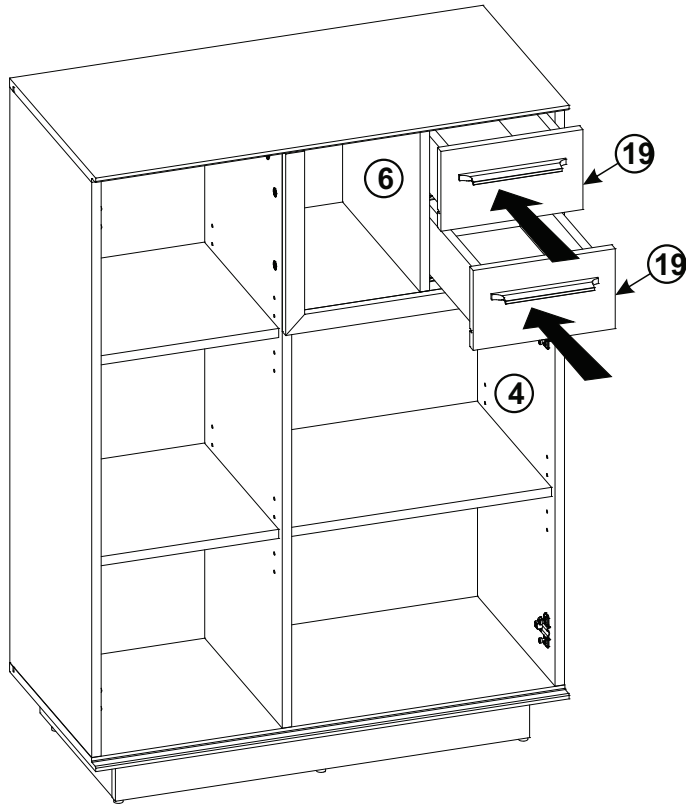
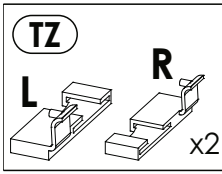

41

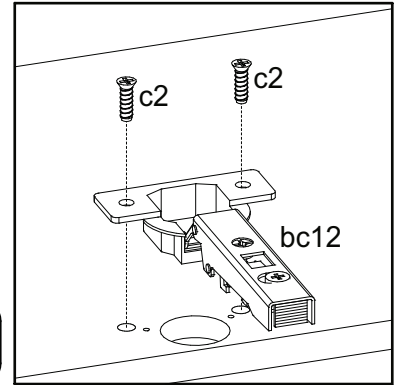
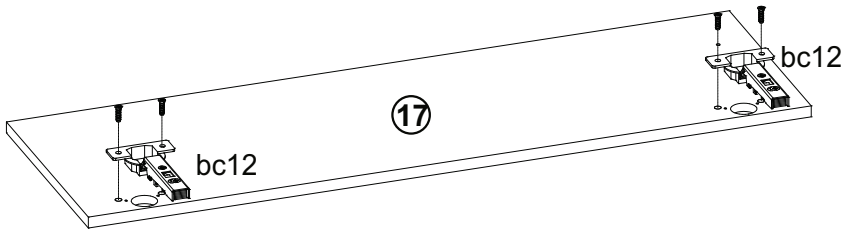
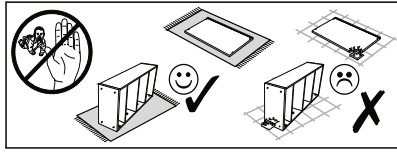
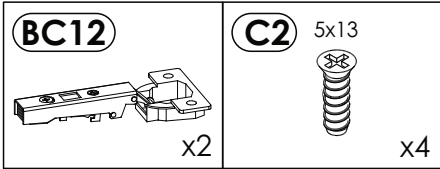

42

