

**Gebrauchsanleitung / Instructions / Mode d'emploi /
Gebruiksaanwijzing / Instrucciones**

PAIDI
Möbel GmbH
Hauptstraße 87
D-97840 Hafeloehr/Main

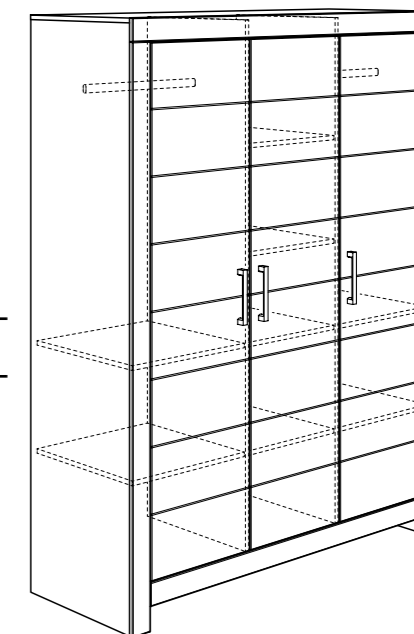

131 0111
131 0112

1:1
DIN A3

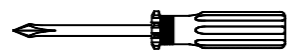
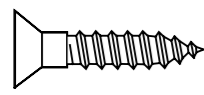
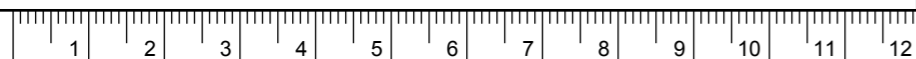

ca. 1,5h

A 18x 681 0759	B 8x 681 0757	C ø8 x 35 4x 681 0702	D 4x 681 1645	E 3,5 x 13 4x 681 4887	F 4x 681 2794	G 8x 681 2796	H 6,3 x 50 2x 681 5311	SW4 1x 681 3011
I 4x 681 2497	J 6,3 x 15 4x 681 5060	K 12x 681 2498	L 32x 681 0350	Y 20x 683 0101	Z 4x 681 2552			

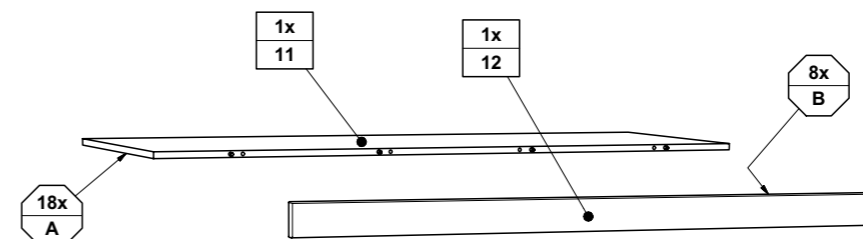

131 0111

M CHROM-Matt 3x 671 7387	O M4 x 22 6x 681 3807
--	---------------------------------------

131 0112

N CHROM-Glanz 3x 671 7288	O M4 x 22 6x 681 3807
---	---------------------------------------

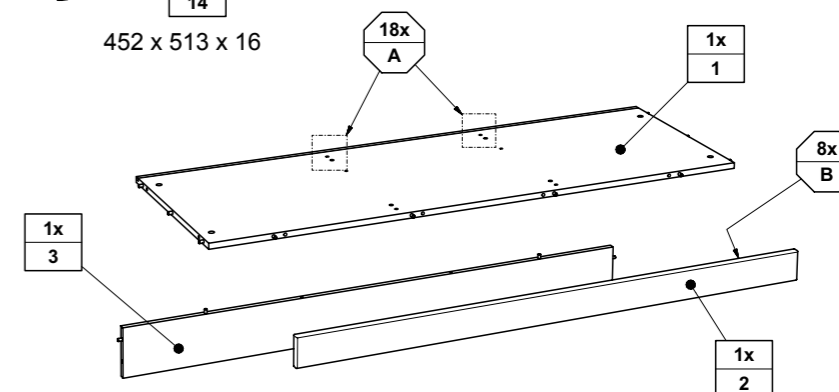
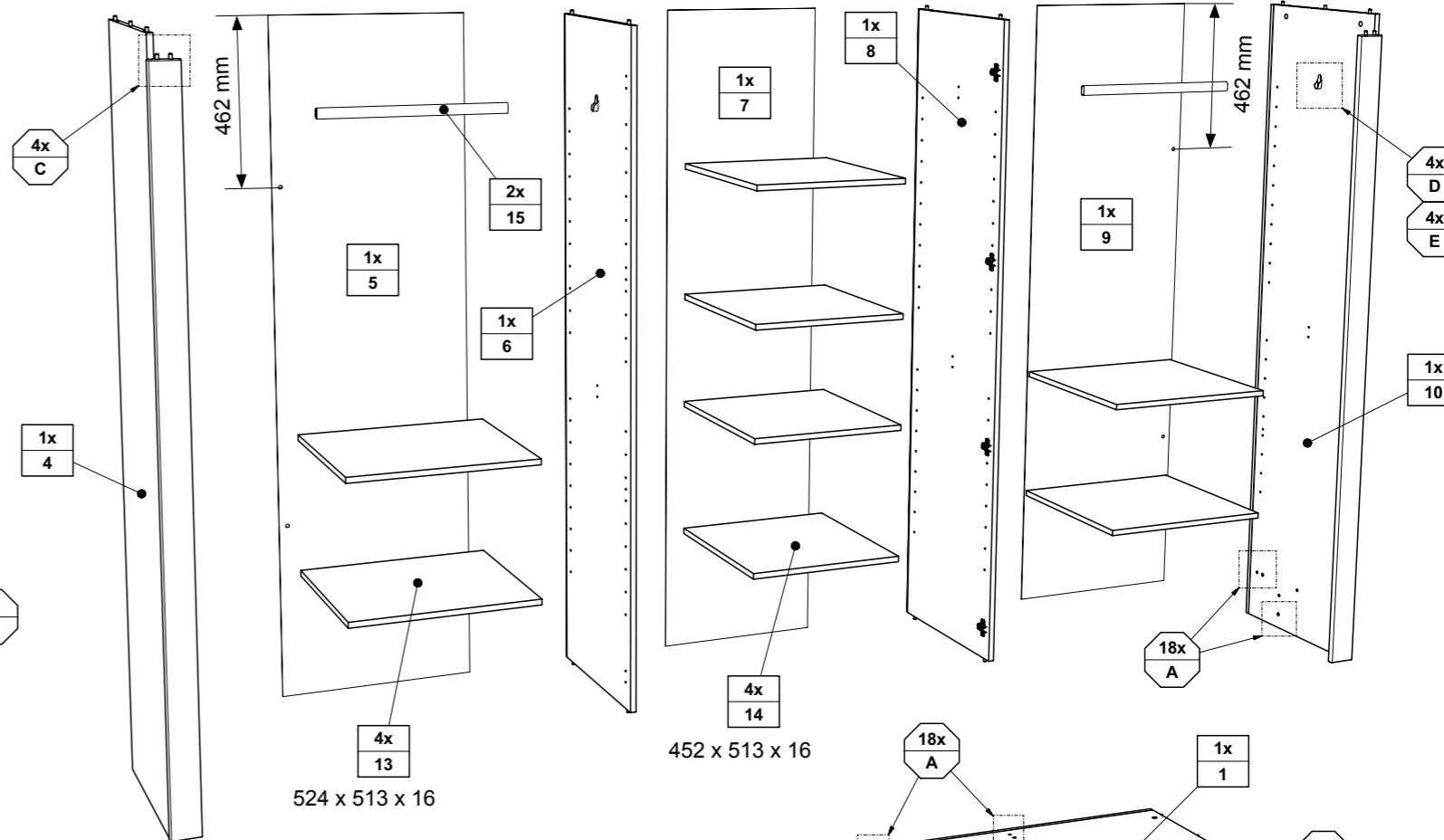
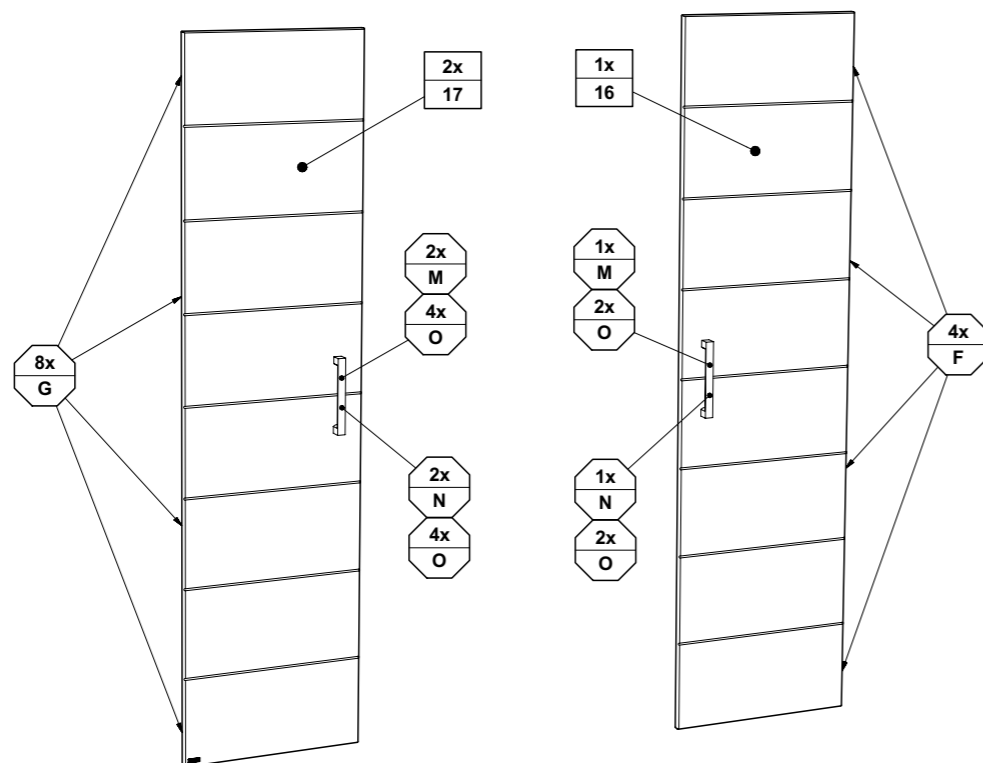

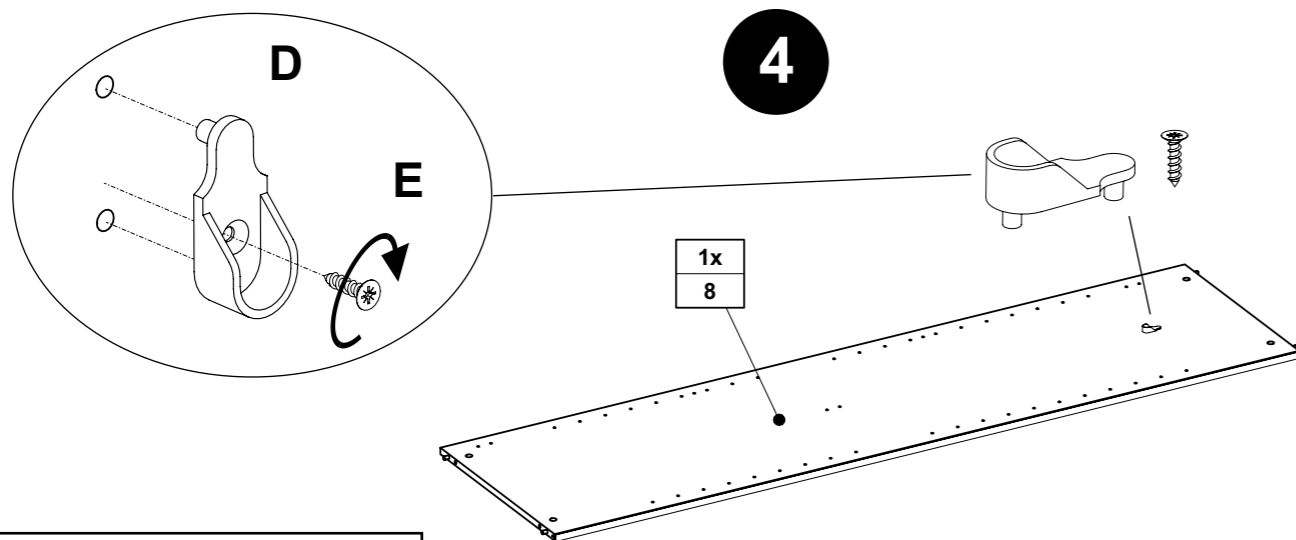
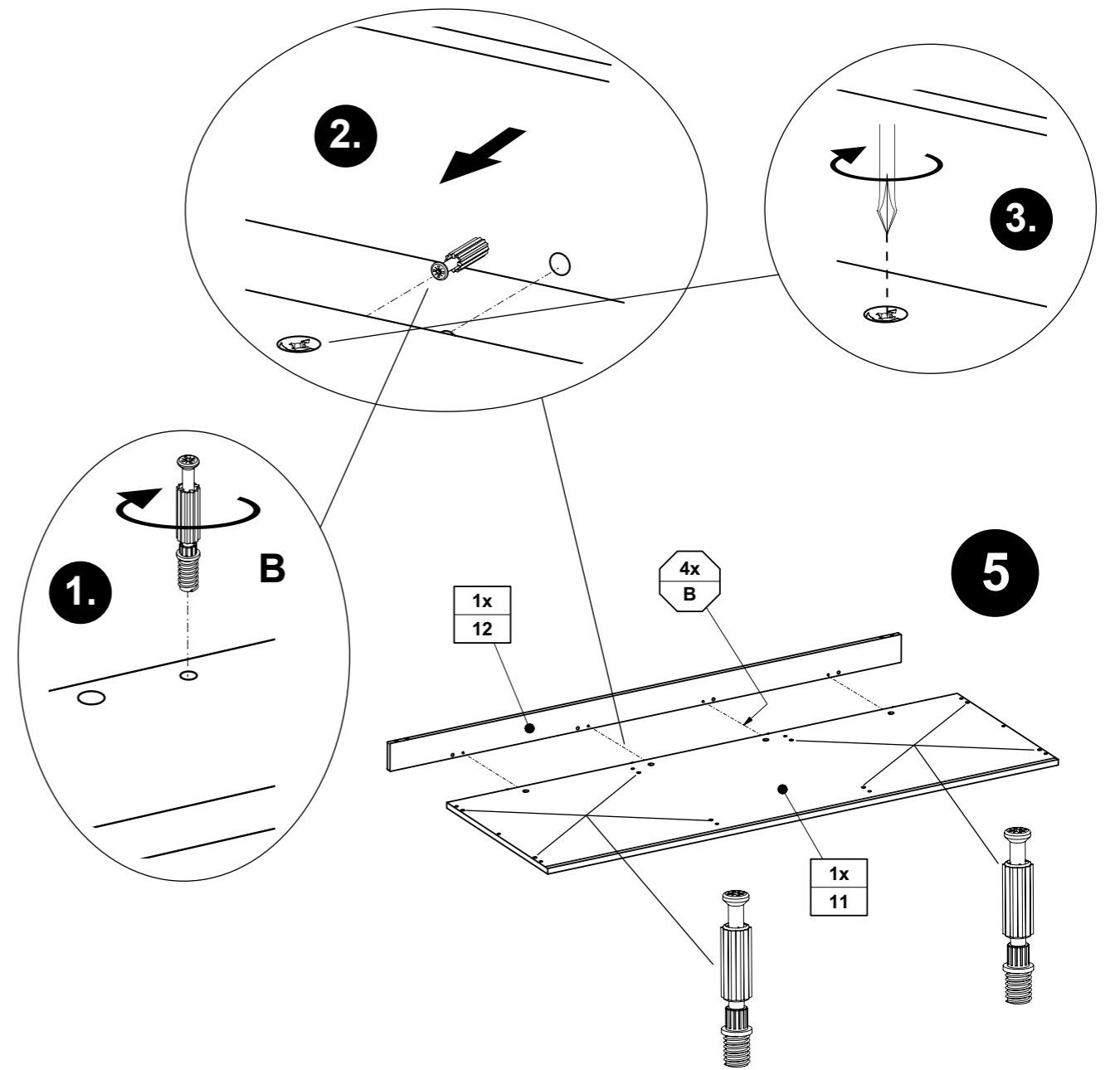
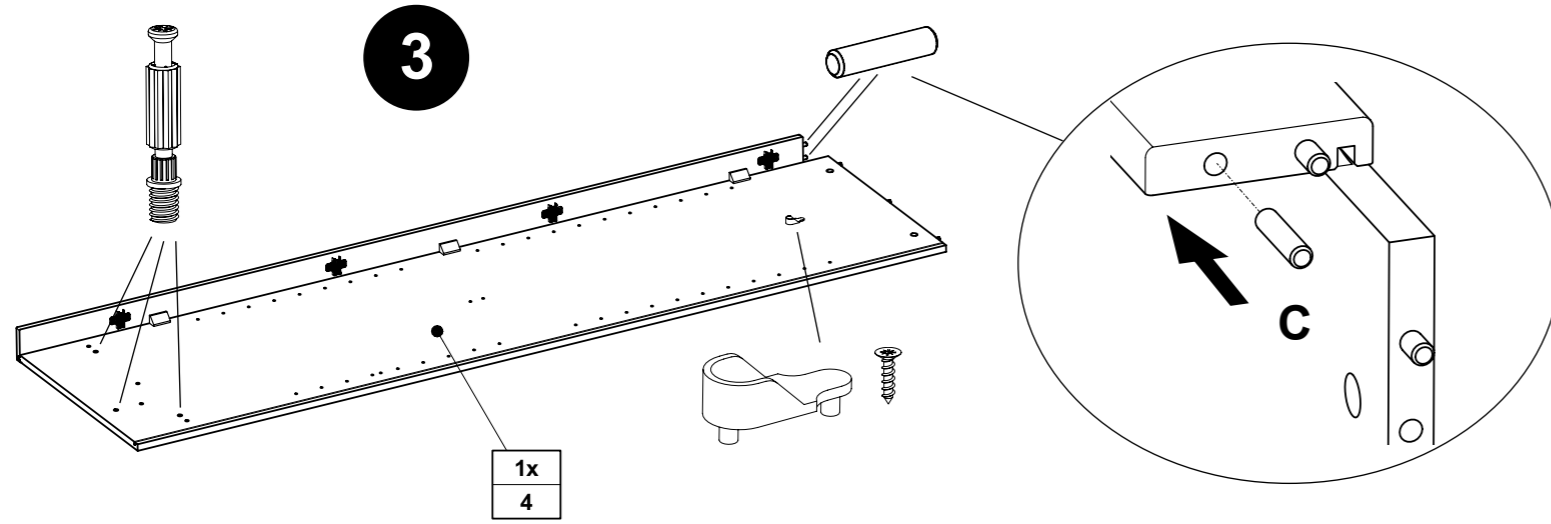
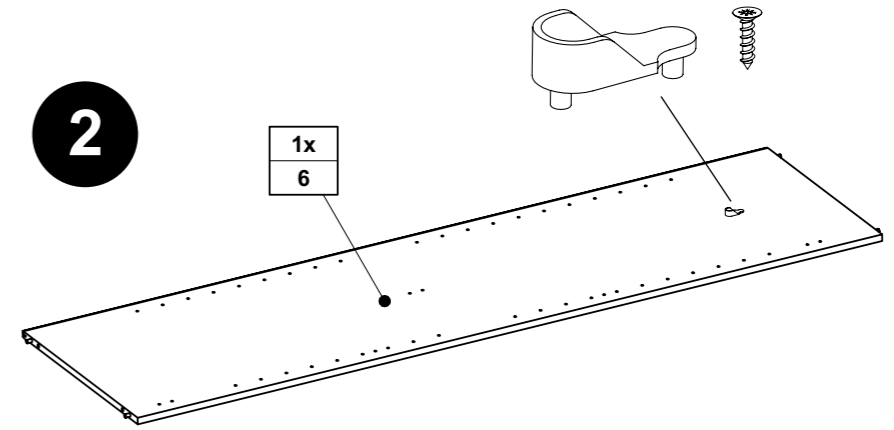
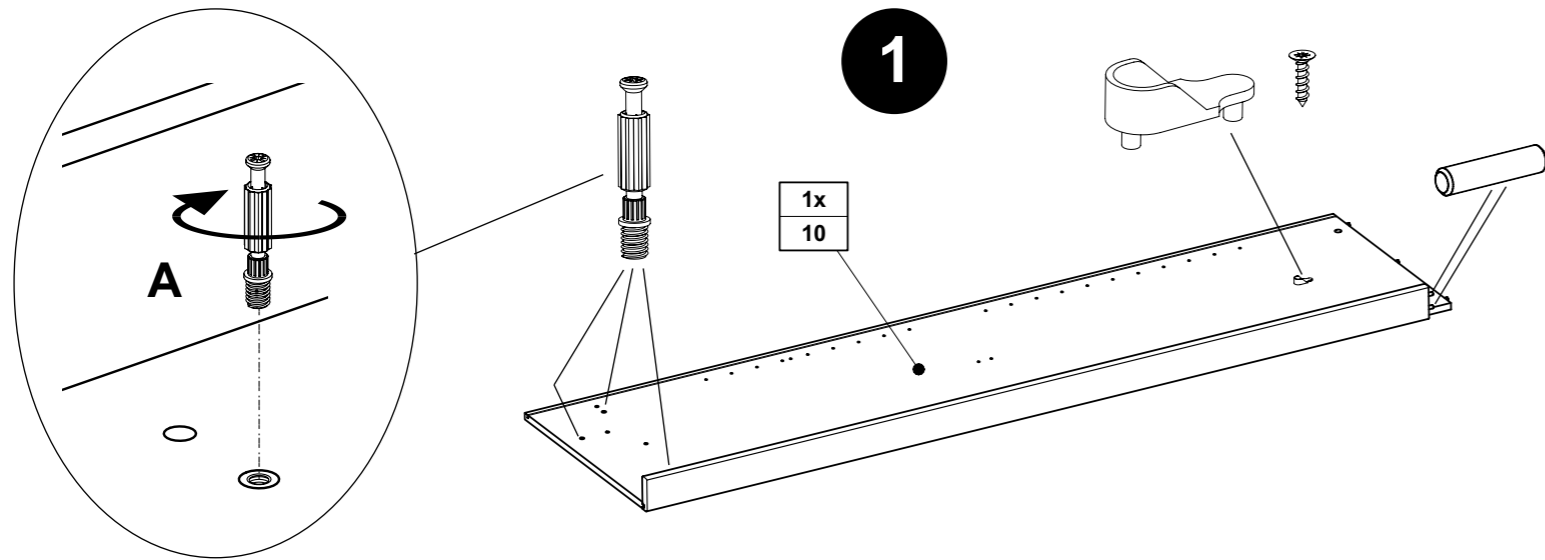

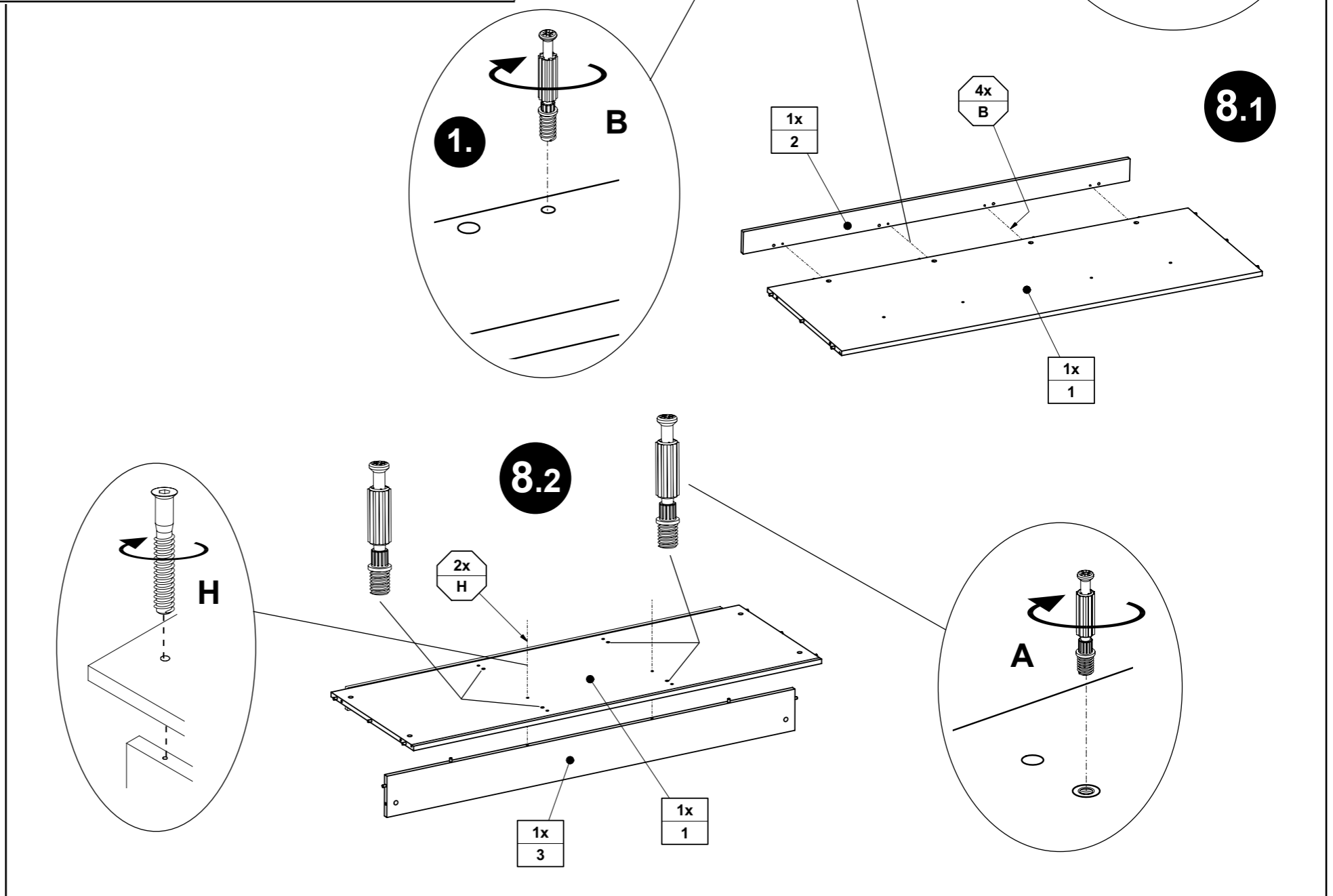
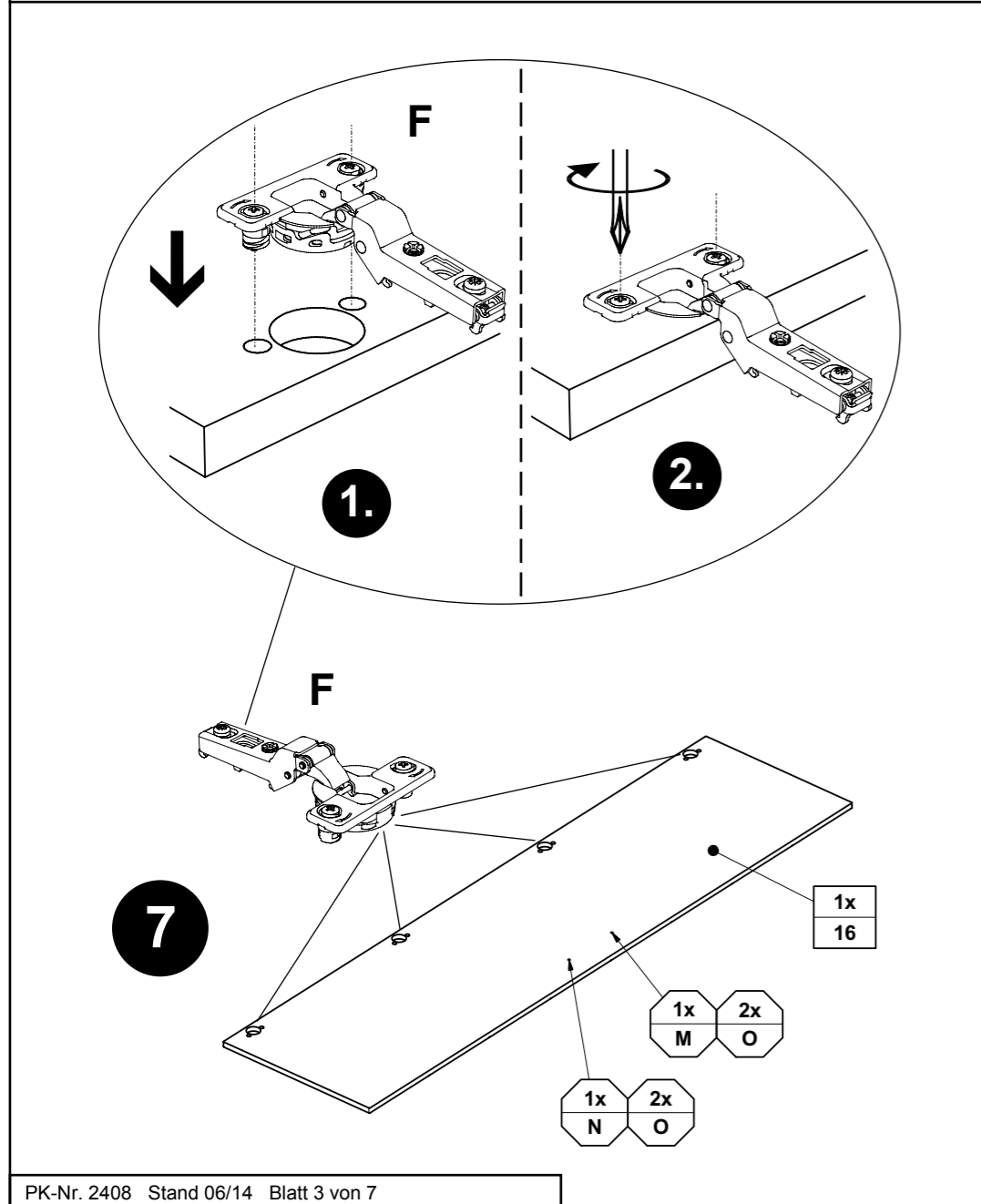
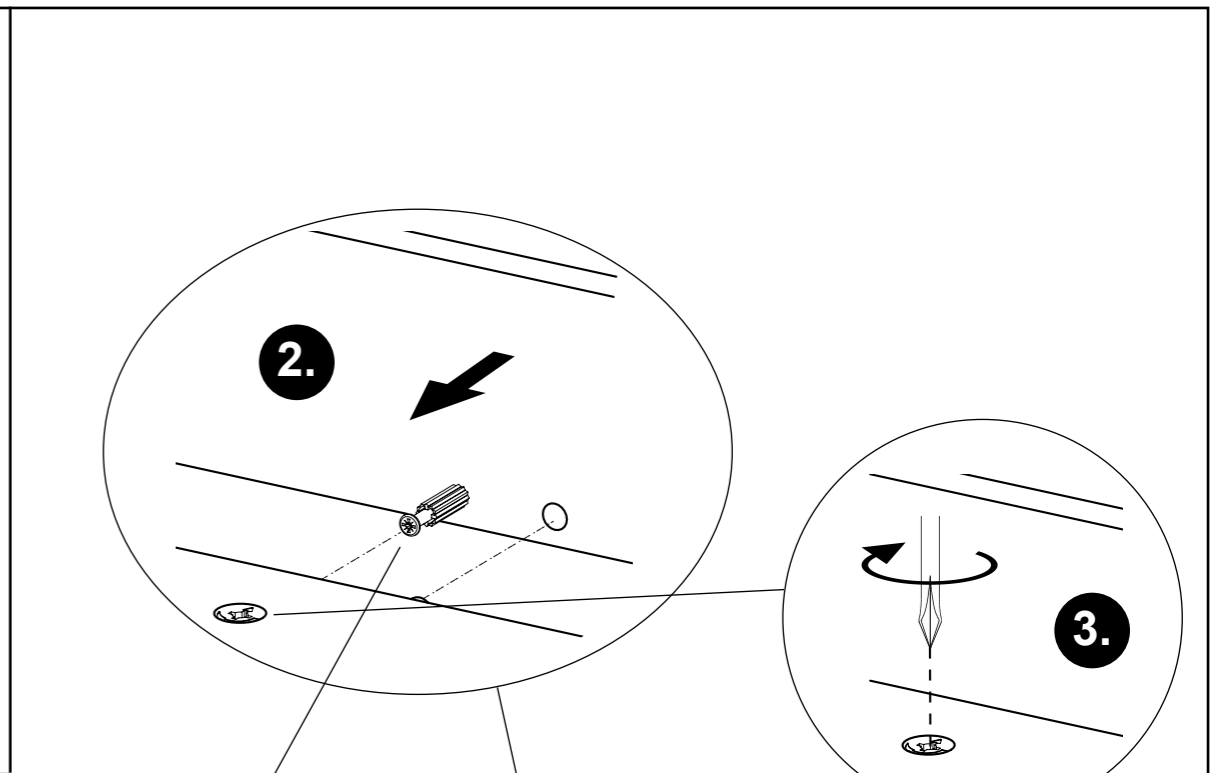
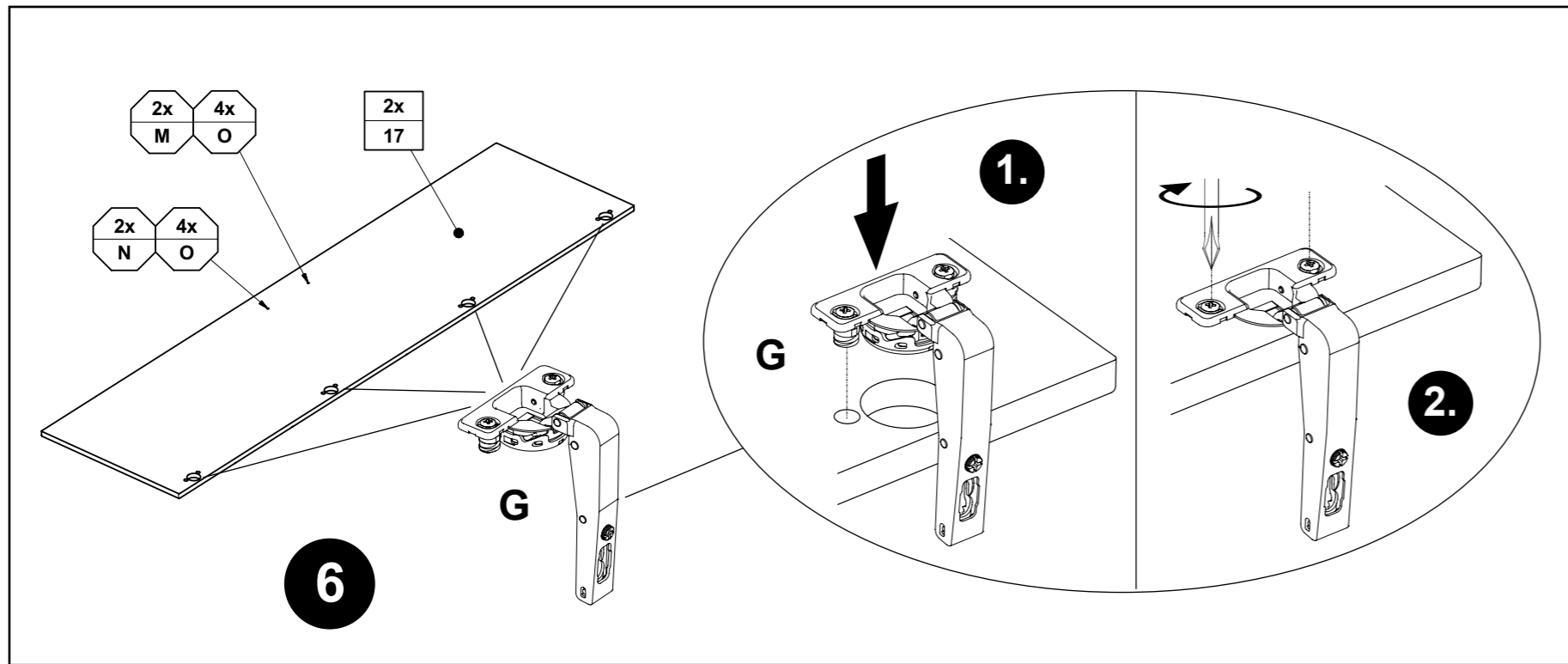

9

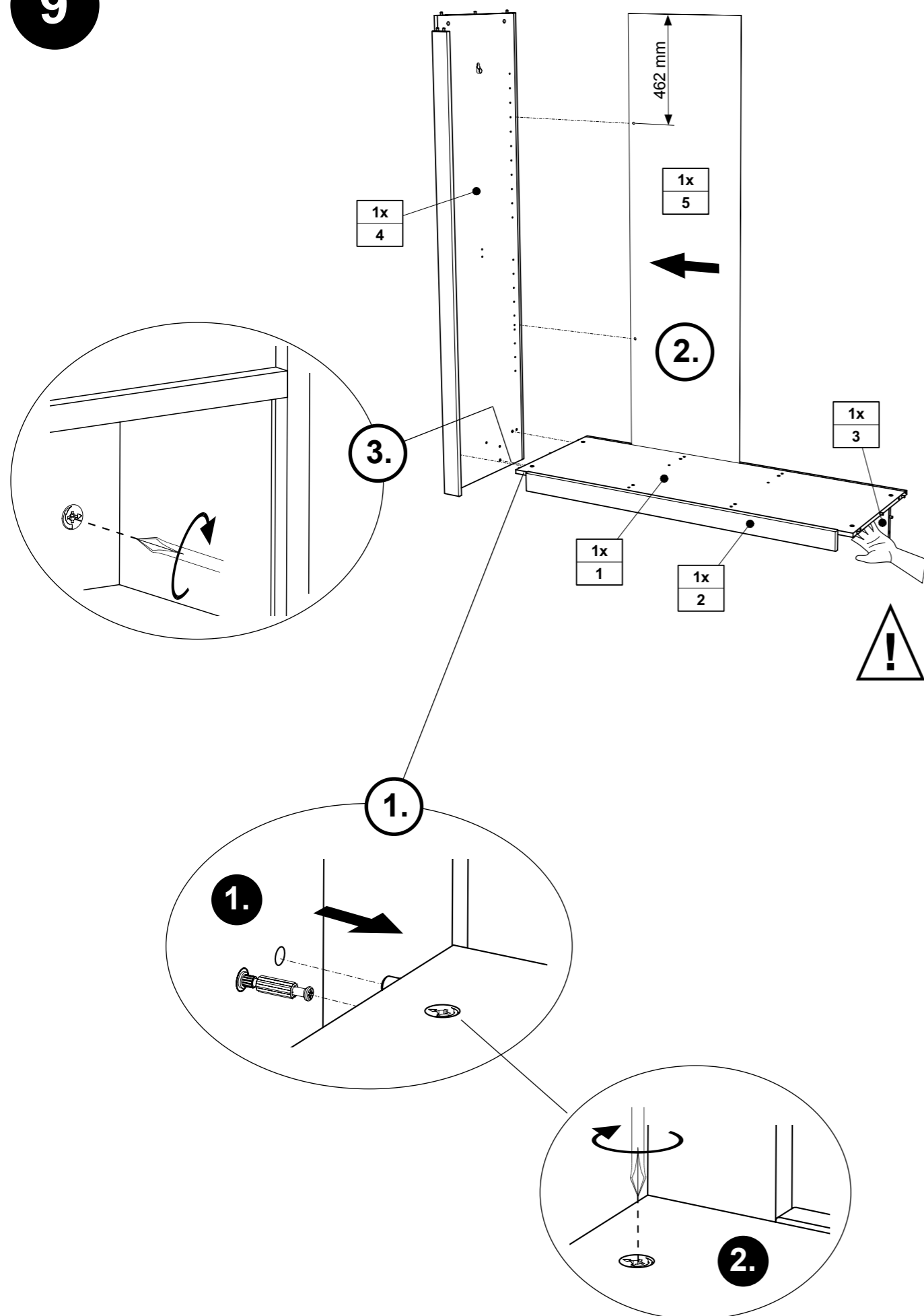

10

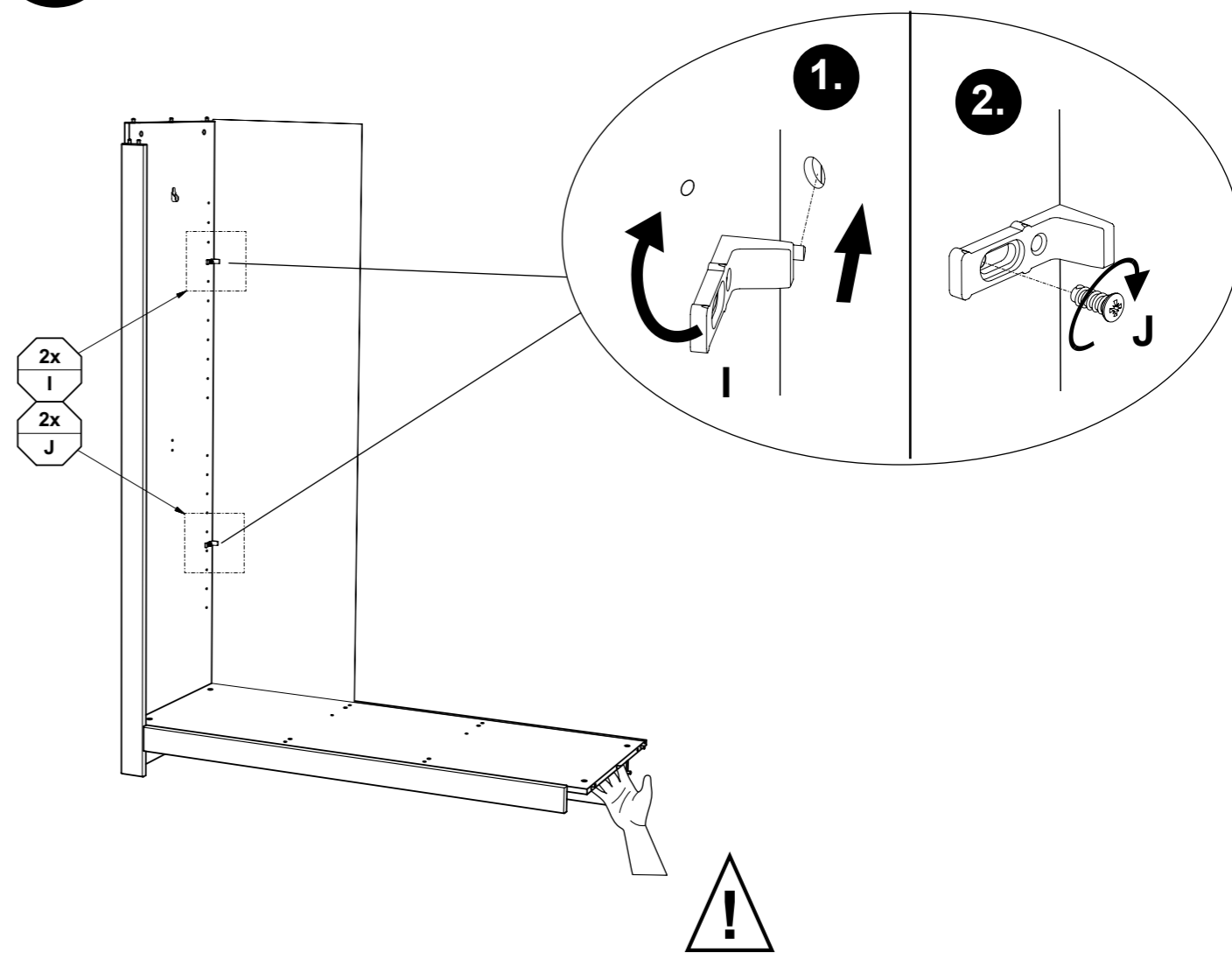

- DE **Pflegehinweis:** Zum Reinigen der Oberflächen ein leicht-feuchtes Tuch oder ein handelsübliches Möbelpflegemittel verwenden.
- FR **Indication sur l'entretien :** pour nettoyer les surfaces, utiliser un chiffon légèrement humide ou un nettoyant pour meubles en vente dans le commerce
- GB **Caring for the...** : In order to clean the surfaces please use a slightly damp cloth or commercially available furniture care product.
- NL **Verzorgingsanwijzing:** Voor het reinigen van de oppervlakken een licht vochtig doek of een gebruikelijk meubelschoonmaakmiddel gebruiken.
- ES **Recomendaciones de cuidado:** Para limpiar las superficies del mueble debe usar un trapo humedecido o un producto de limpieza de muebles comercial.
- GR **Οδηγίες περιποίησης:** Για το καθάρισμα των επιφανειών να χρησιμοποιείτε ένα ελαφρά νοτισμένο πανάκι ή λούστρο επίπλων.
- IT **Indicazione per pulizia e cura:** Per la pulizia delle superfici utilizzate un panno leggermente umido o un normale prodotto per la cura dei mobili.
- CZ **Pokyny k čištění:** Na čištění povrchu použijte pouze navlhčený kousek látky nebo běžný prostředek na ošetrování nábytku.
- SK **Pokyn k ošetrovaniu:** Na čistenie povrchu používajte mierne navlhčenú handru alebo bežný čistiaci prostriedok na nábytok.
- SI **Navodilo za nego:** Za čiščenje površin uporabljajte malo vlažno cunjjo ali trgovsko običajno sredstvo za nego pohištva.
- DK **Pleje:** Rens overflader med en fugtig klud eller et gængs møbelplejemedel.
- SE **Skötselråd:** Rengör ytorna med en fuktig trasa eller med ett vanligt möbelrengöringsmedel som finns i handeln.
- FI **Hoito-ohje:** Käytä pintojen puhdistukseen kosteata pyyhettä tai yleisen kauppalaadun mukaista huonekalujen hoito-ainetta.
- PL **Wskazówka pielęgnacyjna:** do czyszczenia powierzchni stosować lekko wilgotną ściereczkę lub zwykły środek do pielęgnacji mebli.
- HU **Ápolási útmutató:** A felületek tisztításához egy enyhén nedves kendőt, vagy kereskedelemben kapható, szokványos bútorpótló szert használjon.
- RO **Indicații de întreținere:** pentru curățirea suprafețelor folosiți o cârpă umezită ușor sau un produs comercial obișnuit pentru îngrijirea mobilei.
- BG **Указание за поддържане:** Използвайте леко навлажнена кърпа или обикновен препарат за поддържане на мебели, за да почистите повърхностите.
- HR **Upute za njegu:** Za čišćenje površina upotrijebiti jednu lako navlaženu krpu i trgovačko uobičajeno sredstvo za njegu namještaja.
- LT **Rekomendacija priežiūrai:** Paviršius valykite drėgna pašluoste arba parduotuvėse įsigytais baldų priežiūros priemonėmis.
- RU **Рекомендации по уходу:** для очистки поверхностей используйте слегка влажную тряпку или обычное средство по уходу за мебелью.
- CN **保养说明:** 清洁表面只需用稍微潮湿的布或普通的家具清洁剂即可。

11

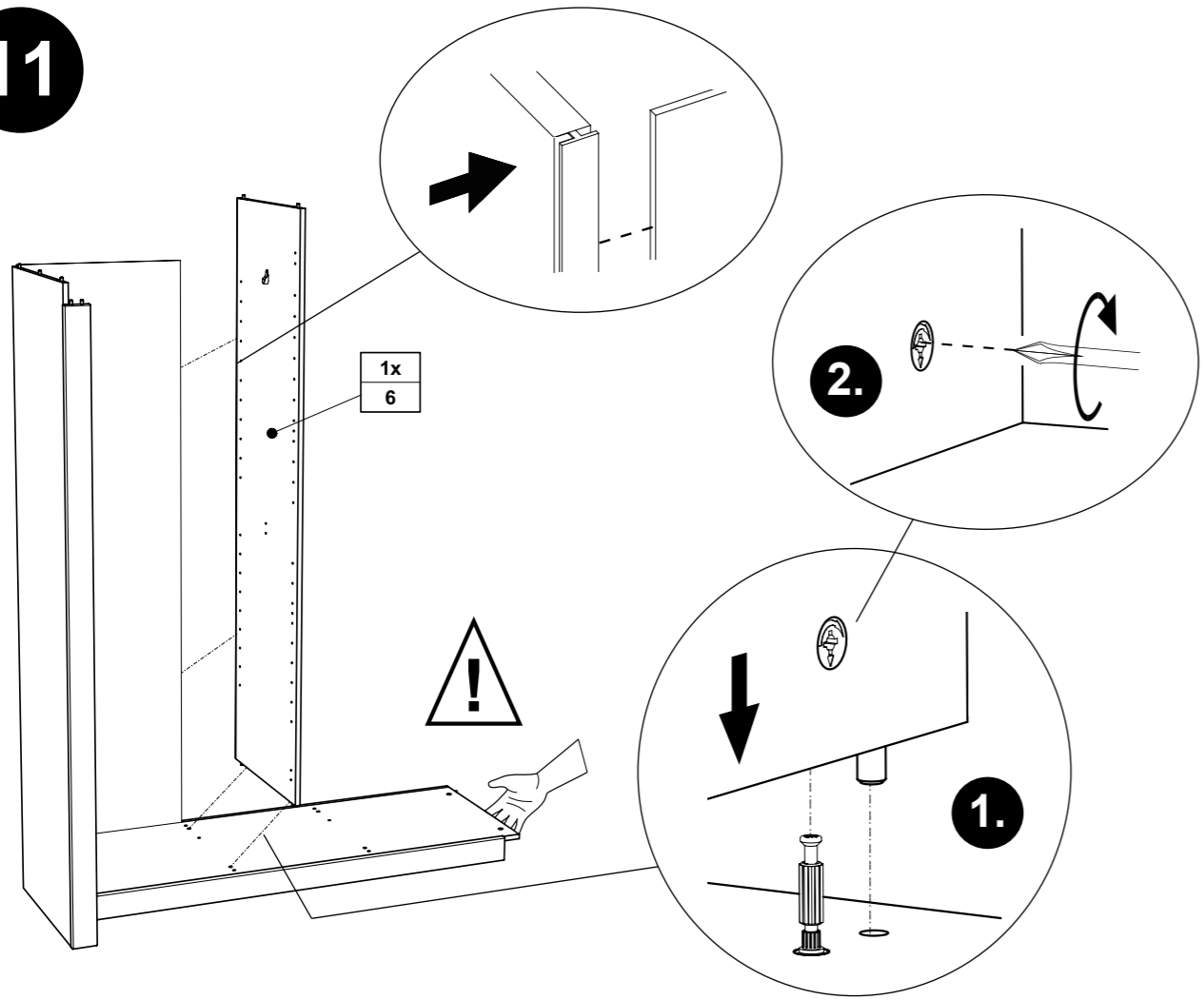

12

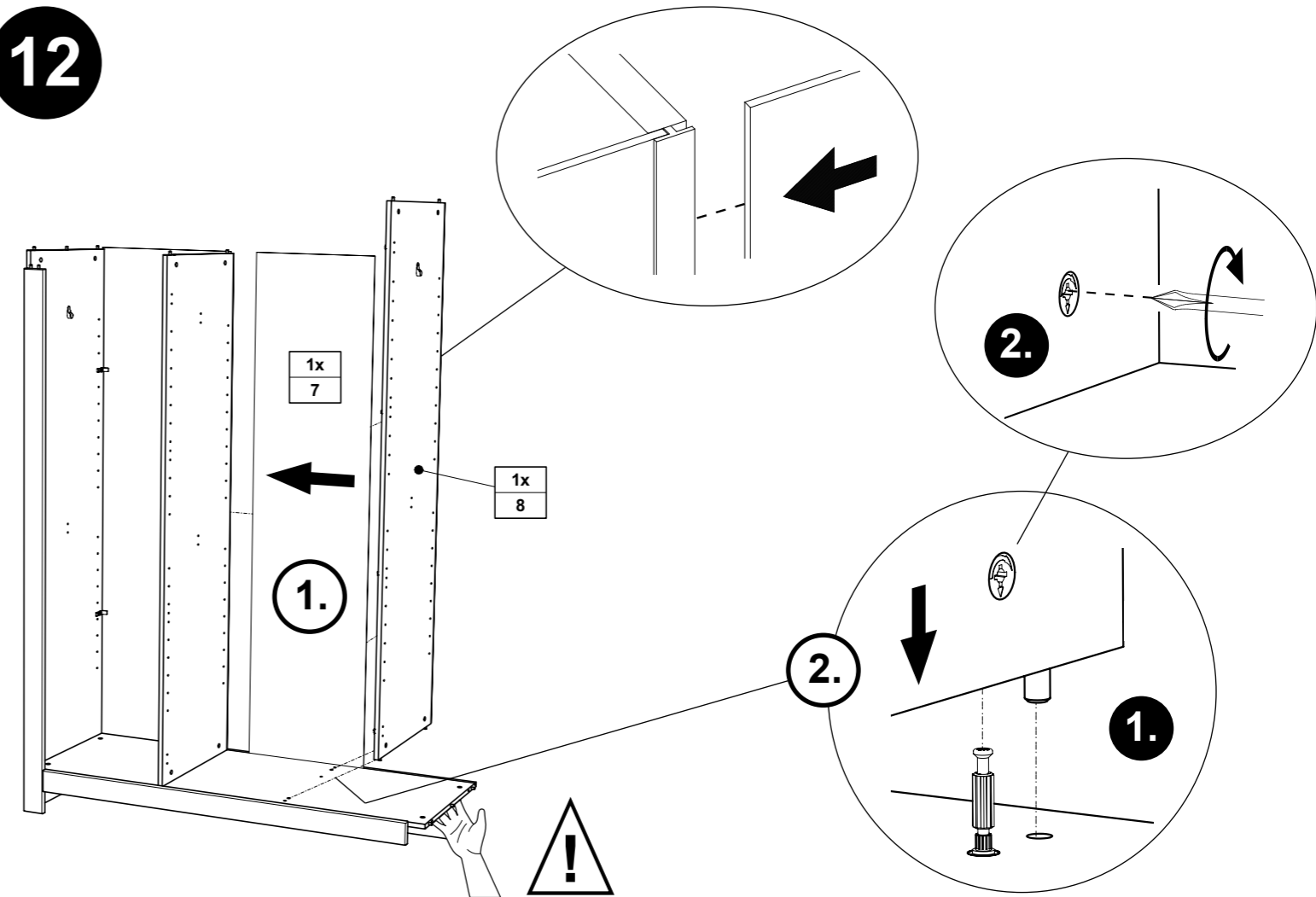

13

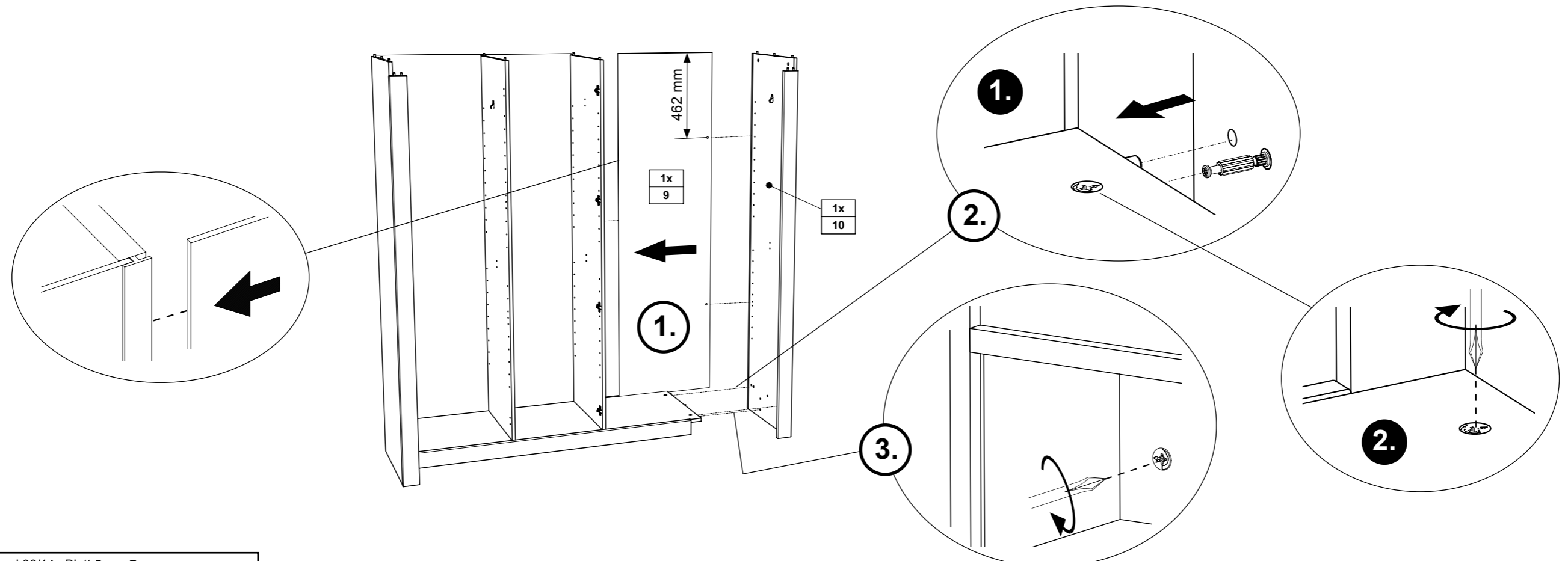

14

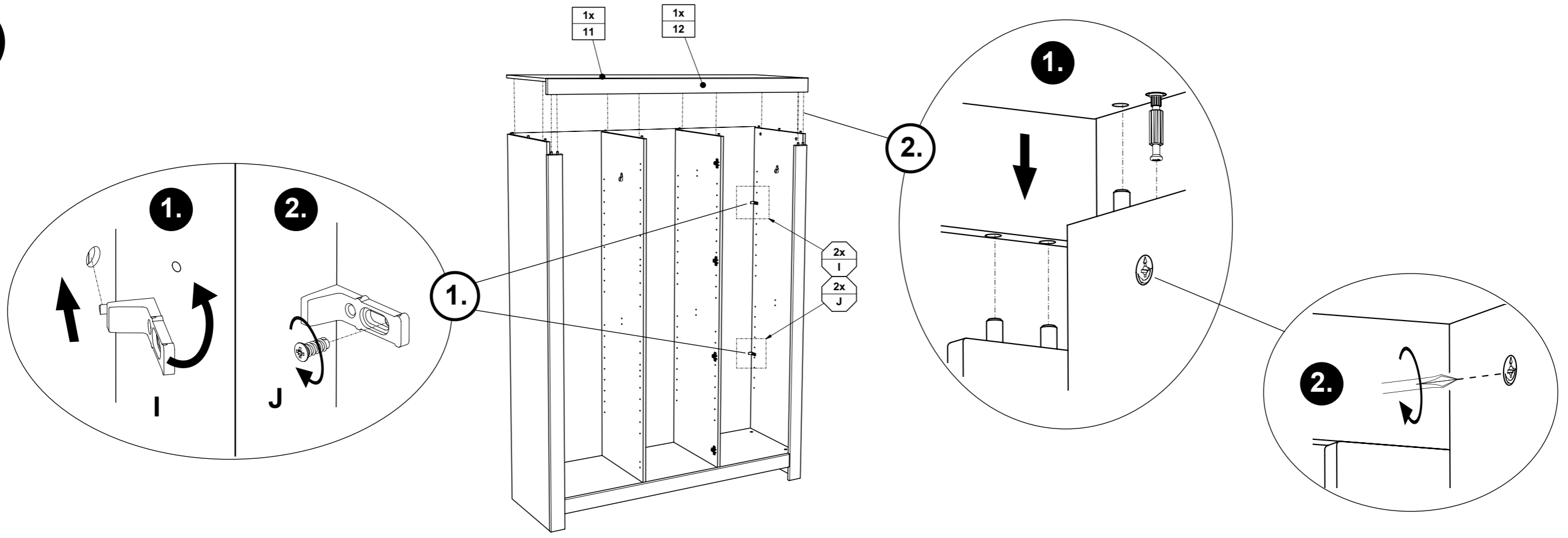

15

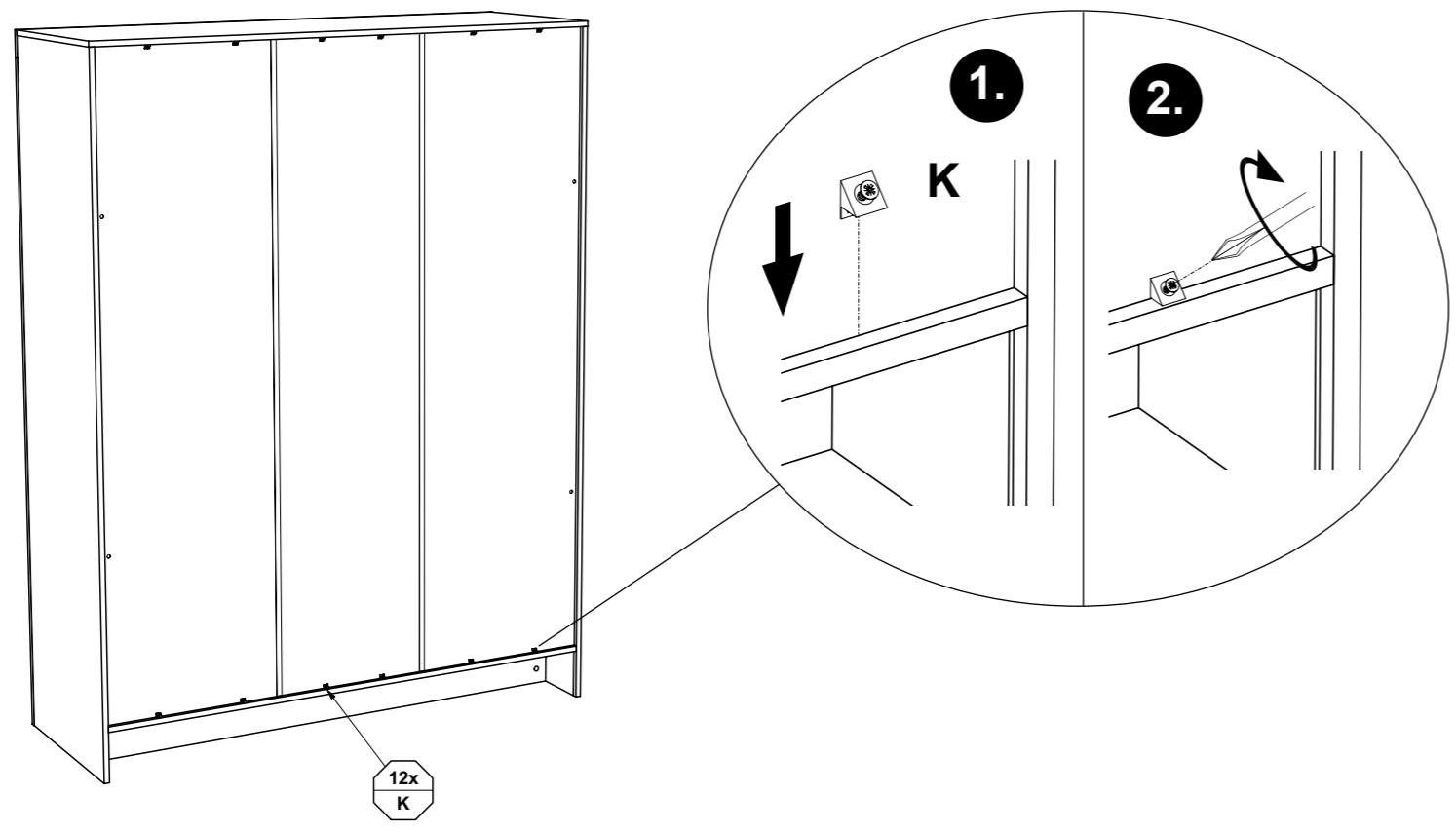

16

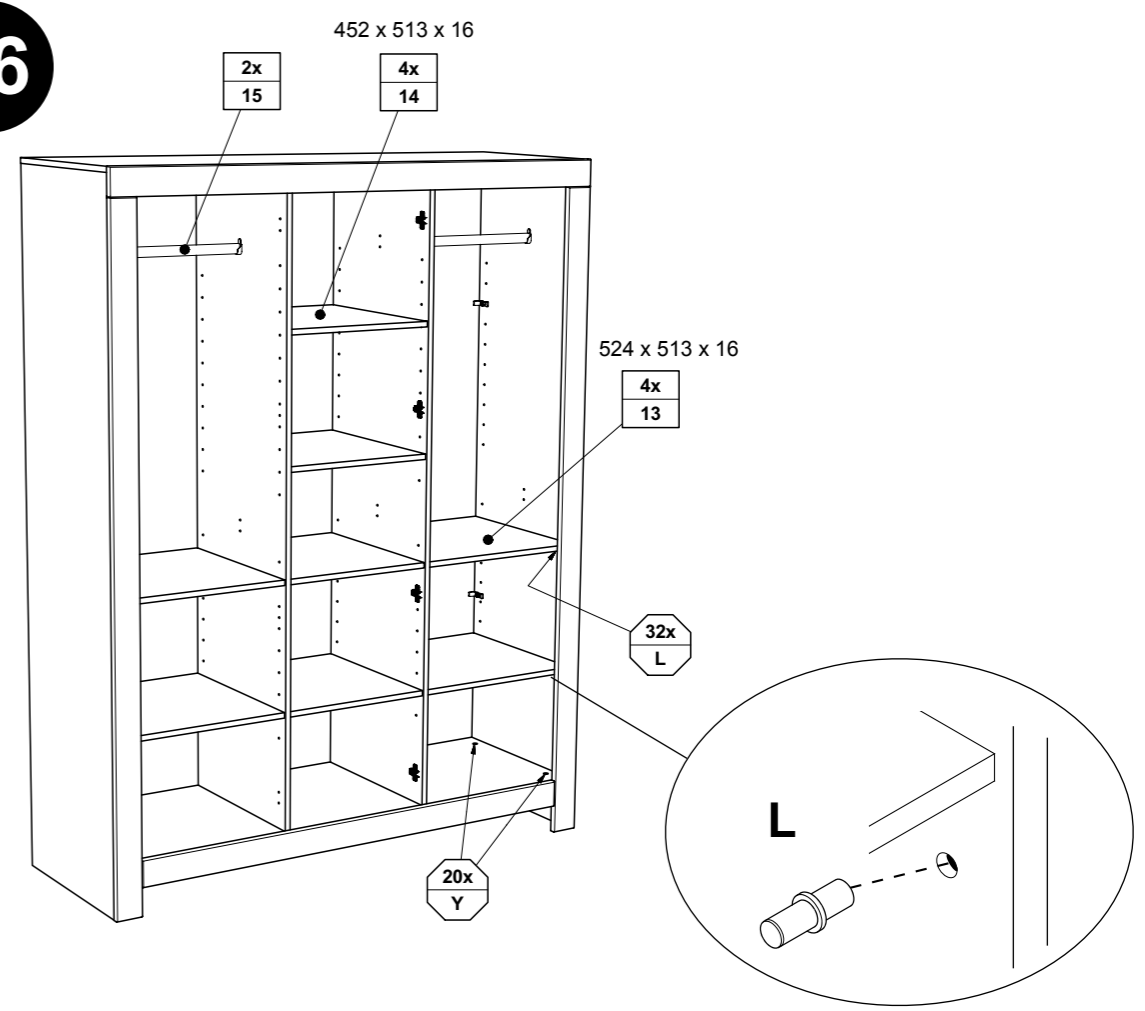

17

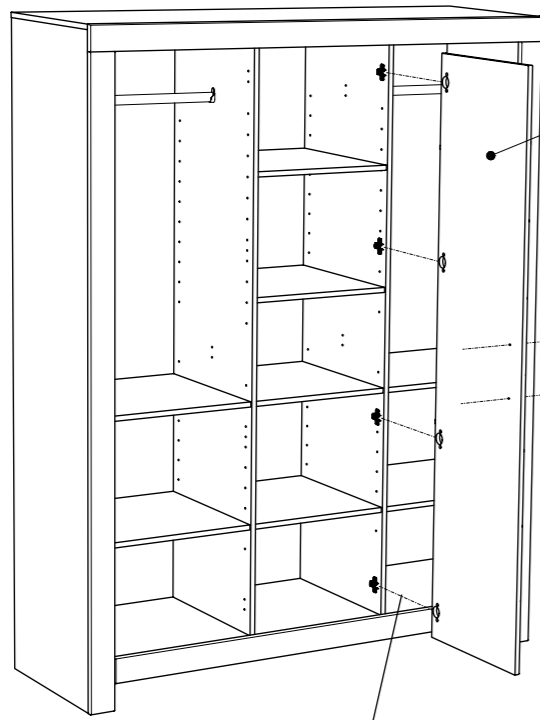

Demontage der Türen
dismounting the doors
Démontage des portes
dismontaje van de deuren
Desmontaje de las puertas

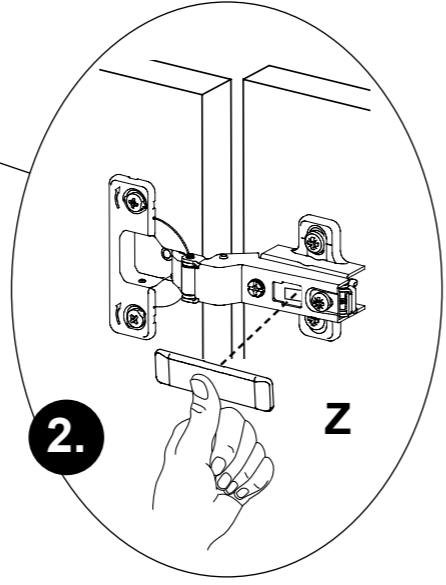
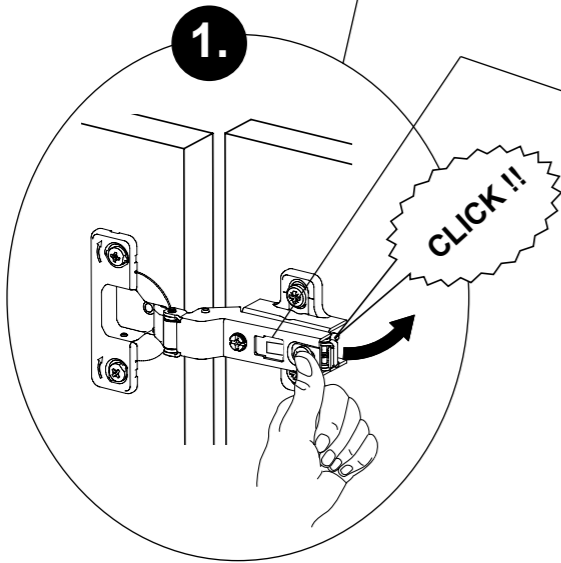
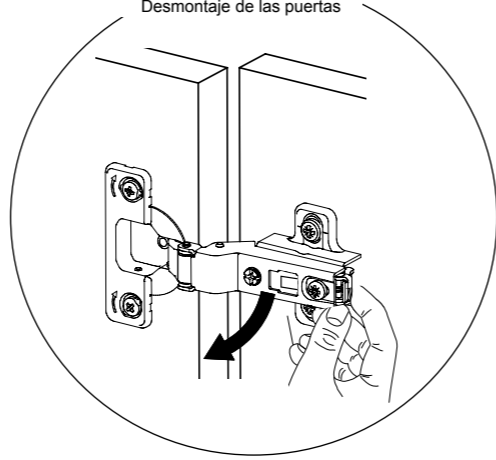

18

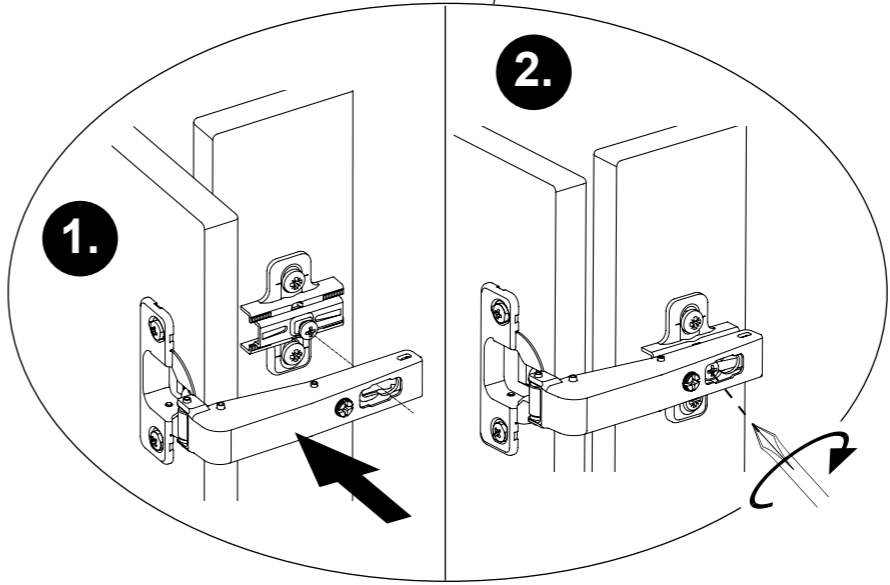
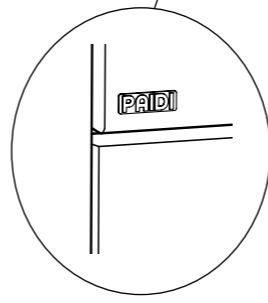
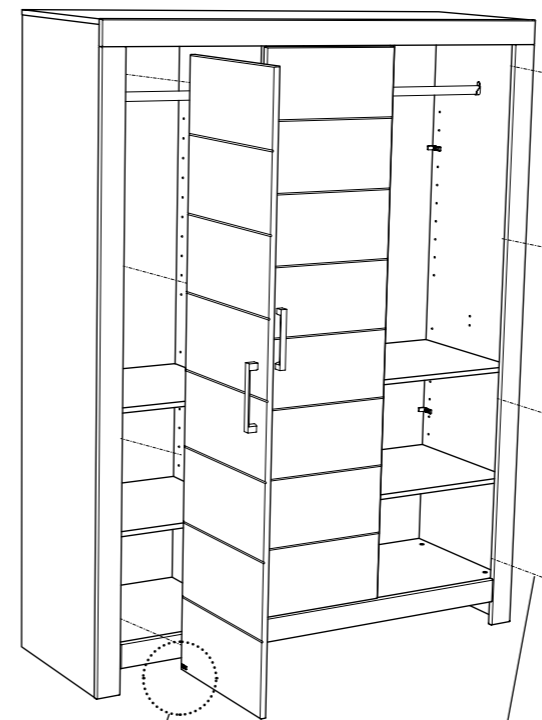

Justierung der Türen
Adjustement of doors
Ajustement des portes
Uitlijnen van de deuren
Ajuste de las puertas

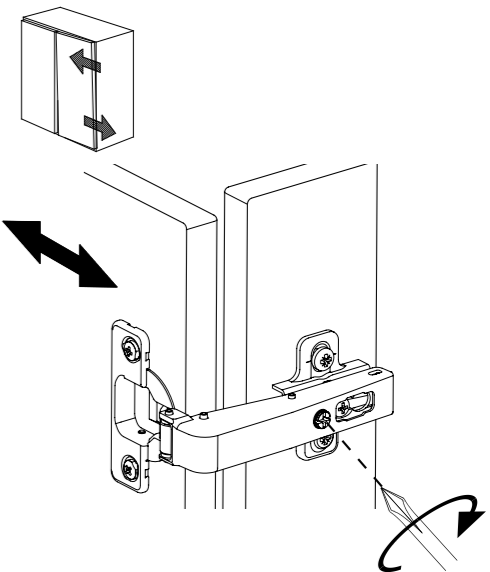
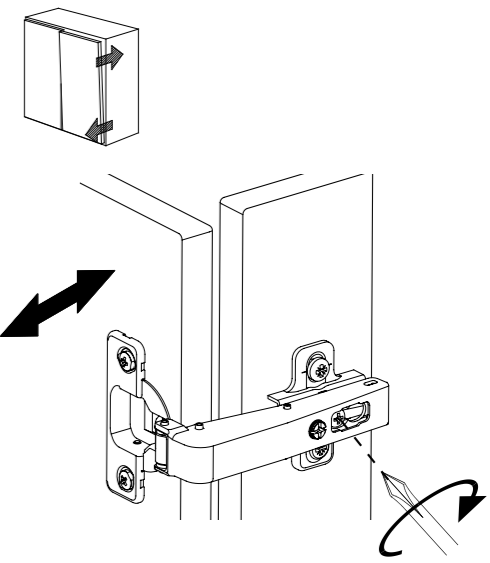
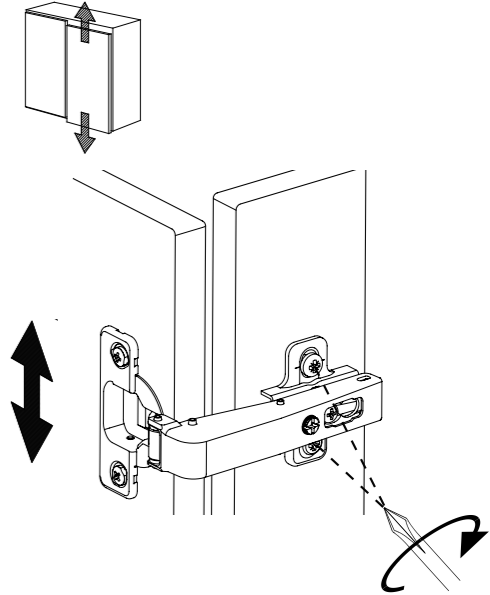

Justierung der Türen
Adjustement of doors
Ajustement des portes
Uitlijnen van de deuren
Ajuste de las puertas

