

# Gebrauchsanleitung / Instructions / Mode d'emploi / Gebruiksaanwijzing / Instrucciones

PAIDI  
Möbel GmbH  
Hauptstraße 87  
D-97840 Hafenhofr/Main

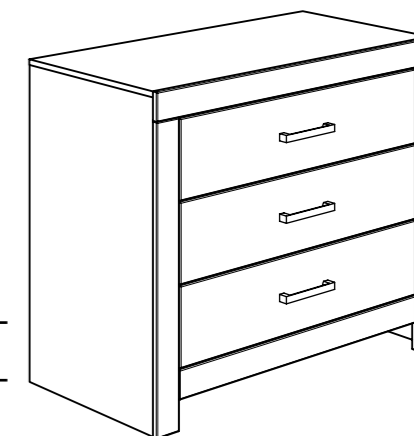

1:1  
DIN A3

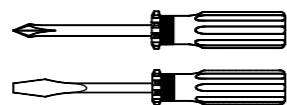
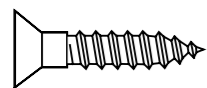
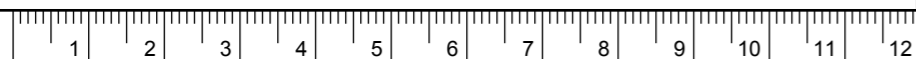

ca. 0,75h



**131 5501**  
**131 5502**

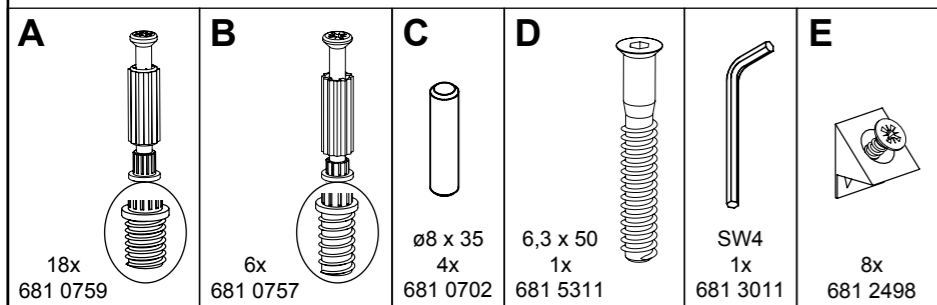

**131 5501**

**131 5502**

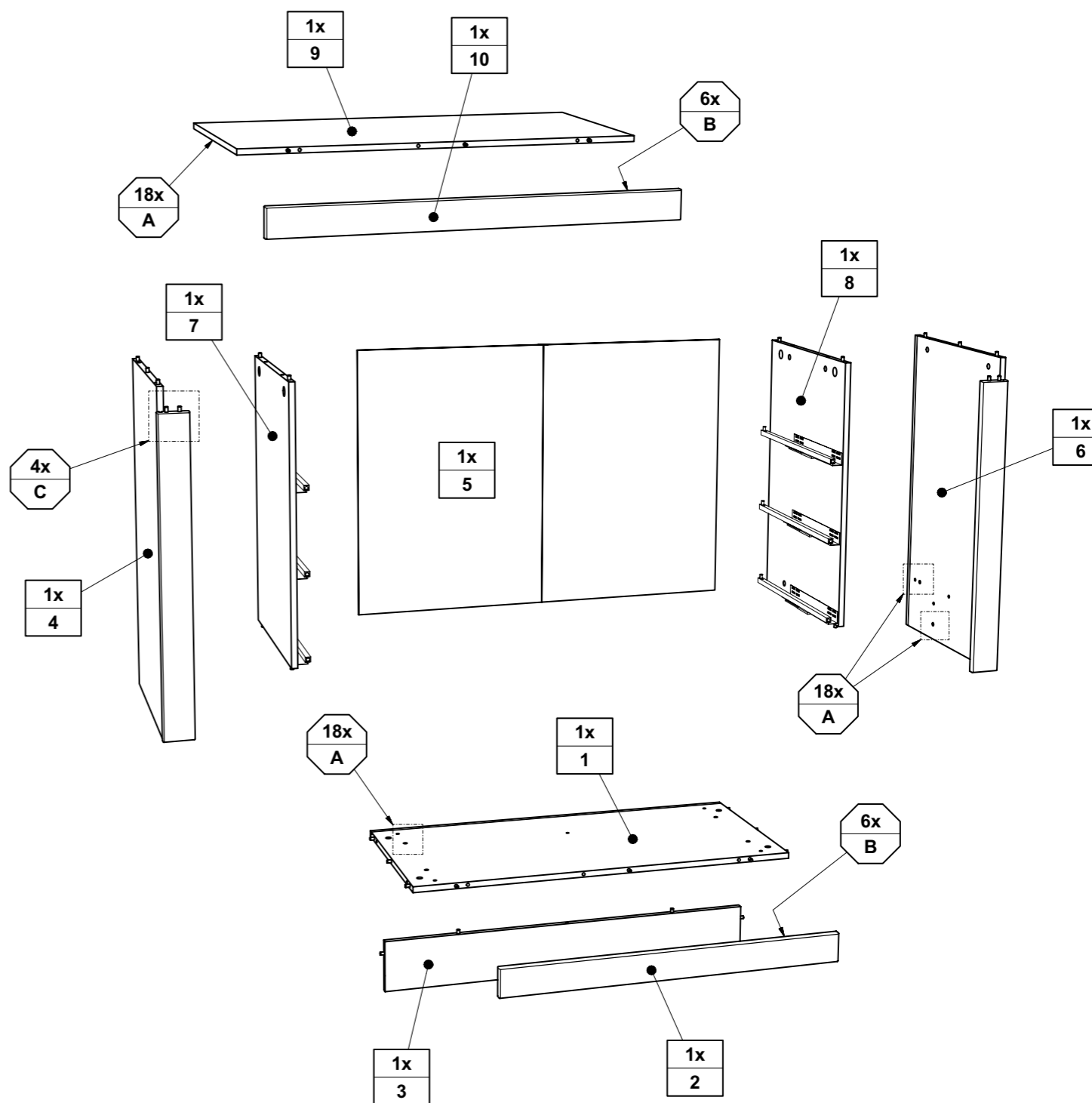
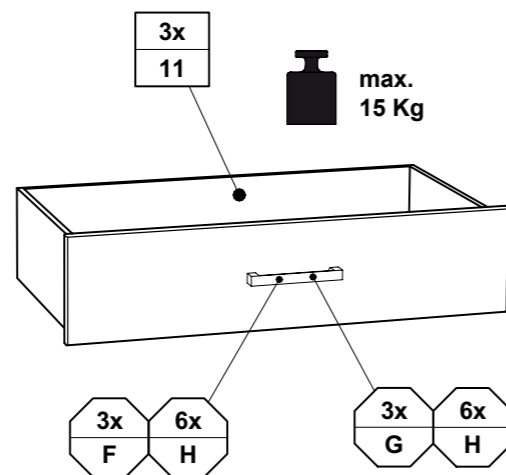
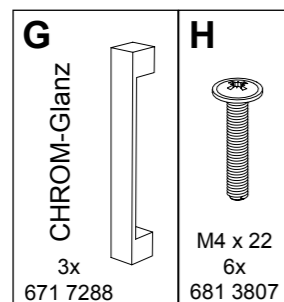
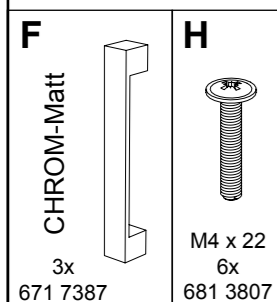

**DE Pflegehinweis:** Zum Reinigen der Oberflächen ein leicht-feuchtes Tuch oder ein handelsübliches Möbelpflegemittel verwenden.  
**FR Indication sur l'entretien :** pour nettoyer les surfaces, utiliser un chiffon légèrement humide ou un nettoyeur pour meubles en vente dans le commerce  
**GB Caring for the...** : In order to clean the surfaces please use a slightly damp cloth or commercially available furniture care product.  
**NL Verzorgingsaanwijzing:** Voor het reinigen van de oppervlakken een licht vochtig doek of een gebruikelijk meubelschoonmaakmiddel gebruiken.  
**ES Recomendaciones de cuidado:** Para limpiar las superficies del mueble debe usar un trapo humedecido o un producto de limpieza de muebles comercial.  
**GR Οδηγίες περιποίησης:** Για το καθάρισμα των επιφανειών να χρησιμοποιείτε ένα ελαφρά νοτισμένο πανάκι ή λούστρο επίπλων.  
**IT Indicazione per pulizia e cura:** Per la pulizia delle superfici utilizzate un panno leggermente umido o un normale prodotto per la cura dei mobili.  
**CZ Pokyny k čištění:** Na čištění povrchu použijte pouze navlhčený kousek látky nebo běžný prostředek na ošetřování nábytku.  
**SK Pokyn k ošetrovaniu:** Na čistenie povrchu používajte mierne navlhčenú handru alebo bežný čistiaci prostriedok na nábytok.  
**SI Navodilo za nego:** Za čiščenje površin uporabljajte malo vlažno sunjo ali trgovsko običajno sredstvo za nego pohištva.  
**DK Pleje:** Rens overflader med en fugtig klud eller et gængs møbelplejemiddel.  
**SE Skötselråd:** Rengör ytorna med en fuktig trasa eller med ett vanligt möbelsvårningsmedel som finns i handeln.  
**FI Hoito-ohje:** Käytä pintojen puhdistukseen kosteata pyyhettä tai yleisen kauppalaadun mukaista huonekalujen hoito-ainetta.  
**PL Wskazówka pielęgnacyjna:** do czyszczenia powierzchni stosować lekko wilgotną ściereczkę lub zwykły środek do pielęgnacji mebli.  
**HU Ápolási útmutatás:** A felületek tisztításához egy enyhén nedves kendőt, vagy kereskedelemben kapható, szokványos bútoralpoló szert használjon.  
**RO Indicații de întreținere:** pentru curățirea suprafețelor folosiți o cârpă umezită ușor sau un produs comercial obișnuit pentru îngrijirea mobilei.  
**BG Указание за поддържане:** Използвайте леко навлажнена кърпа или обикновен препарат за поддържане на мебели, за да почистите повърхностите.  
**HR Upute za njegu:** Za čišćenje površina upotrijebiti jednu lako navlaženu krpu i trgovačko uobičajeno sredstvo za njegu namještaja.  
**LT Rekomendacija priežiūrai:** Paviršius valykite drėgna pašluoste arba parduotuvėse įsigytais baldų priežiūros priemonėmis.  
**RU Рекомендации по уходу:** для очистки поверхностей используйте слегка влажную тряпку или обычное средство по уходу за мебелью.  
**CN 保养说明:** 清洁表面只需用稍微潮湿的布或普通的家具清洁剂即可。

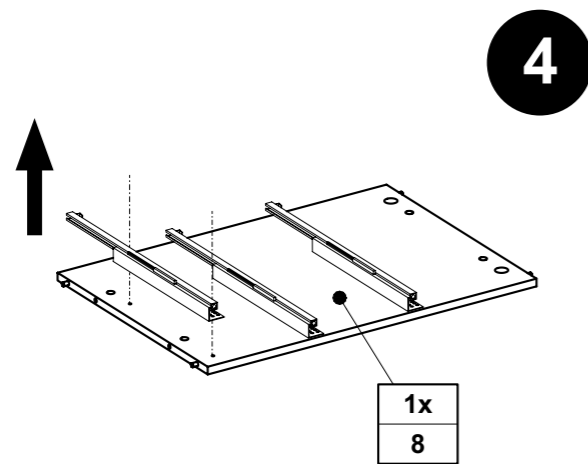
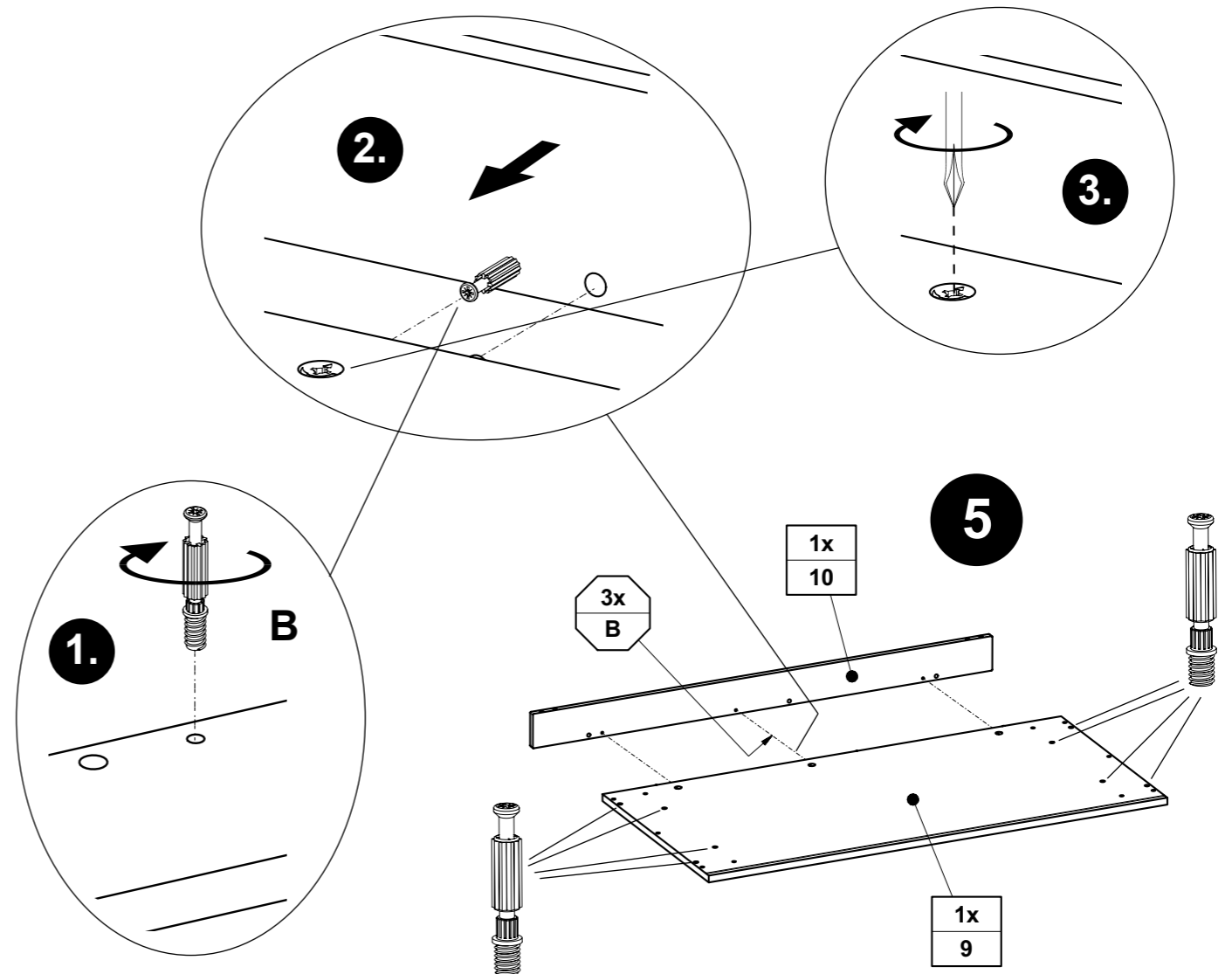
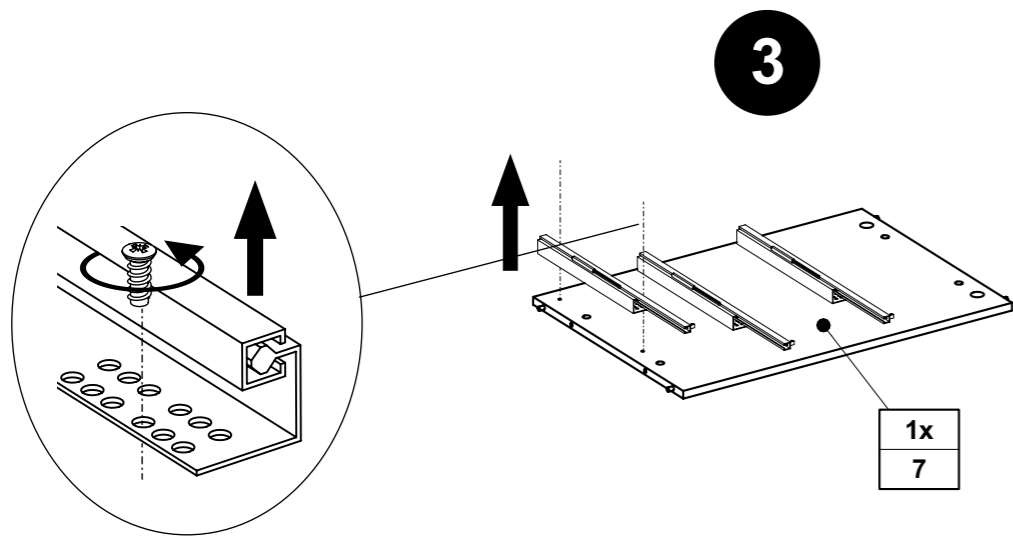
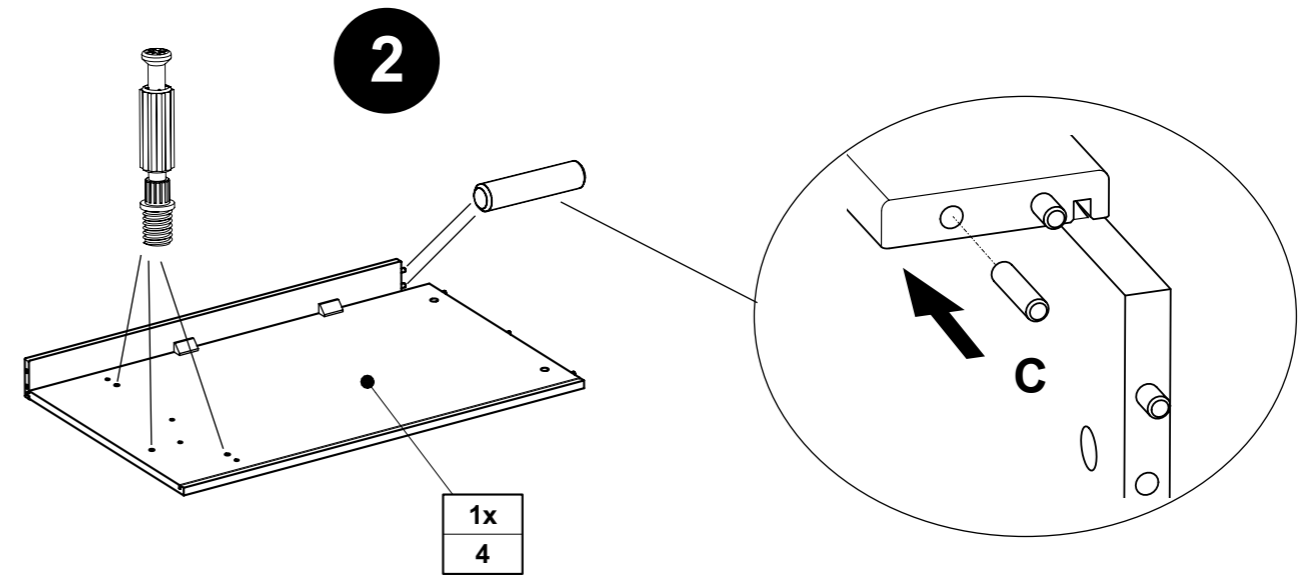
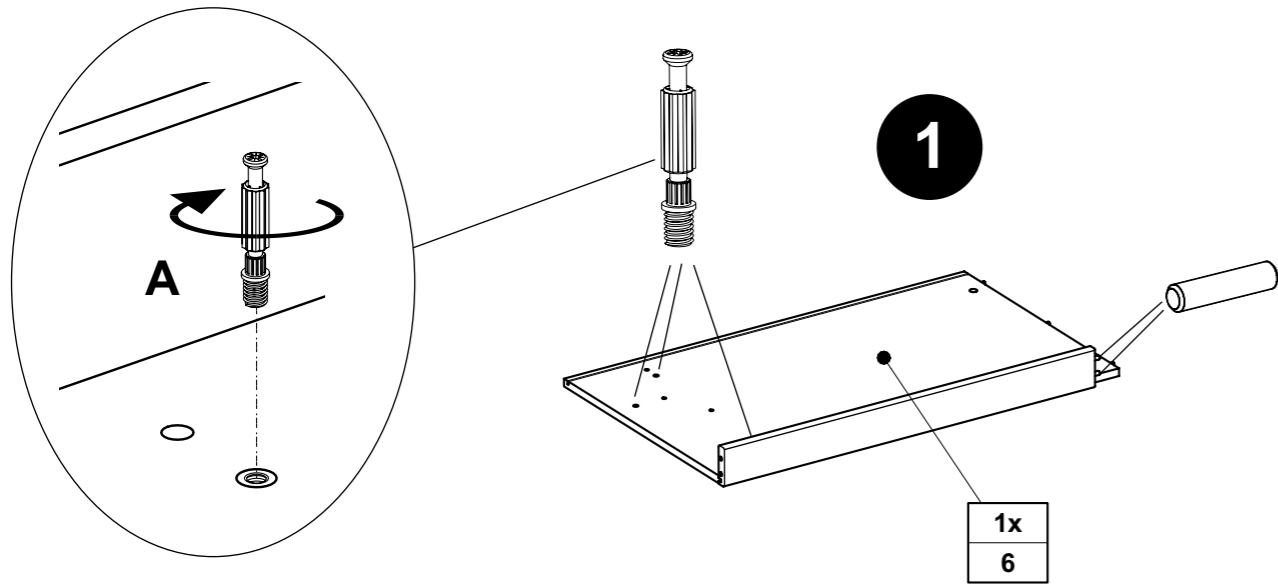

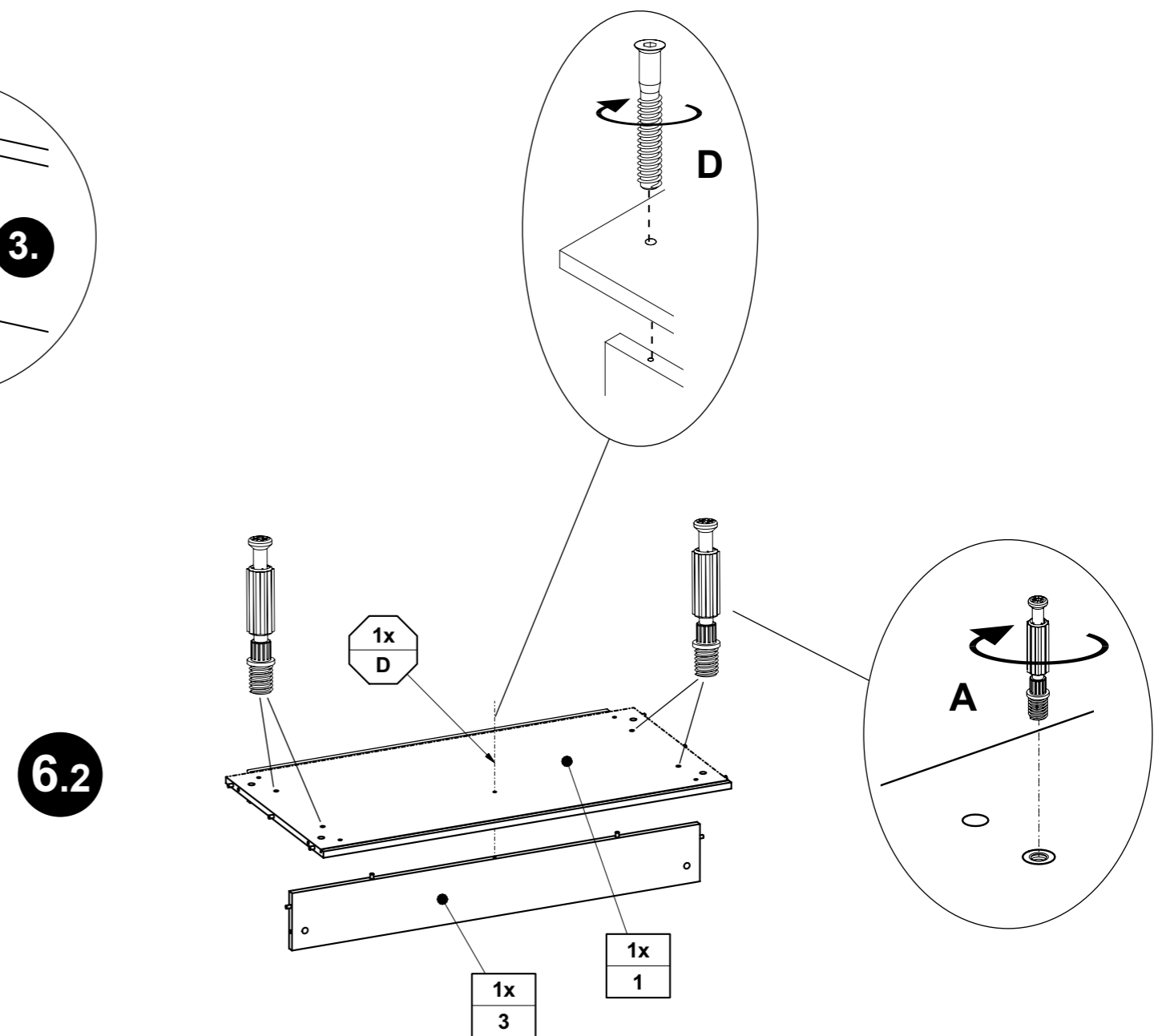
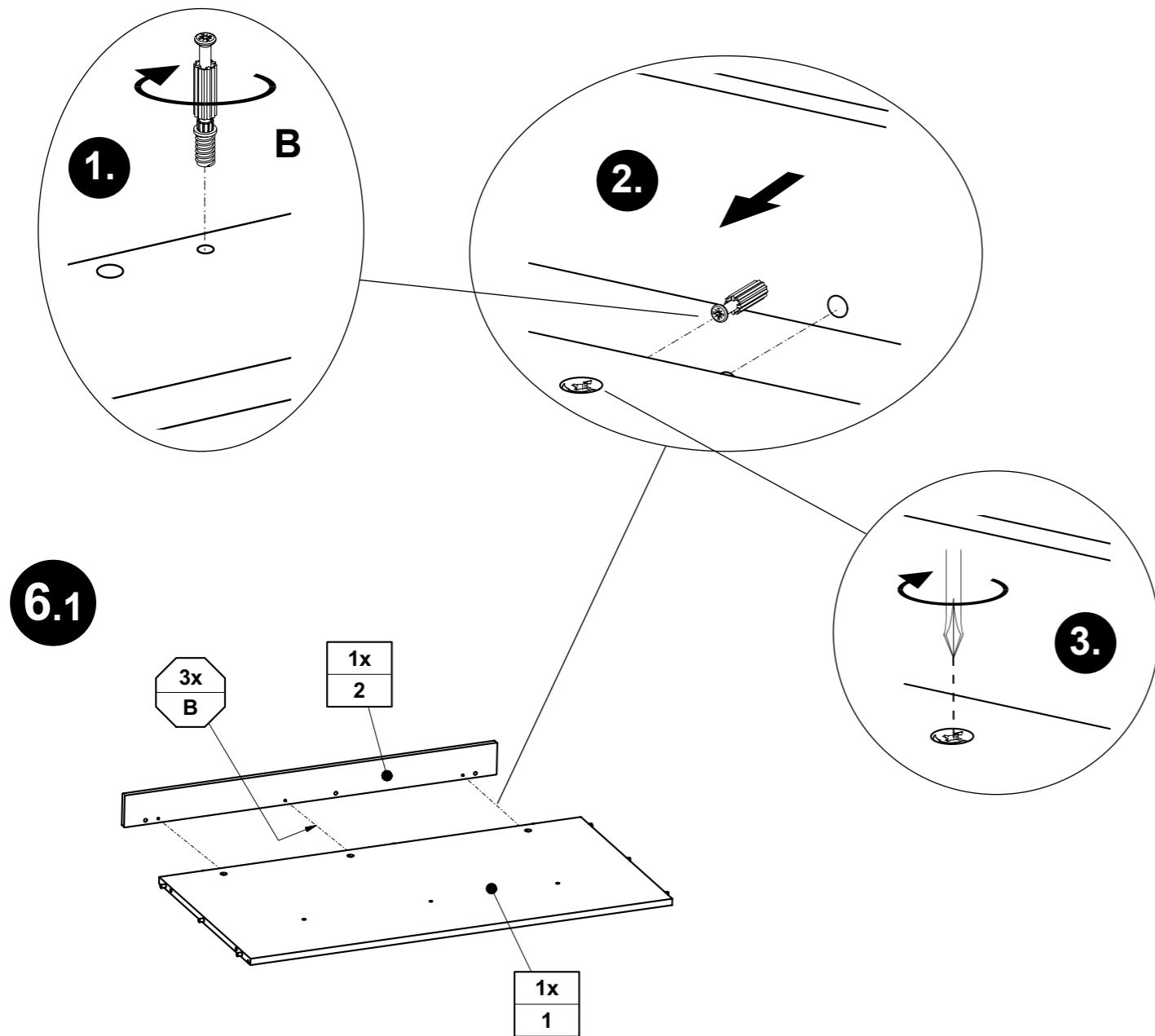

7

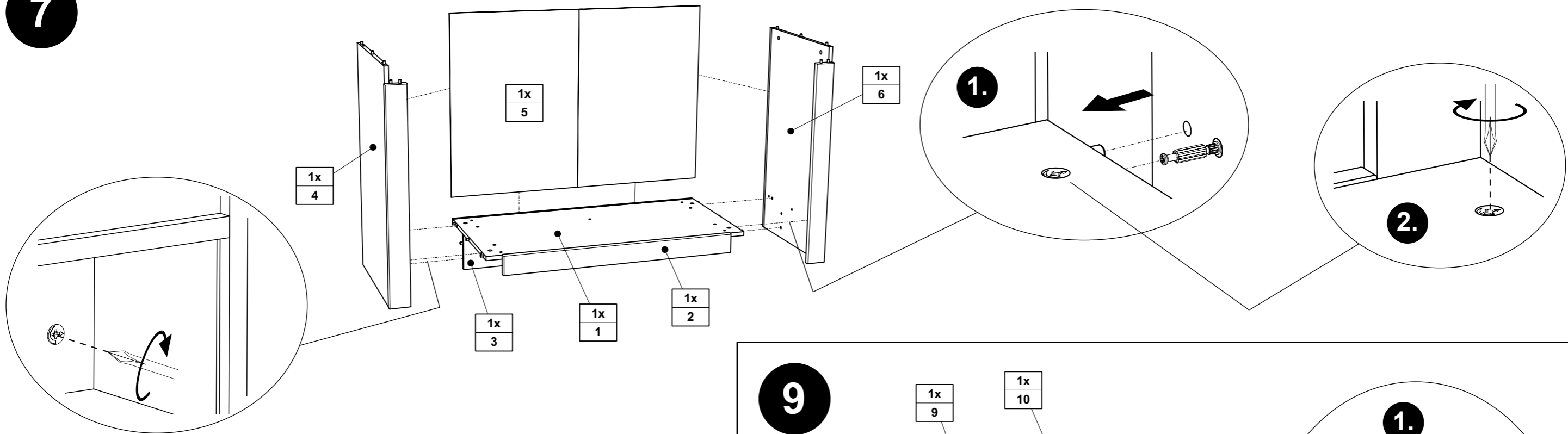

8

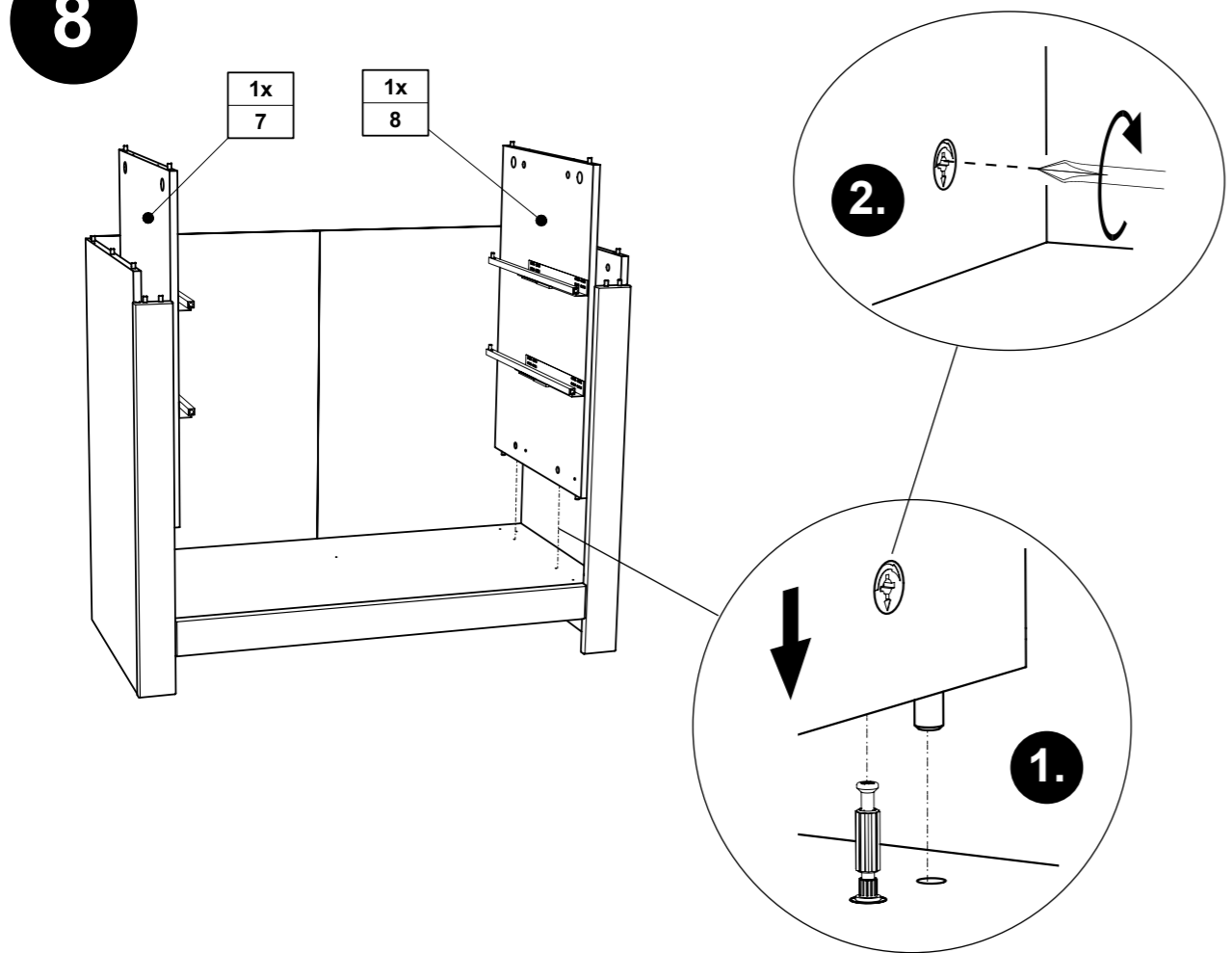

9

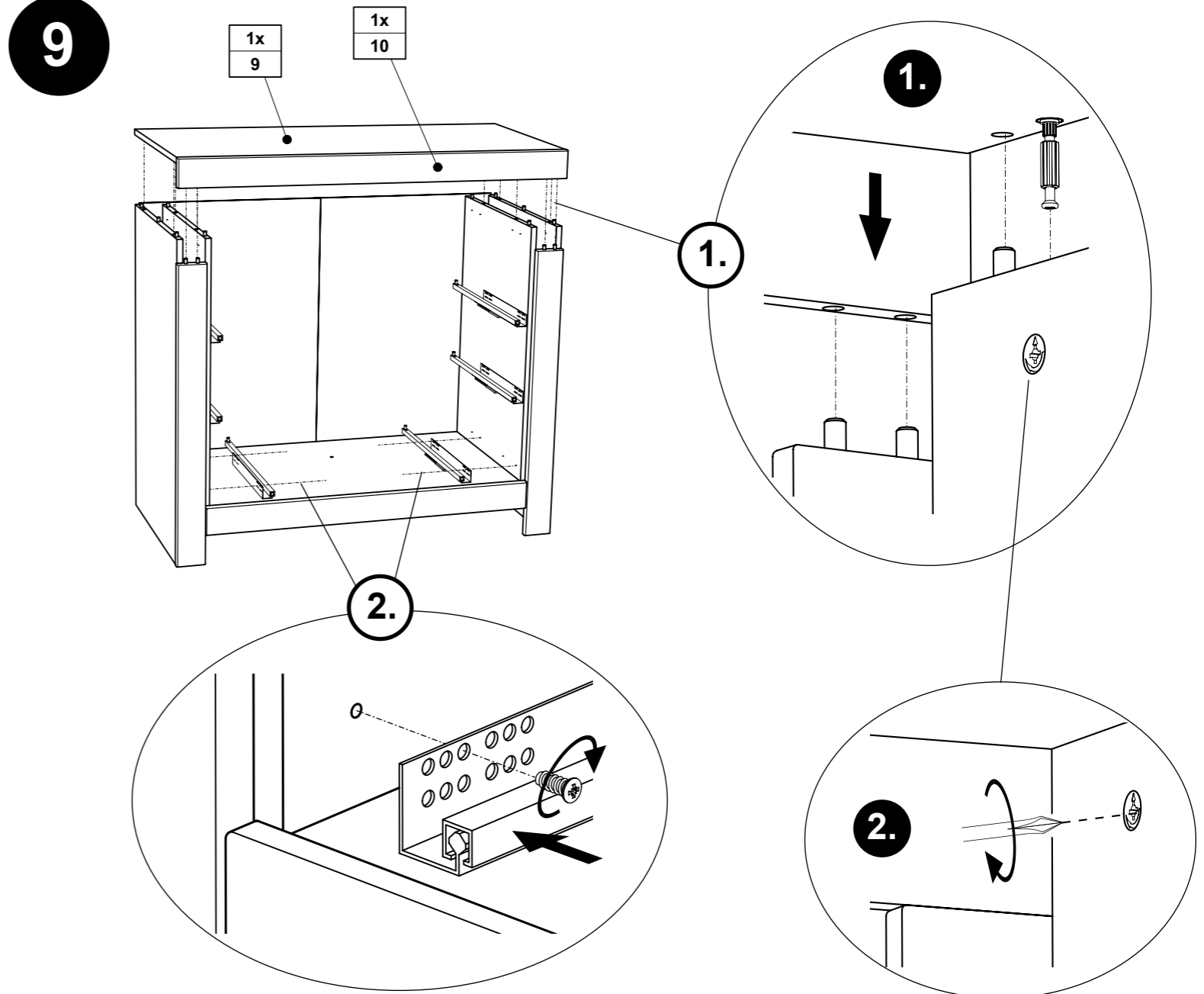

10

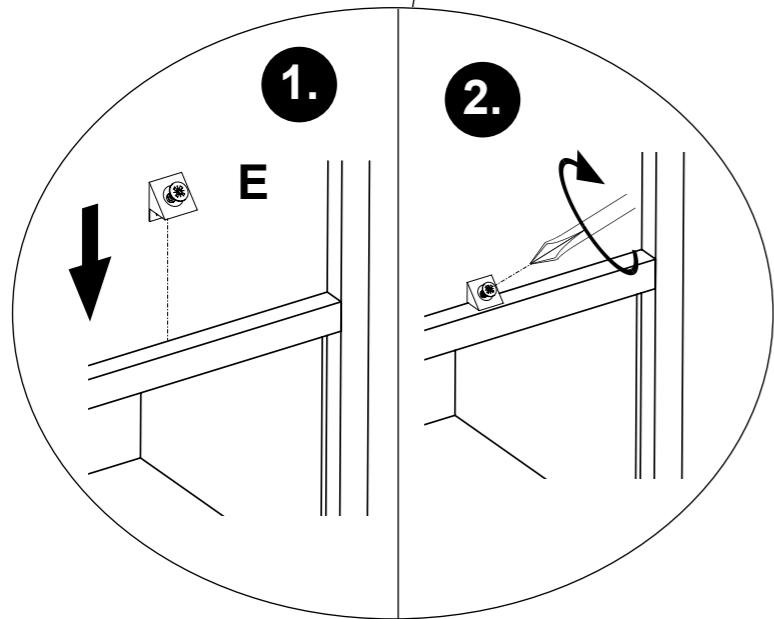
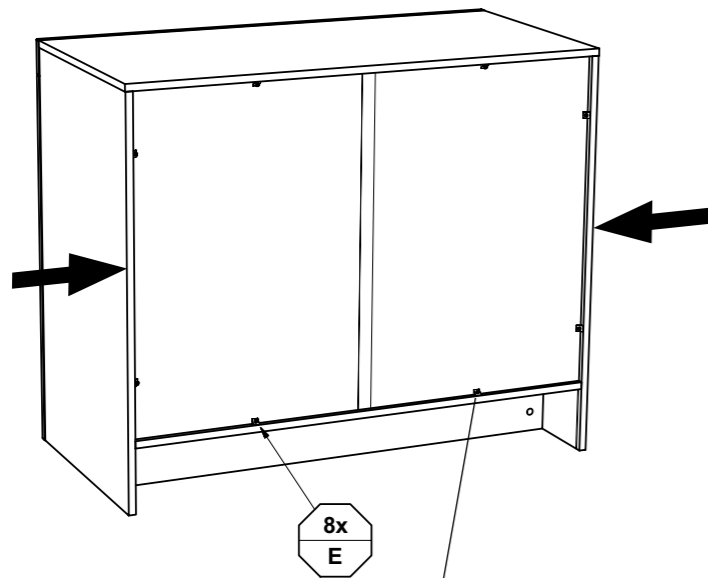

11

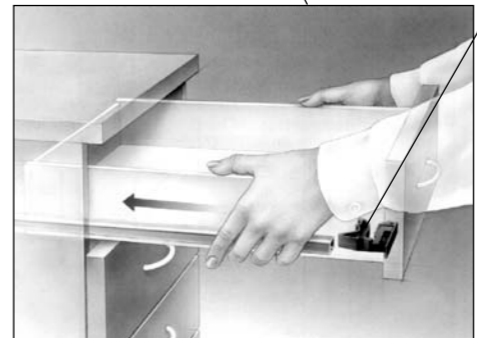
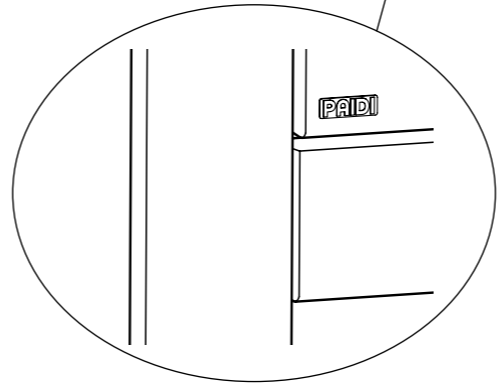
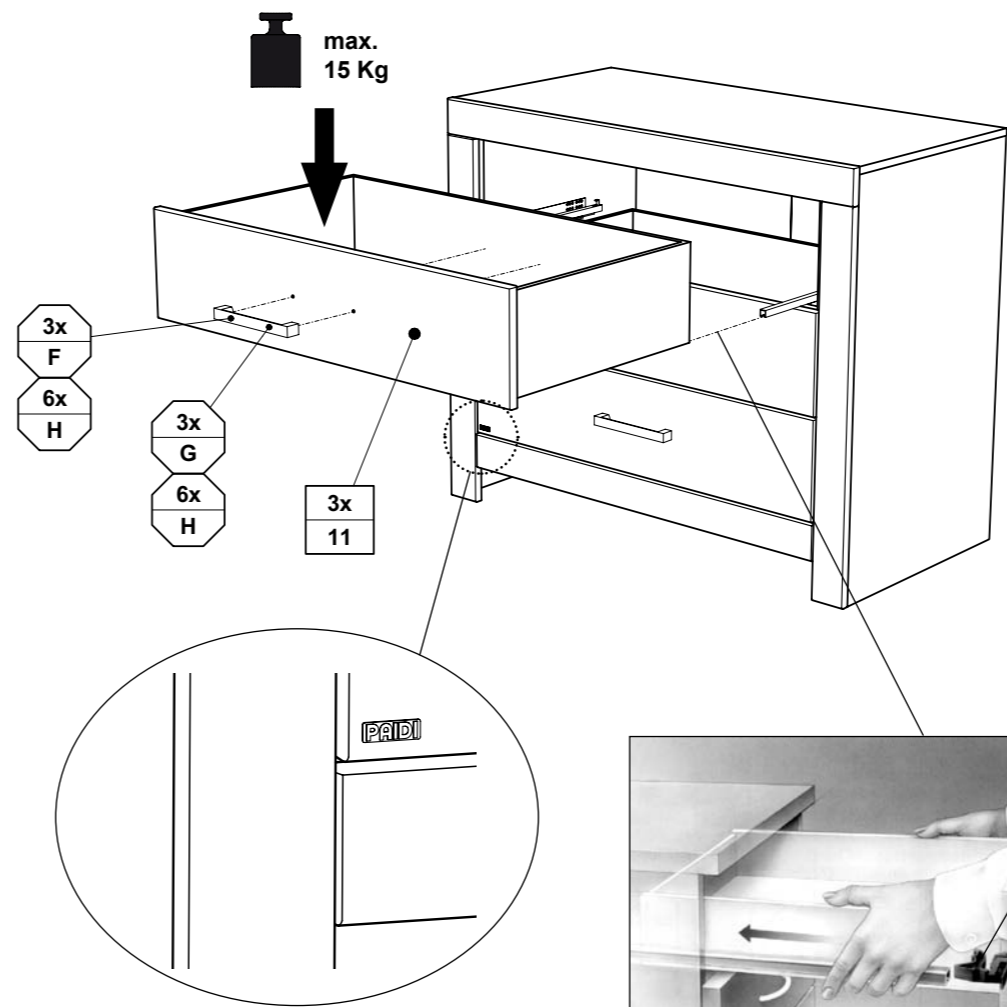

CLICK !!

Justierung der Schubkästen

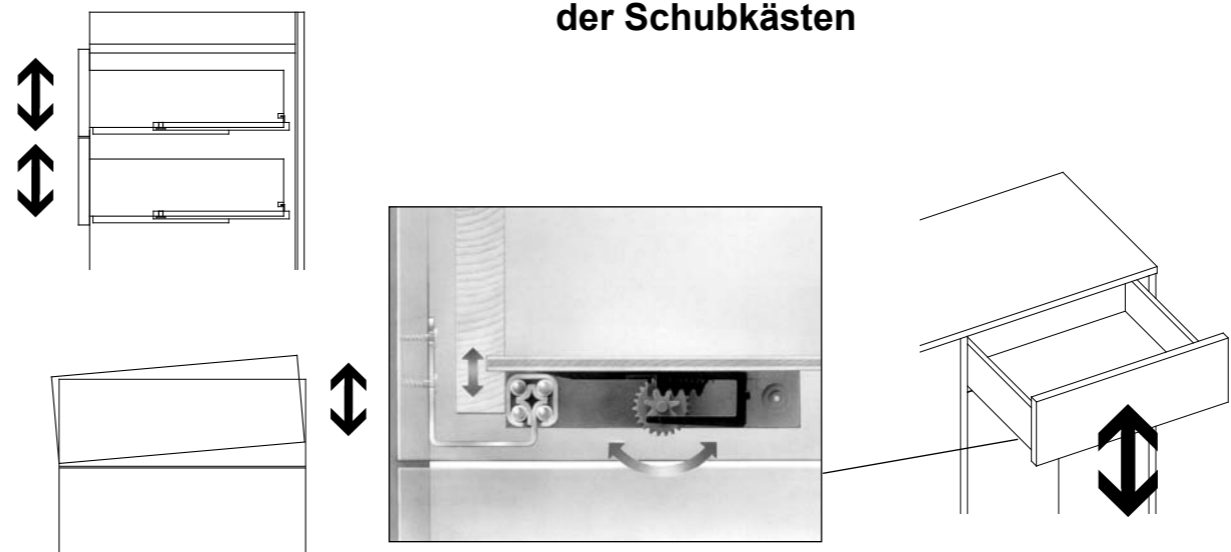

Demontage der Schubkästen

