

Gebrauchsanleitung / Instructions / Mode d'emploi / Gebruiksaanwijzing / Instrucciones

PAIDI
Möbel GmbH
Hauptstraße 87
D-97840 Hafenhof/Main

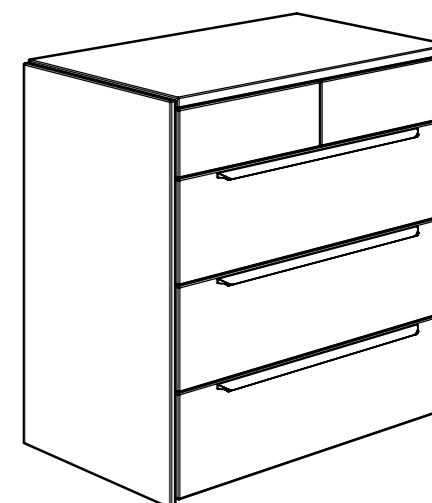

127 5481

1:1
DIN A3

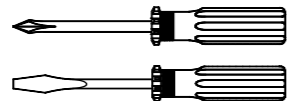
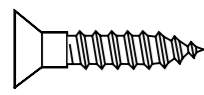
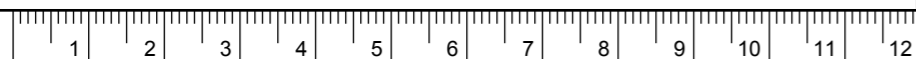

ca. 0,5h



A 10x 681 0759	B 1x 1x 681 8048	C 2x 8x 681 2498	D Griffleiste 1x 3x 3x 681 7325
---------------------------------	-----------------------------------	--------------------------------------	---

ACHTUNG !!
Entfernen Sie vor der Montage die
Schutzfolie von allen Teilen.

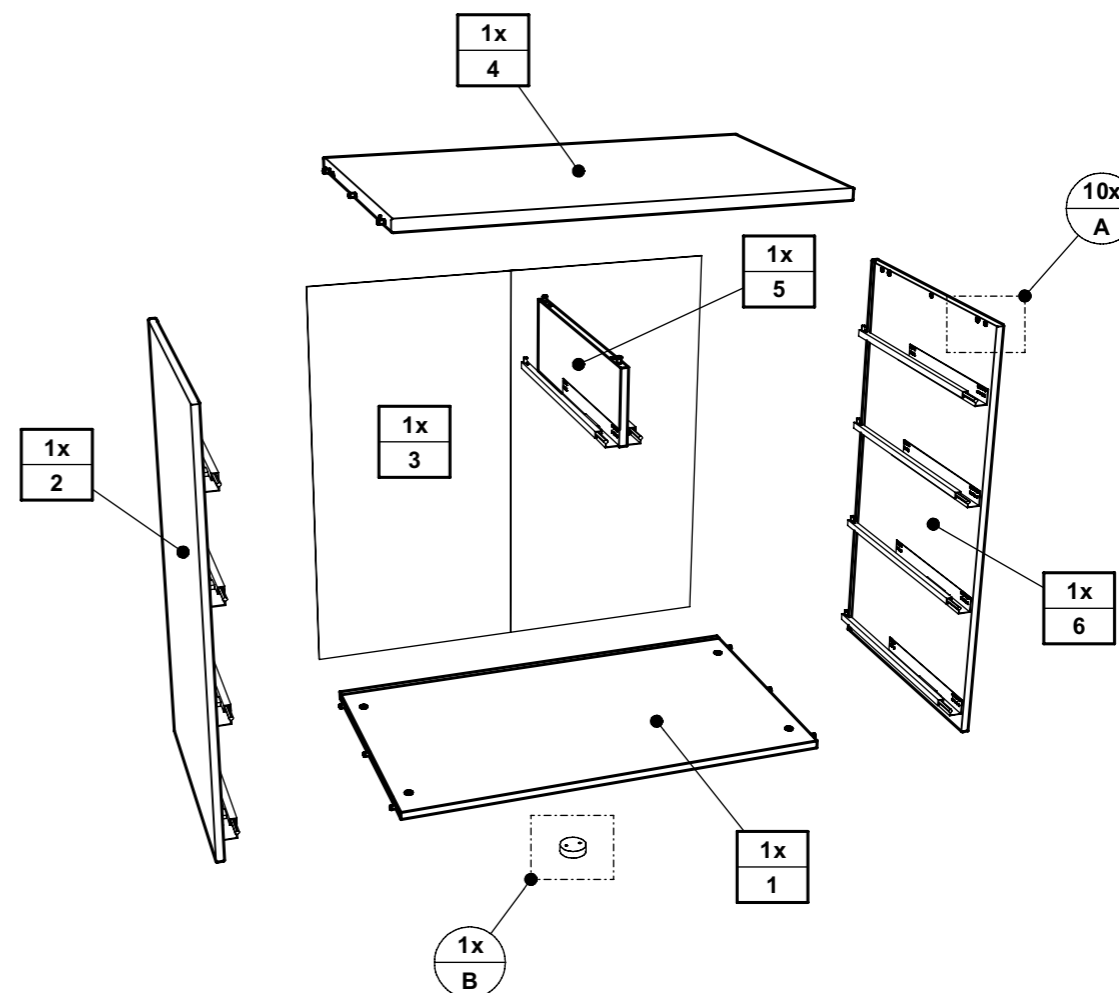
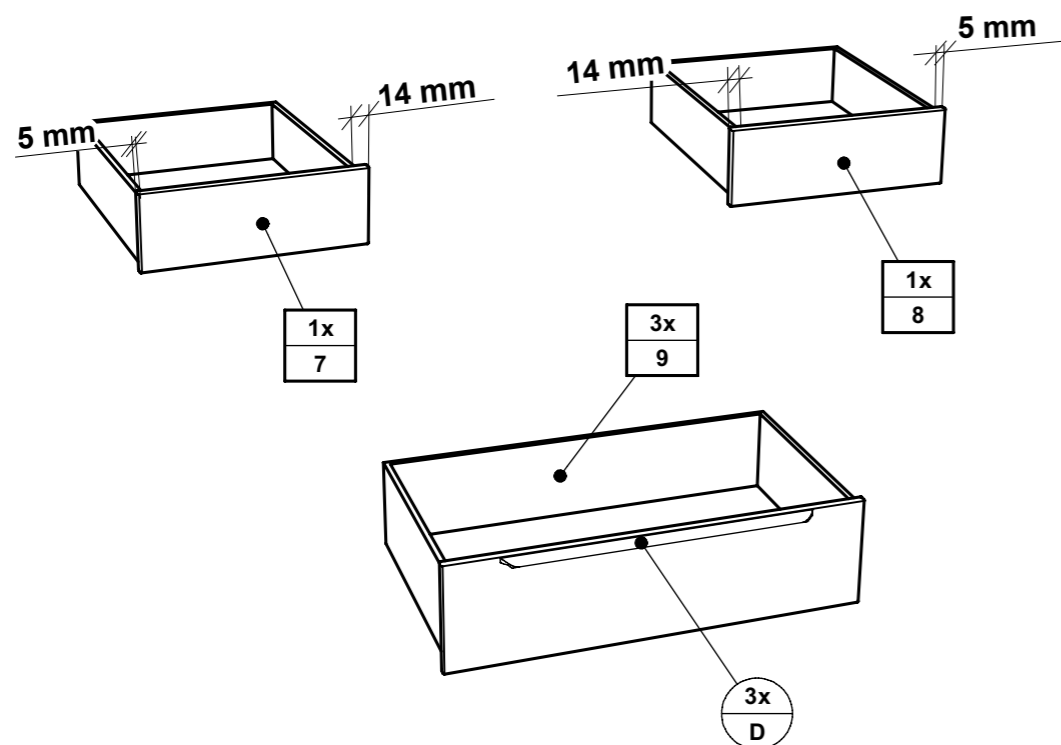
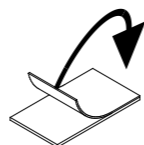

- DE Pflegehinweis:** Zum Reinigen der Oberflächen ein leicht-feuchtes Tuch oder ein handelsübliches Möbelpflegemittel verwenden.
- FR Indication sur l'entretien :** pour nettoyer les surfaces, utiliser un chiffon légèrement humide ou un nettoyant pour meubles en vente dans le commerce
- GB Caring for the... :** In order to clean the surfaces please use a slightly damp cloth or commercially available furniture care product.
- NL Verzorgingsaanwijzing:** Voor het reinigen van de oppervlakken een licht vochtig doek of een gebruikelijk meubelschoonmaakmiddel gebruiken.
- ES Recomendaciones de cuidado:** Para limpiar las superficies del mueble debe usar un trapo humedecido o un producto de limpieza de muebles comercial.
- GR Οδηγίες περιποίησης:** Για το καθαρίσμα των επιφανειών να χρησιμοποιείτε ένα ελαφρά νοτισμένο πανάκι ή λούστρο επίπλων.
- IT Indicazione per pulizia e cura:** Per la pulizia delle superfici utilizzate un panno leggermente umido o un normale prodotto per la cura dei mobili.
- CZ Pokyny k čištění:** Na čištění povrchu použijte pouze navlhčený kousek látky nebo běžný prostředek na ošetřování nábytku.
- SK Pokyn k ošetrovaniu:** Na čistenie povrchu používajte mierne navlhčenú handru alebo bežný čistiaci prostriedok na nábytok.
- SI Navodilo za nego:** Za čiščenje površin uporabljajte malo vlažno čunjo ali trgovsko običajno sredstvo za nego pohištva.
- DK Pleje:** Rens overflader med en fugtig klud eller et gængs møbelplejemiddel.
- SE Skötselråd:** Rengör ytorna med en fuktig trasa eller med ett vanligt möbelrengöringsmedel som finns i handeln.
- FI Hoito-ohje:** Käytä pintojen puhdistukseen kosteata pyyhettä tai yleisen kauppalaadun mukaista huonekalujen hoito-ainetta.
- PL Wskazówka pielęgnacyjna:** do czyszczenia powierzchni stosować lekko wilgotną ściereczkę lub zwykły środek do pielęgnacji mebli.
- HU Ápolási útmutatás:** A felületek tisztításához egy enyhén nedves kendőt, vagy kereskedelemben kapható, szokványos bútoralpoló szert használnjon.
- RO Indicații de întreținere:** pentru curățirea suprafețelor folosiți o cârpă umezită ușor sau un produs comercial obișnuit pentru îngrijirea mobilei.
- BG Указание за поддържане:** Използвайте леко навлажнена кърпа или обикновен препарат за поддържане на мебели, за да почистите повърхностите.
- HR Upute za njegu:** Za čišćenje površina upotrijebiti jednu lako navlaženu krpu i trgovačko uobičajeno sredstvo za njegu namještaja.
- LT Rekomendacija priežiūrai:** Paviršius valykite drėgna pašluoste arba parduotuvėse įsigytomis baldų priežiūros priemonėmis.
- RU Рекомендации по уходу:** для очистки поверхностей используйте слегка влажную тряпку или обычное средство по уходу за мебелью.
- CN 保养说明:** 清洁表面只需用稍微潮湿的布或普通的家具清洁剂即可。

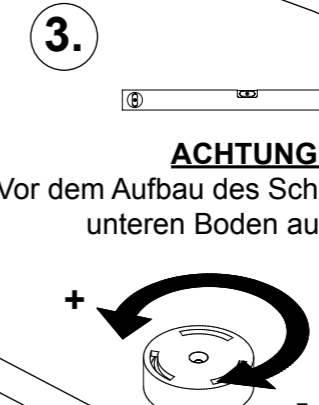
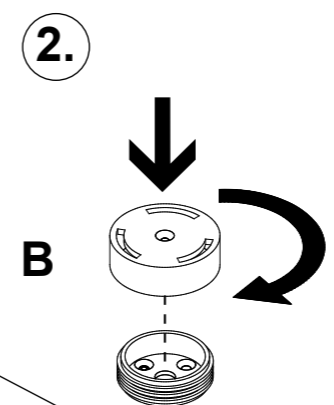
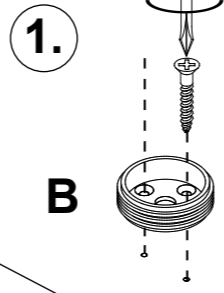
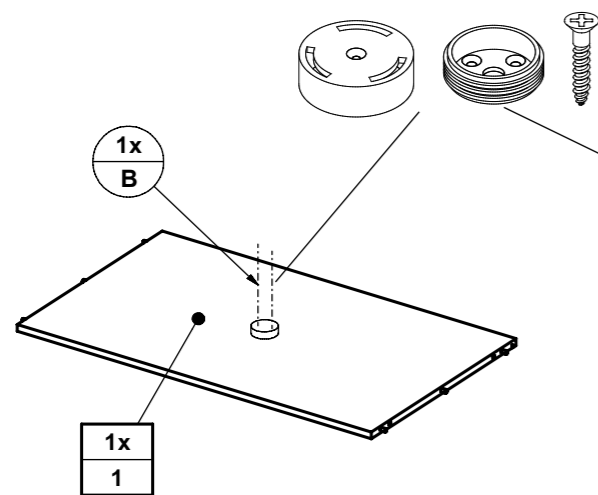

3.
ACHTUNG !!
Vor dem Aufbau des Schrankes erst den unteren Boden ausrichten.

CAUTION! Before assembling the wardrobe you should first align the bottom shelf.
ATTENTION! Orienter le fond inférieur avant de monter le placard.
Opgelet! Vóór de opbouw van de kast eerst de onderste legplank uitlijnen.
Atención! Antes del montaje del armario nivele el suelo.

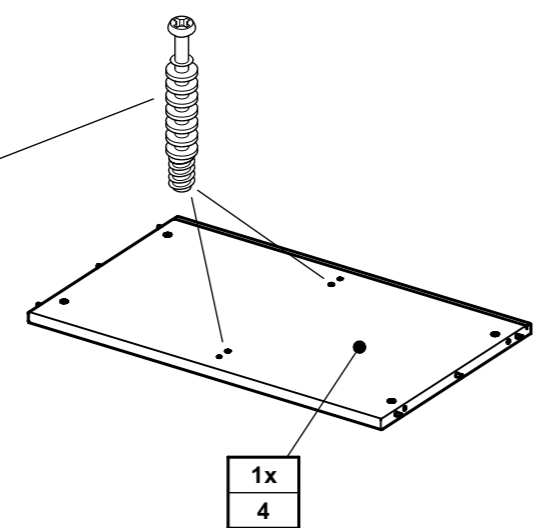
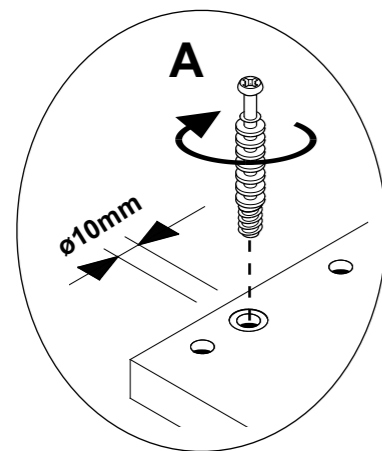

ACHTUNG !!
Vor dem Aufbau der Kommode erst den unteren Boden ausrichten.

CAUTION! Before assembling the wardrobe you should first align the bottom shelf.
ATTENTION! Orienter le fond inférieur avant de monter le placard.
Opgelet! Vóór de opbouw van de kast eerst de onderste legplank uitlijnen.
Atención! Antes del montaje del armario nivele el suelo.

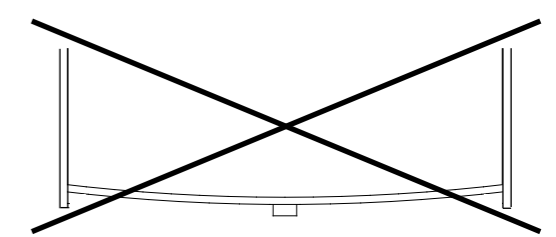
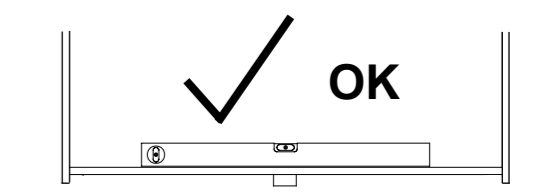
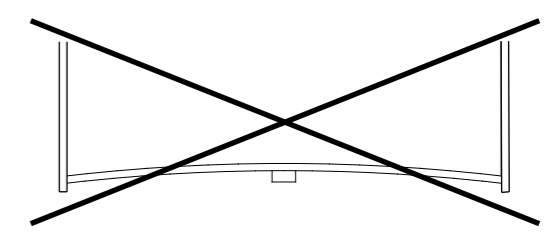
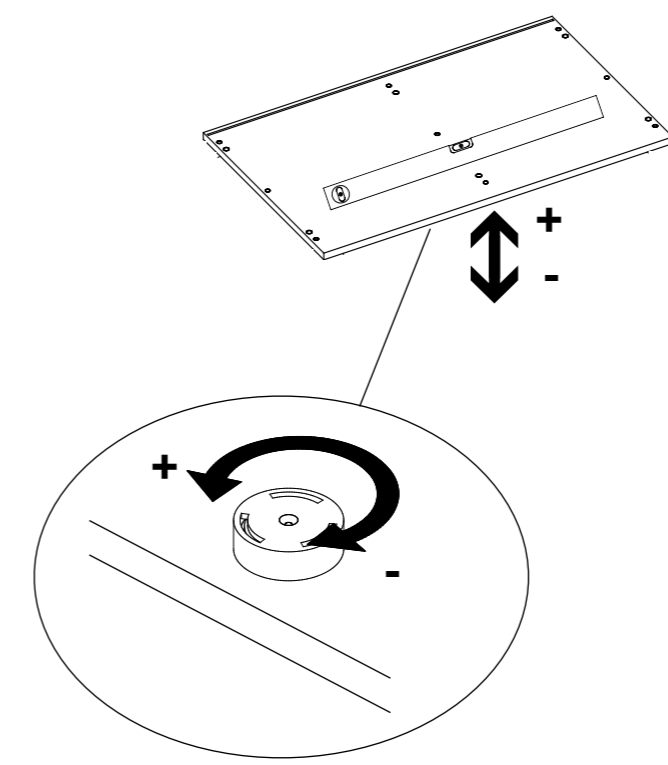
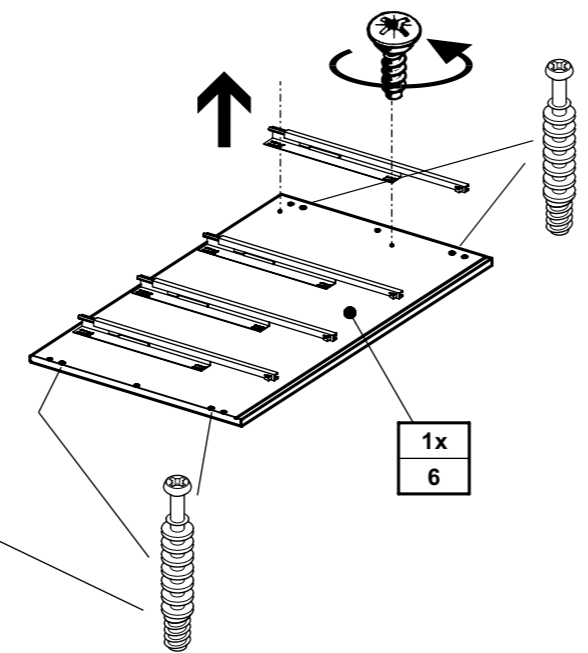
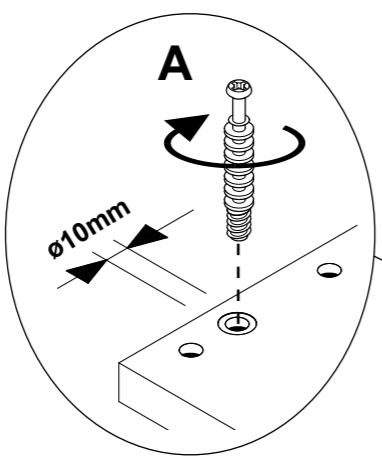
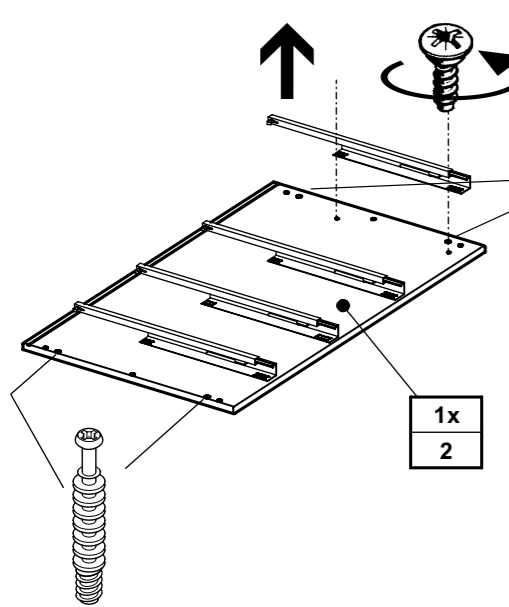

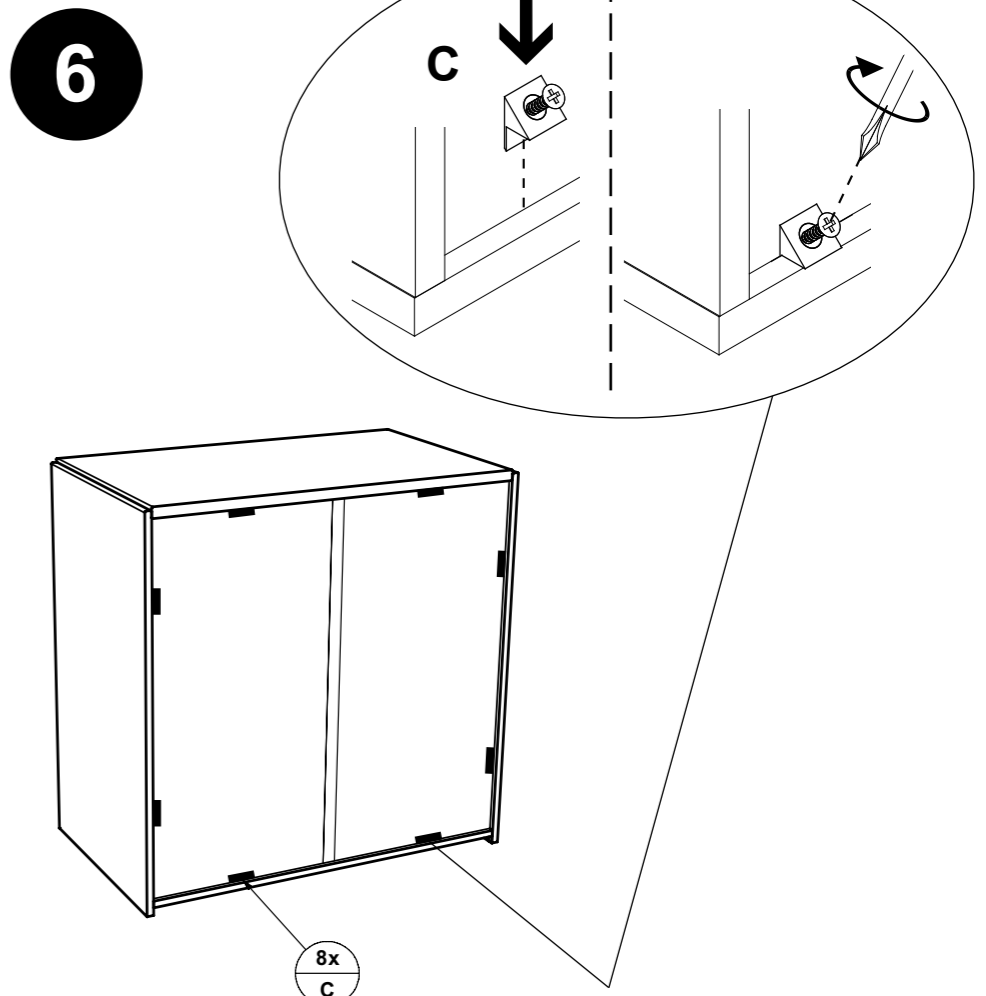
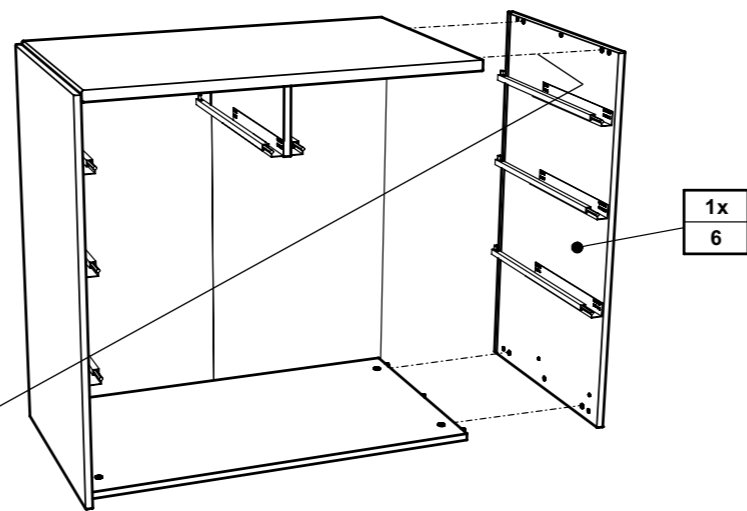
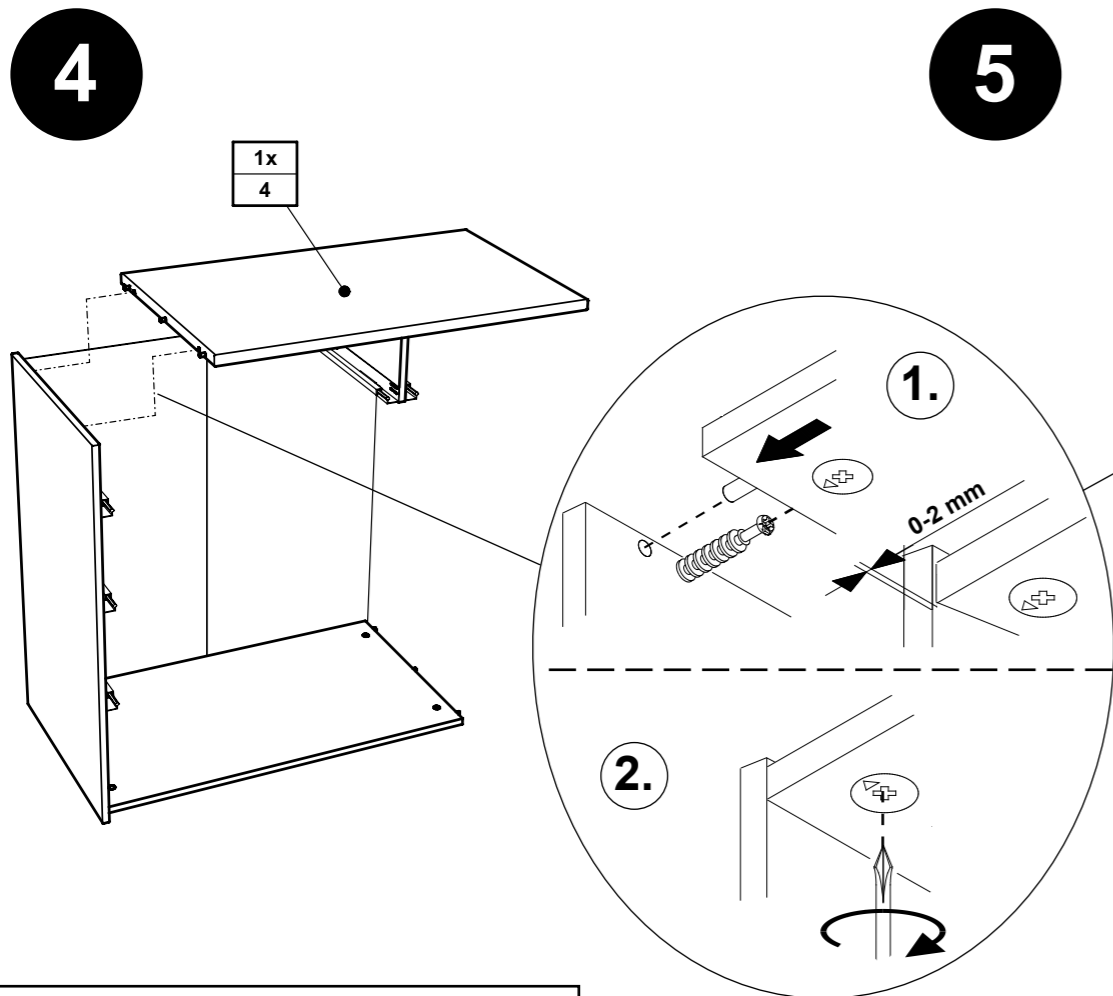
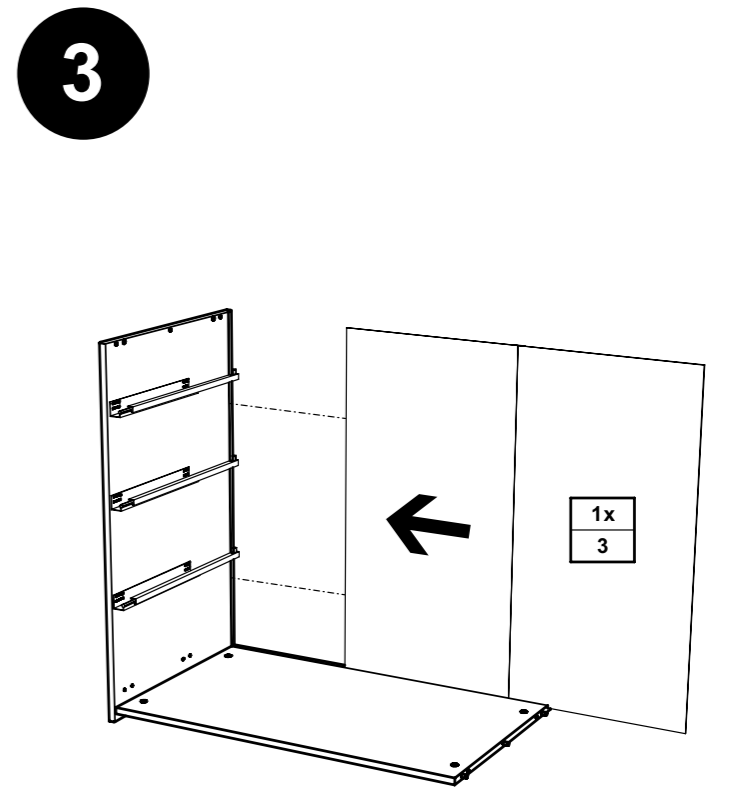
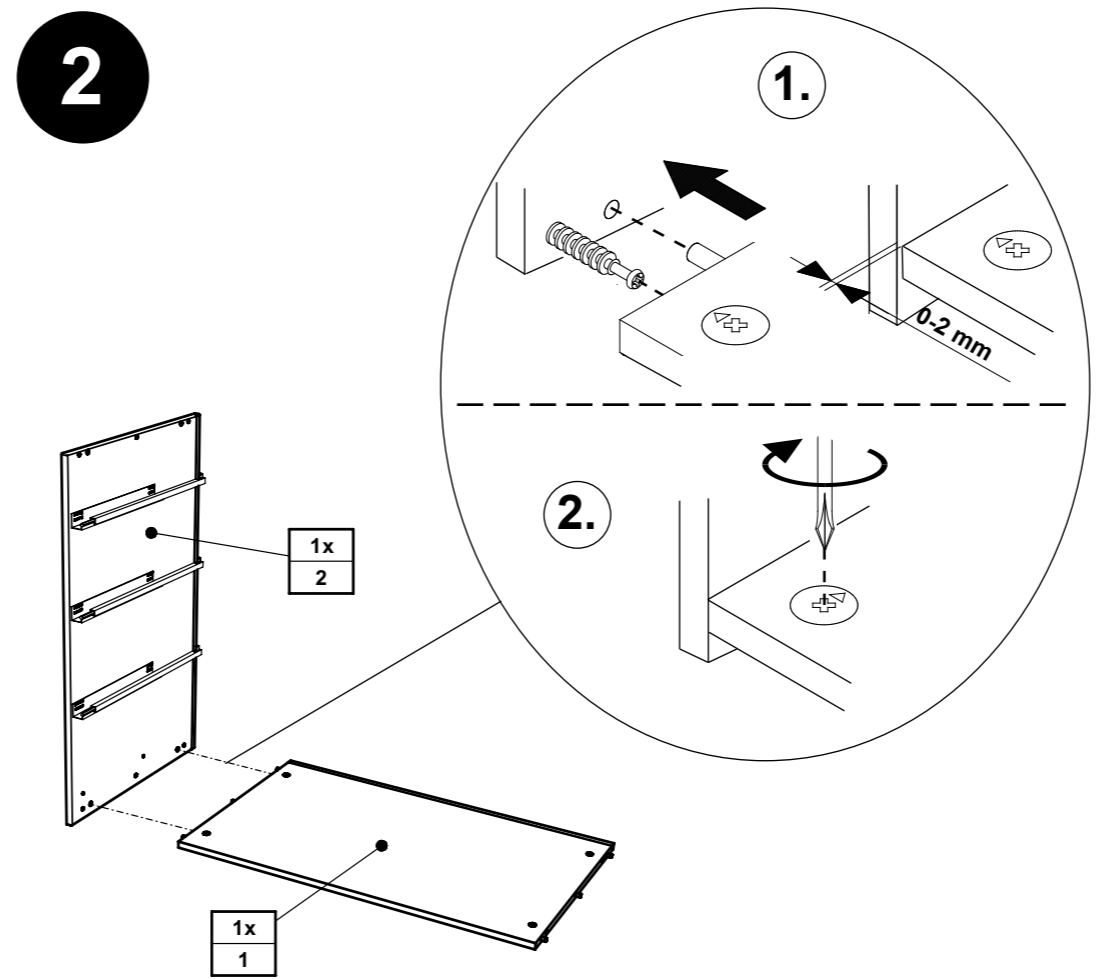
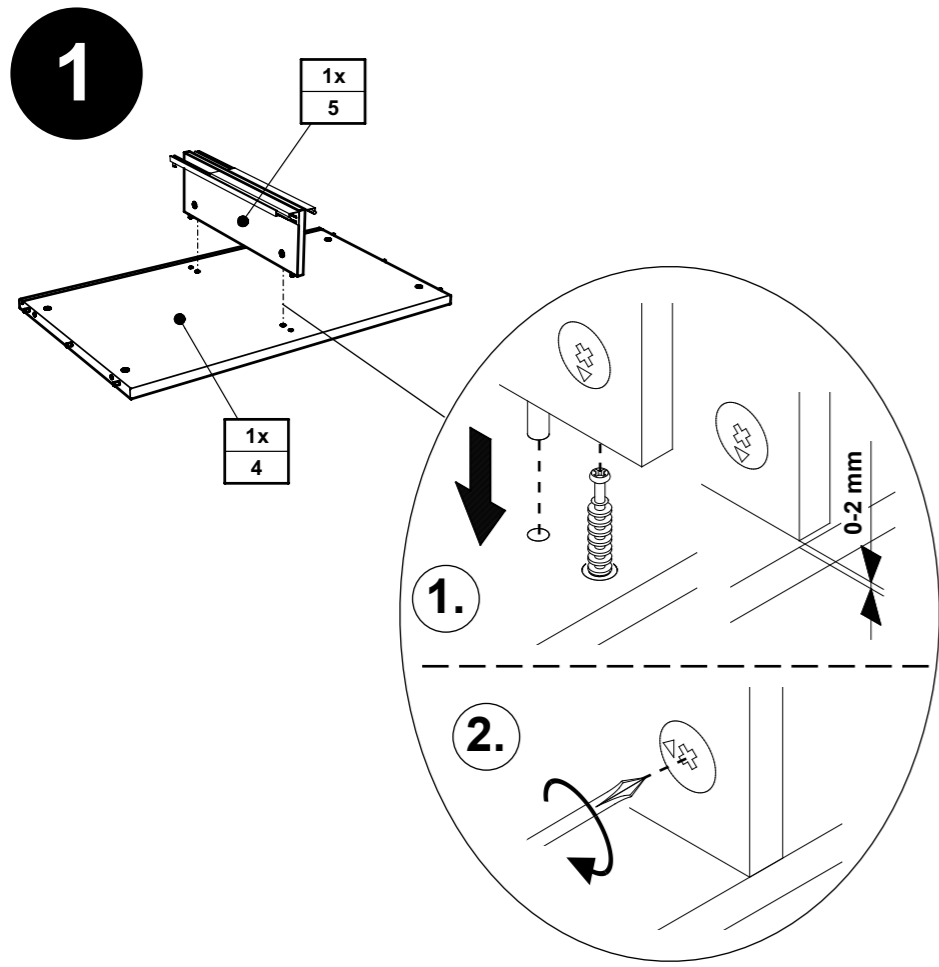

7

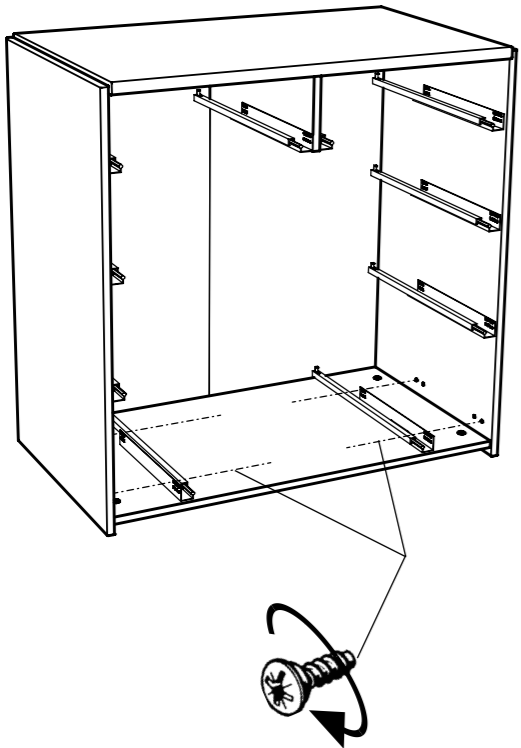

8

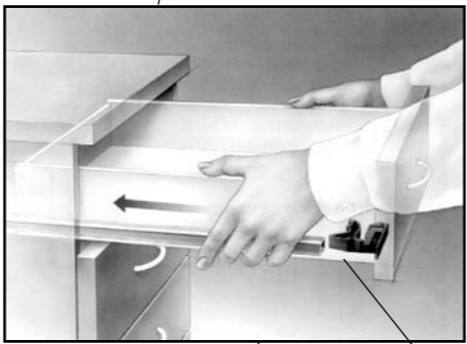
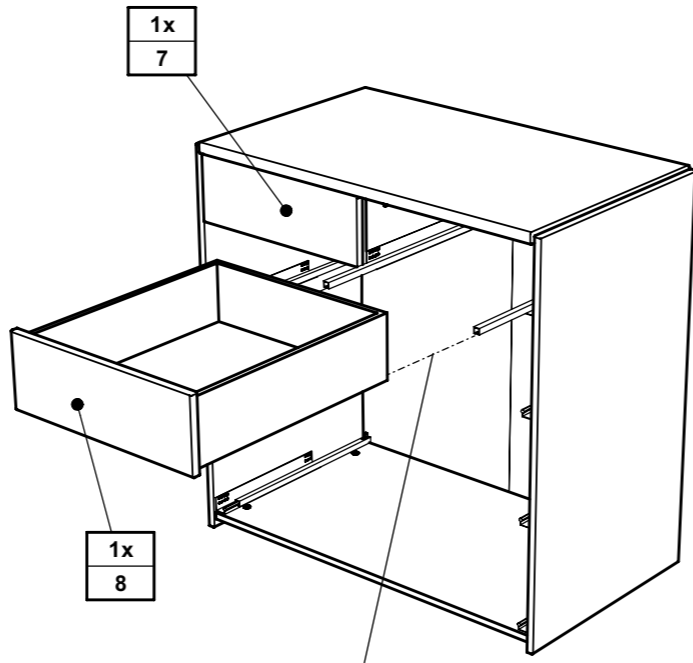

9

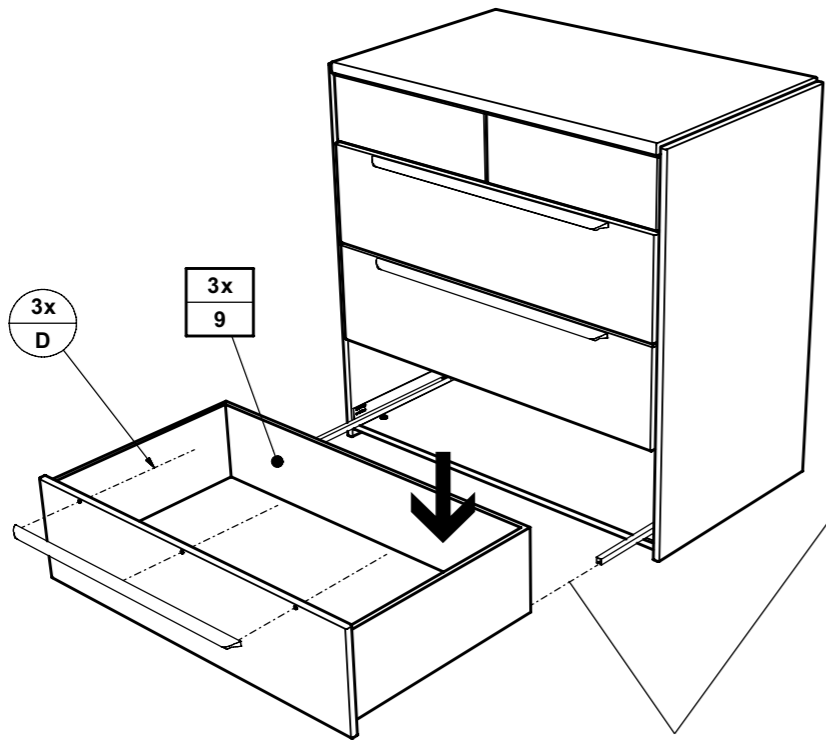

CLICK !!

Justierung der Schubkästen

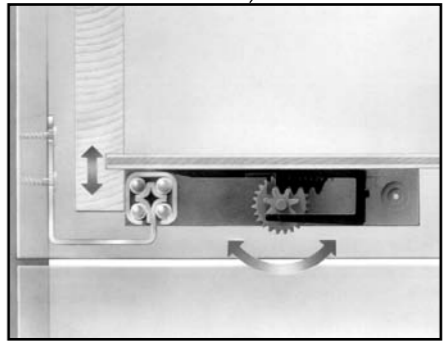
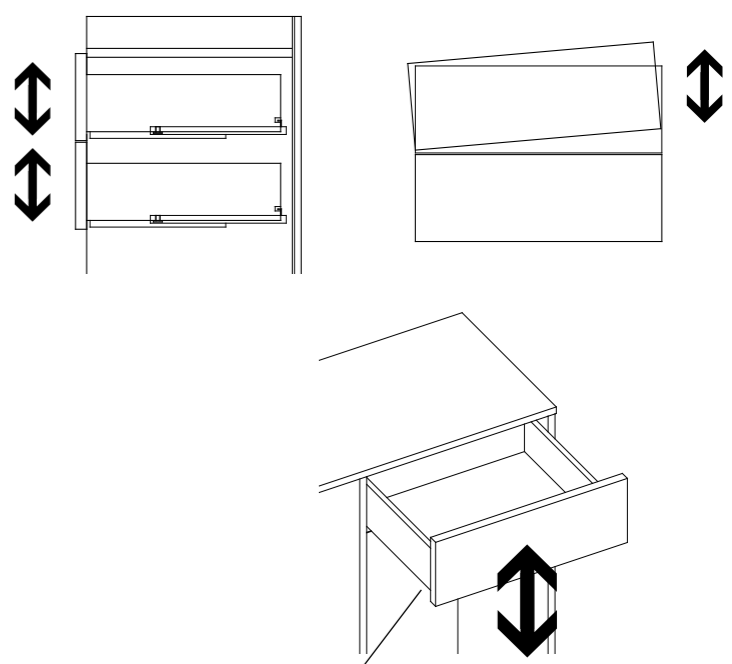

Demontage der Schubkästen

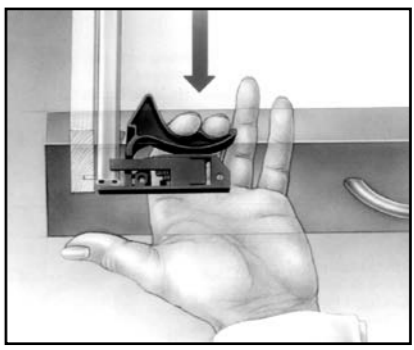



127 5181

127 5481

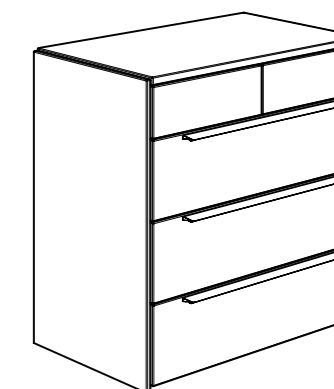
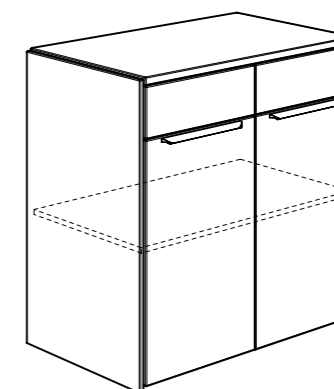

127 5181

127 5481

1:1
DIN A3

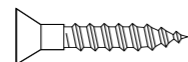

A

Griffleiste

1x 2x
2x 671 7355

A

Griffleiste

1x 3x
3x 671 7354

ACHTUNG !!
Entfernen Sie die **Schutzfolie** von allen Teilen.

ACHTUNG !!

Vor dem Aufstellen der Kommoden erst den unteren Boden ausrichten.

CAUTION! Before assembling the wardrobe you should first align the bottom shelf.
ATTENTION! Orienter le fond inférieur avant de monter le placard.
Opgelet! Vóór de opbouw van de kast eerst de onderste legplank uitlijnen.
Atención! Antes del montaje del armario nivele el suelo.

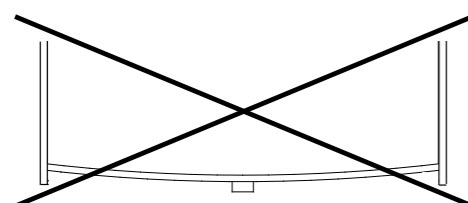
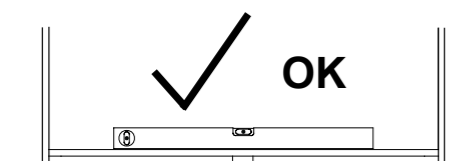
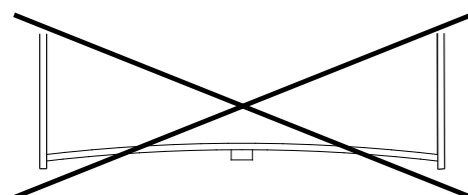
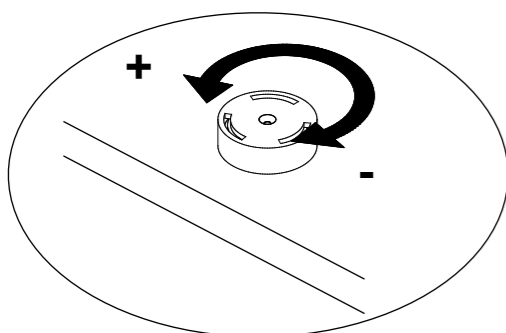

Demontage der Schubkästen

dismounting of drawers Démontage des tiroirs
demontage van de laden Desmontaje de las cajones

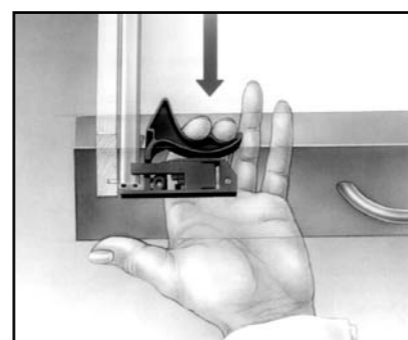

Justierung der Schubkästen

Adjustment of drawers Ajustement des tiroirs
Uitlijnen van de laden Ajuste de las cajones

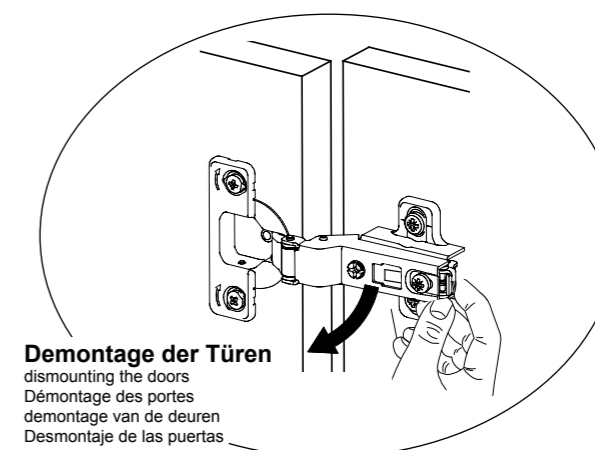
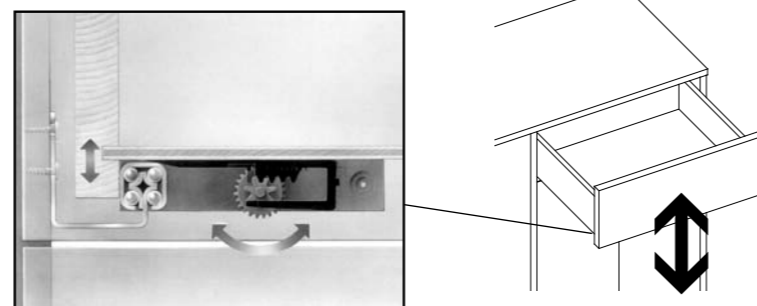
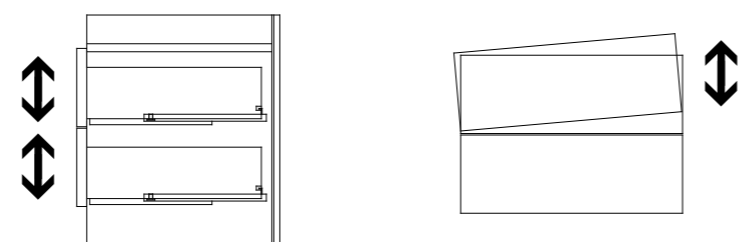

Demontage der Türen
dismounting the doors
Démontage des portes
demontage van de deuren
Desmontaje de las puertas

Justierung der Türen

Adjustment of doors
Ajustement des portes
Uitlijnen van de deuren
Ajuste de las puertas

