

**Gebrauchsanleitung / Instructions / Mode d'emploi /
Gebruiksaanwijzing / Instrucciones**

PAIDI
Möbel GmbH
Hauptstraße 87
D-97840 Hafenhöhr/Main



ALESSIA
125 1154

HENRIK
127 1144
HENRIK
127 1148

1:1
DIN A3

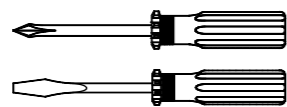
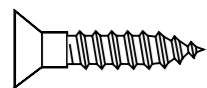
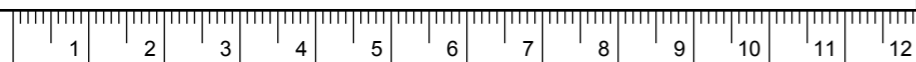

ca. 1,5h



A 18x 681 0759	B 4x 681 1645	C 4x 681 4887	D 11x 681 5311	E 1x 681 3011	F 6x 681 2588
---------------------------------	--------------------------------	--------------------------------	---------------------------------	--------------------------------	--------------------------------

H 4x 681 2497	I 4x 681 5060	J 8x 681 2498	K 9x 681 4914	L 12x 681 0350	Z 6x 681 2552
--------------------------------	--------------------------------	--------------------------------	--------------------------------	---------------------------------	--------------------------------

125 1154

M 2x 681 7292	N 4x 681 4910
--------------------------------	--------------------------------

127 1144 + 127 1148

M 2x 681 7295	M 2x 681 7229	N 4x 681 3806
--------------------------------	--------------------------------	--------------------------------

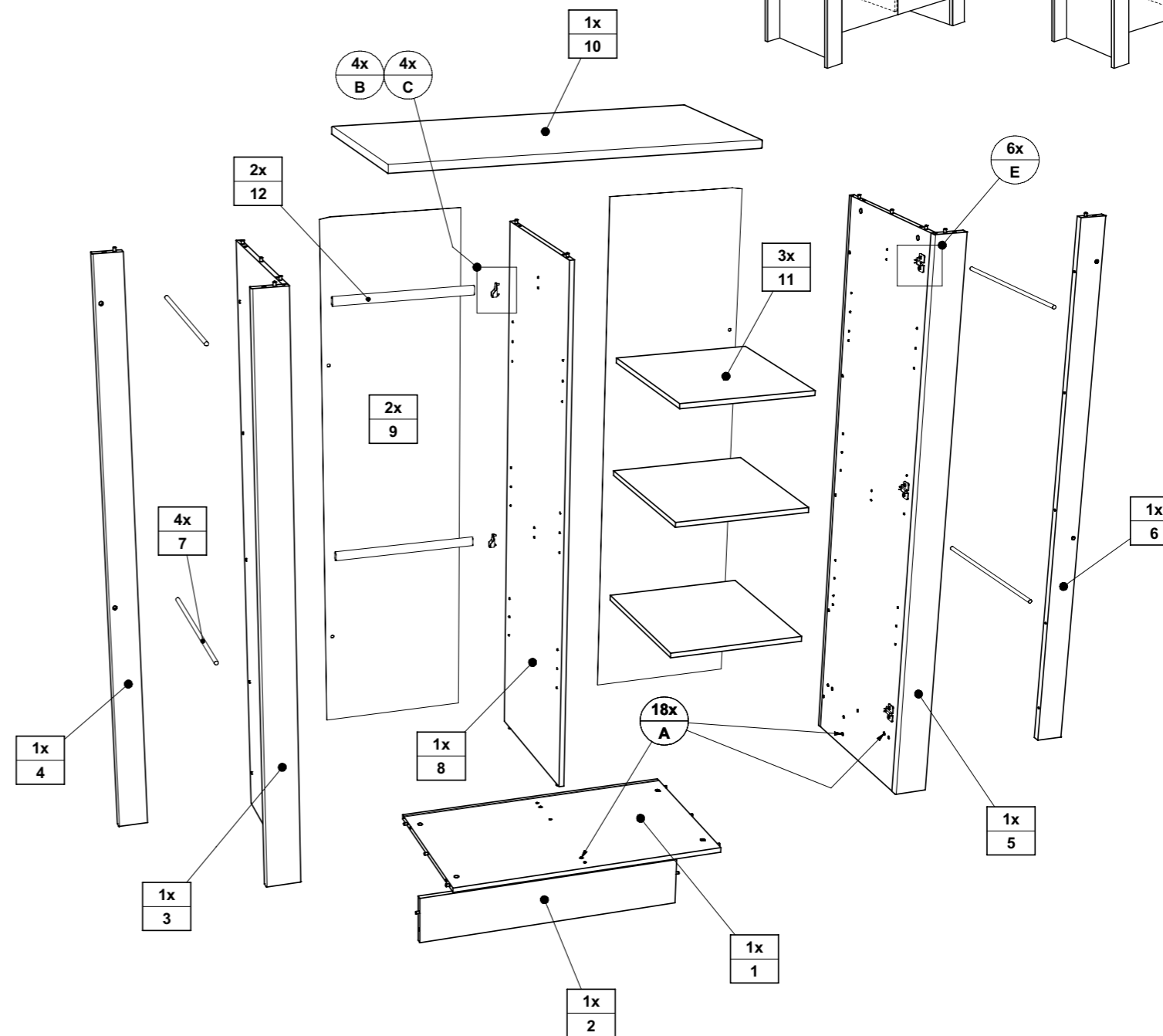
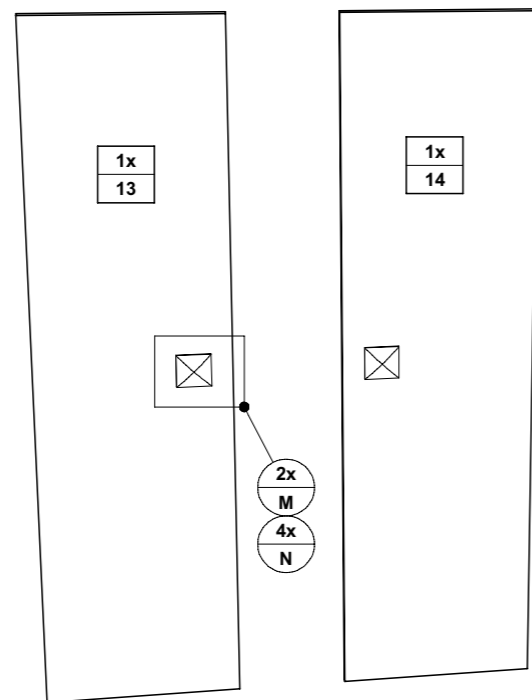

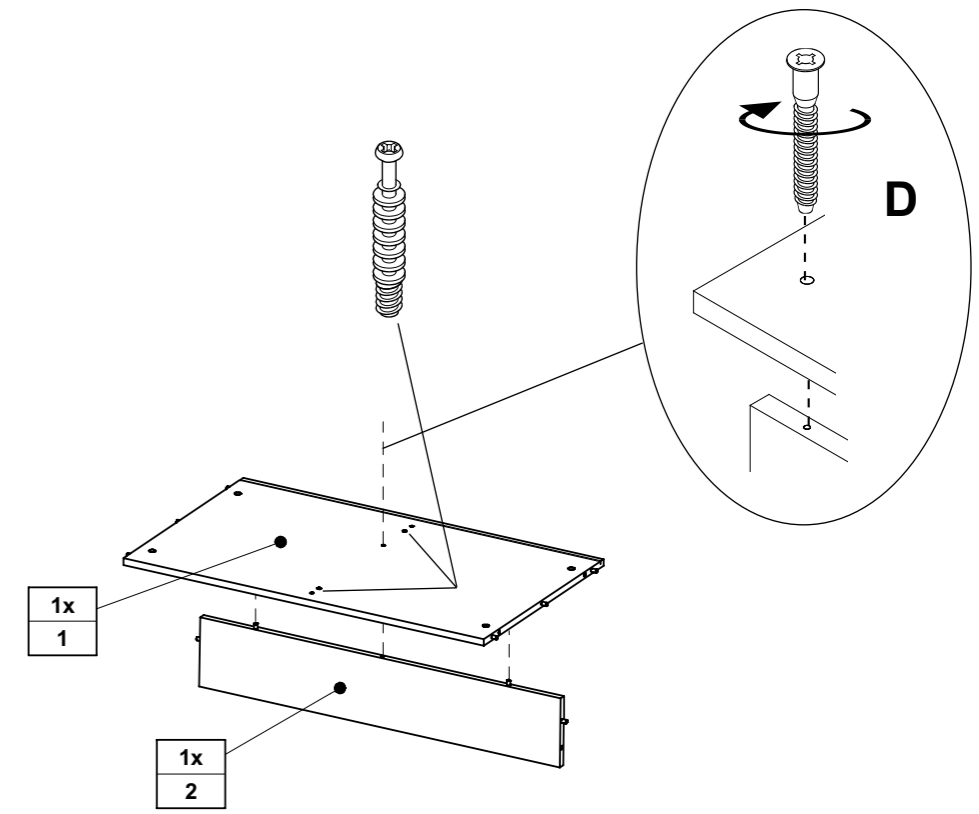
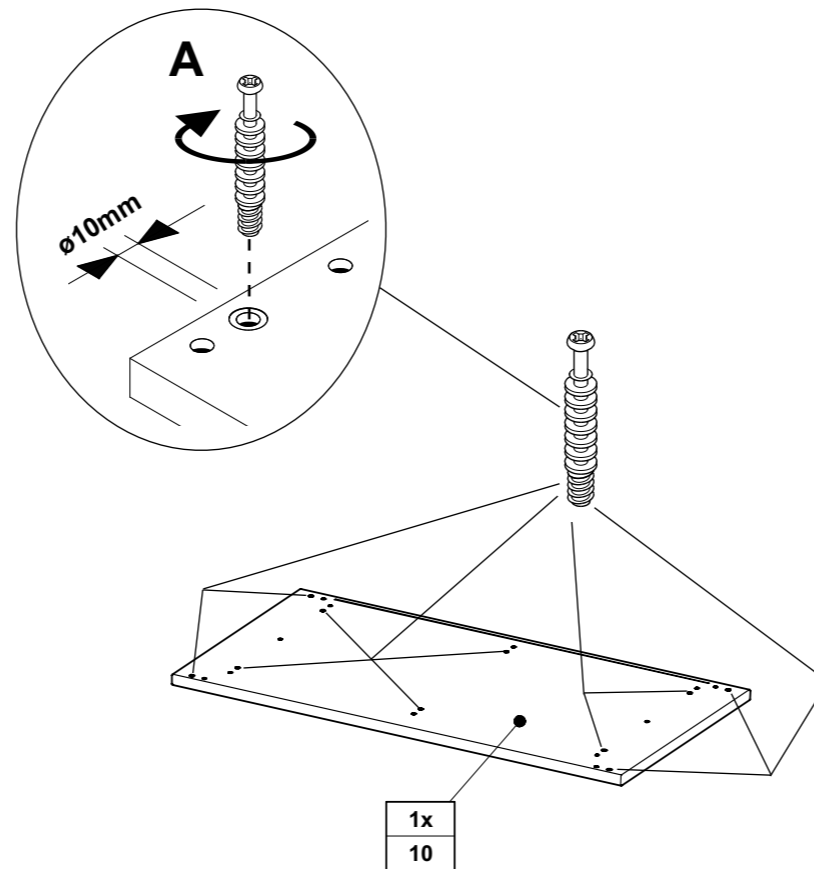
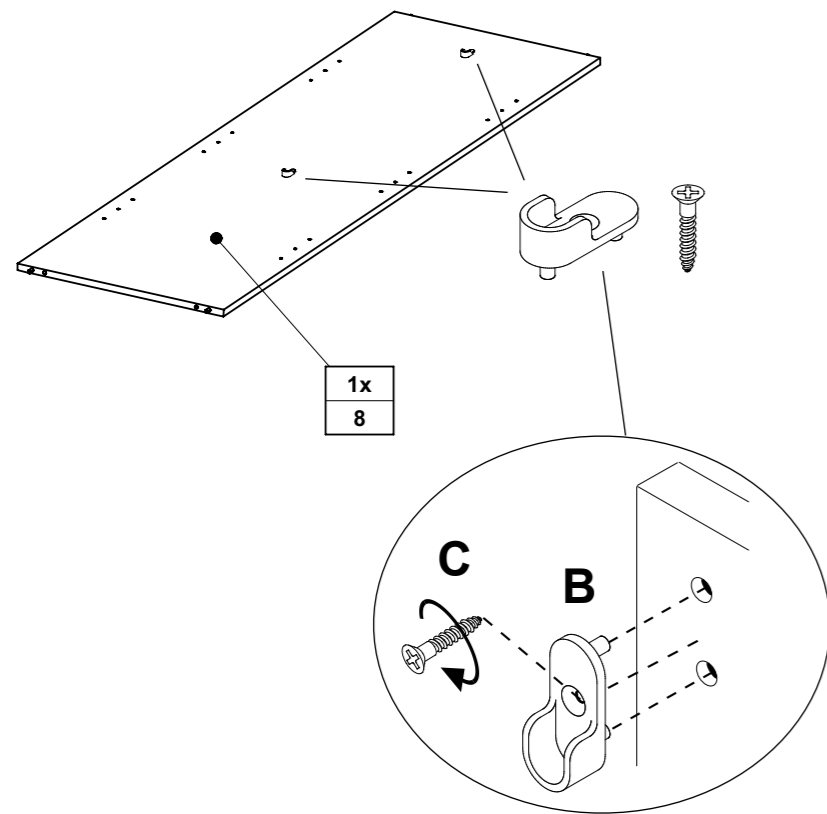
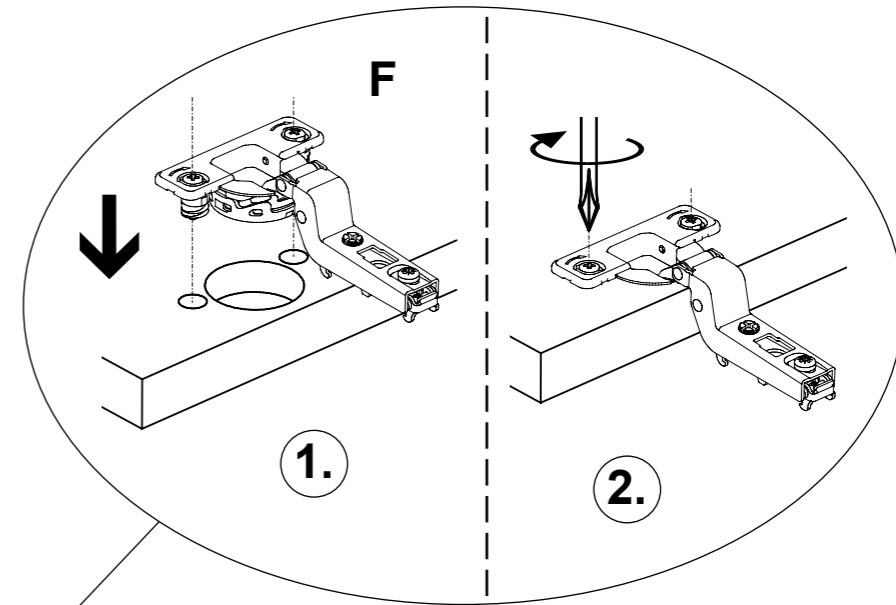
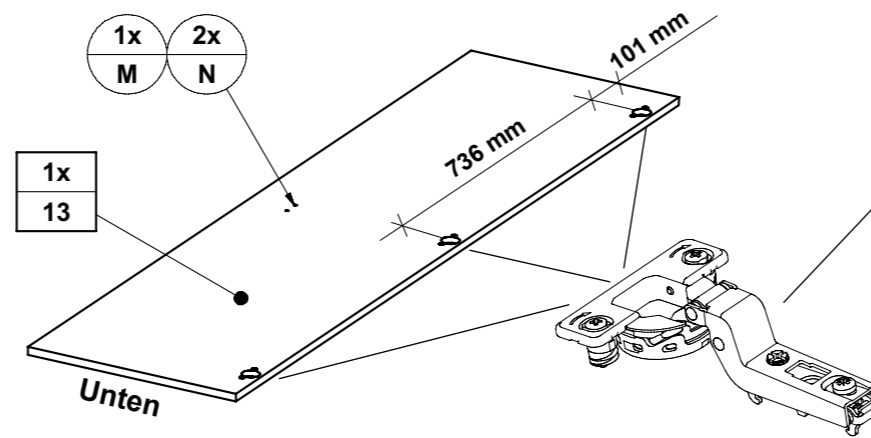
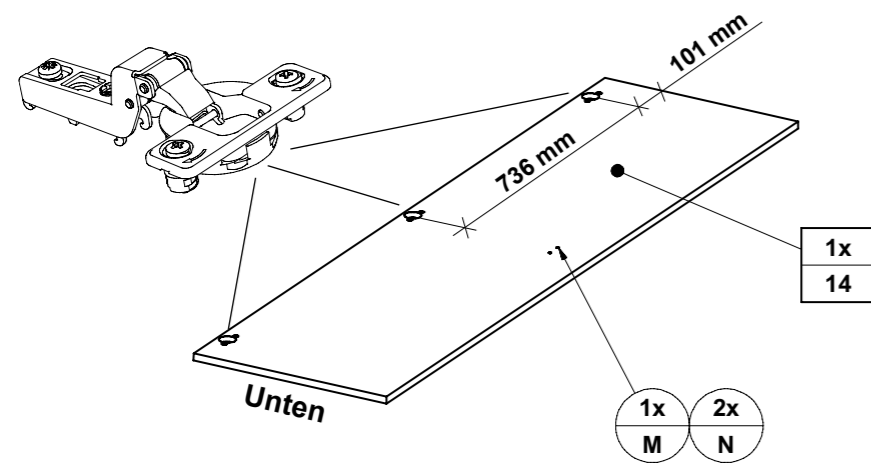

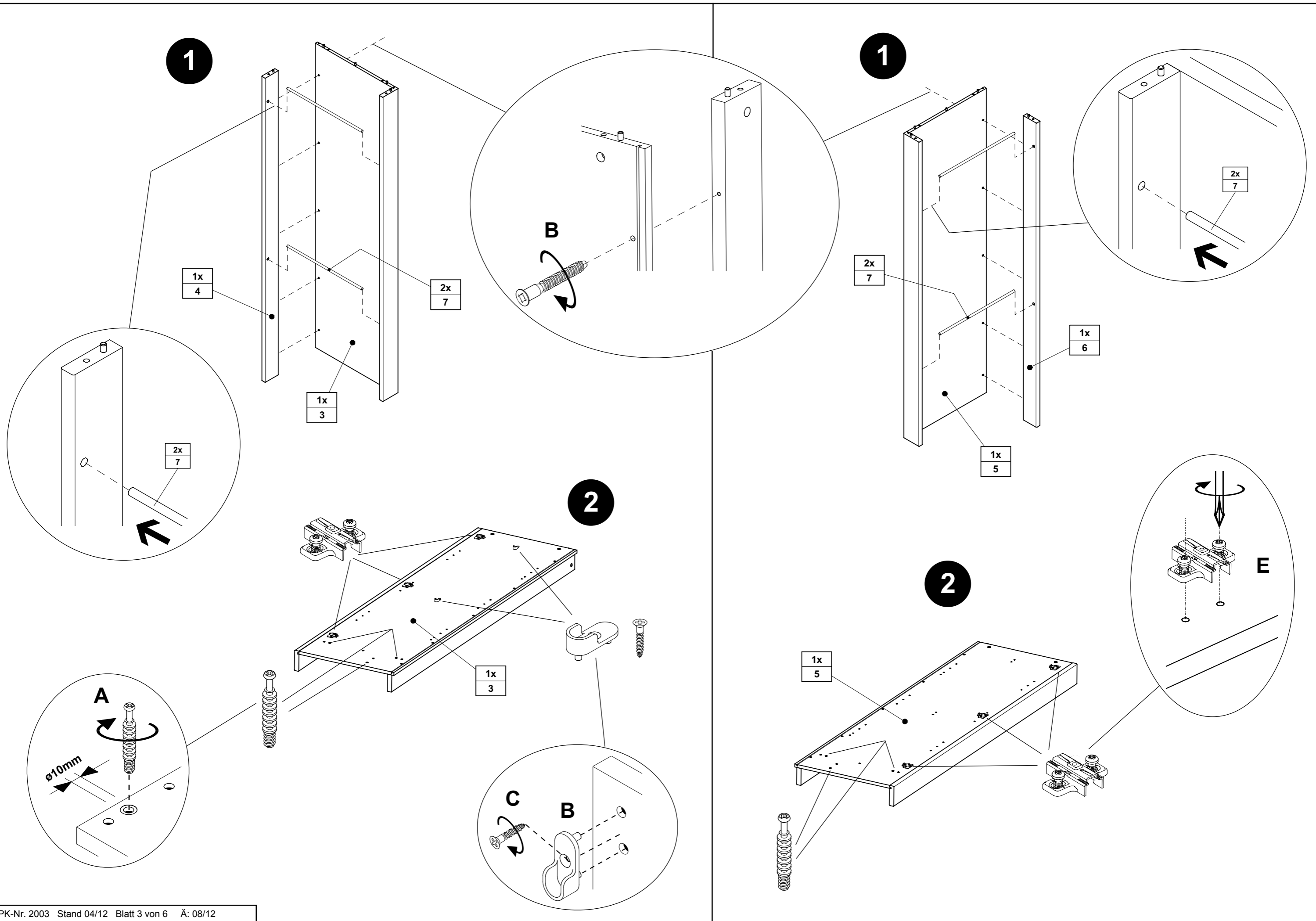

1

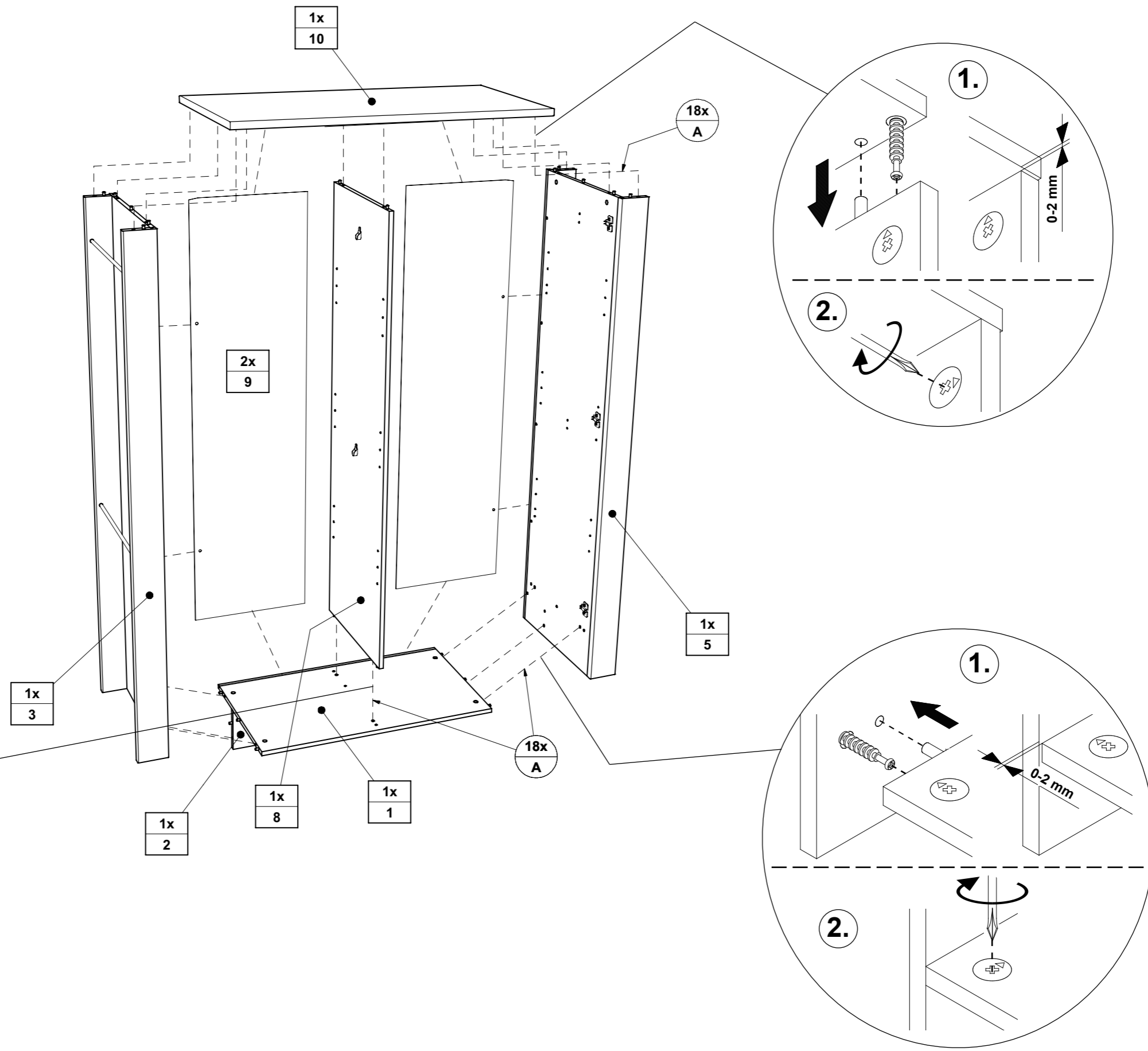

2

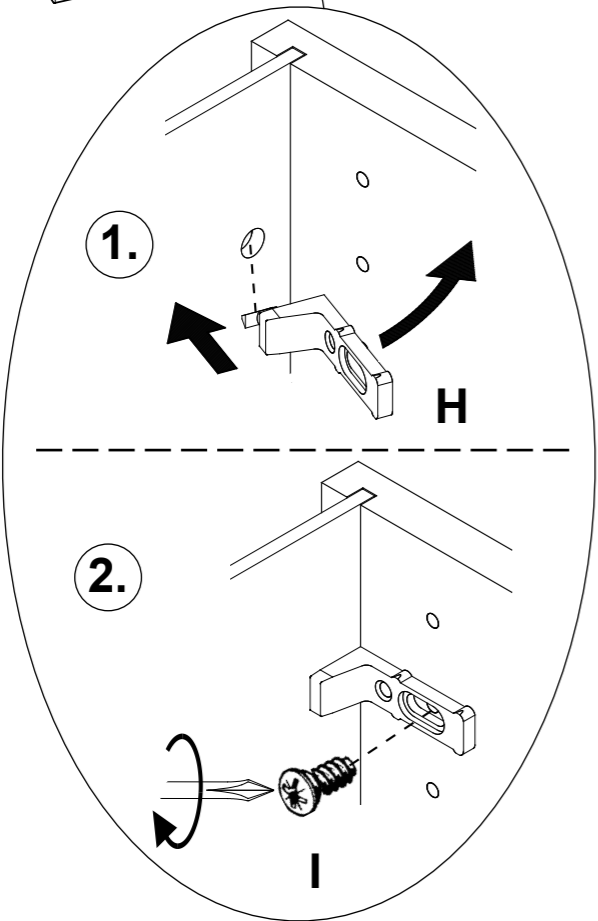
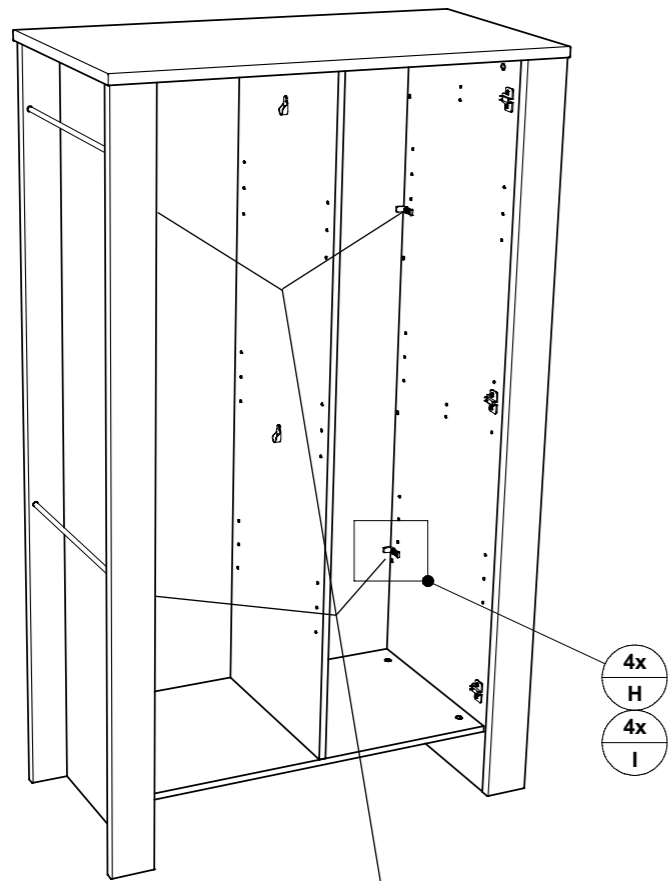

3

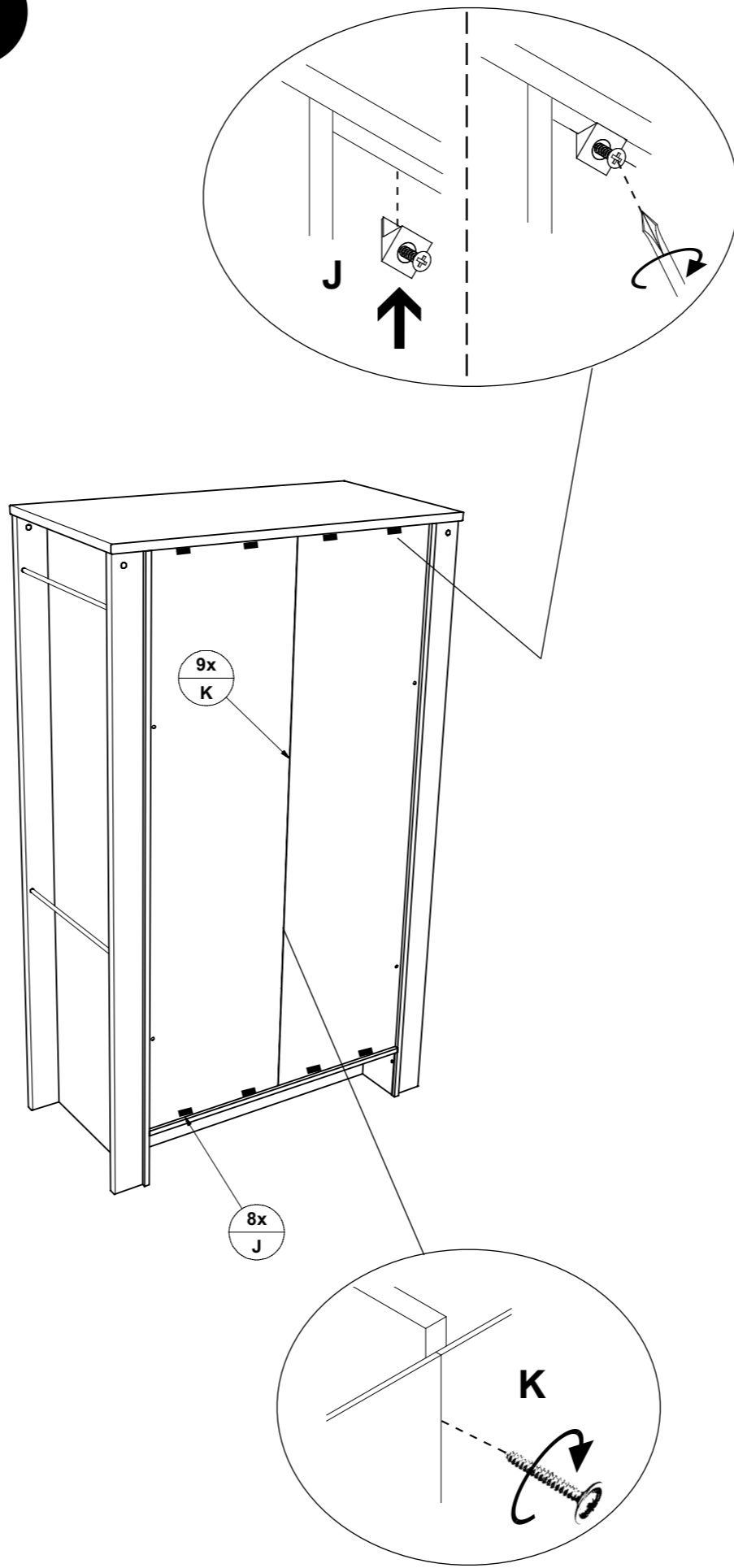

4

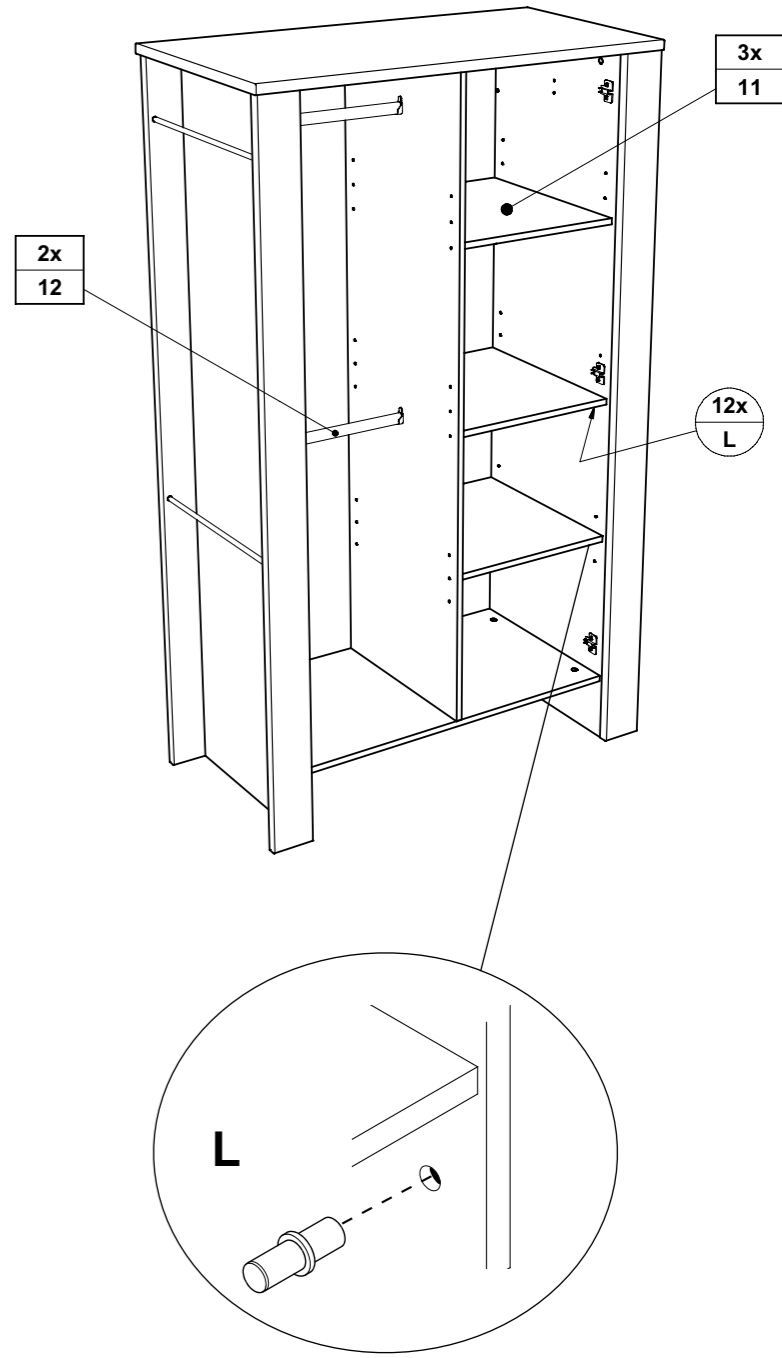

5

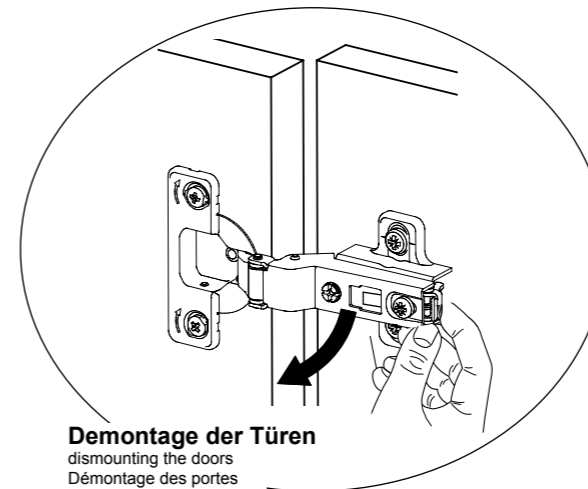
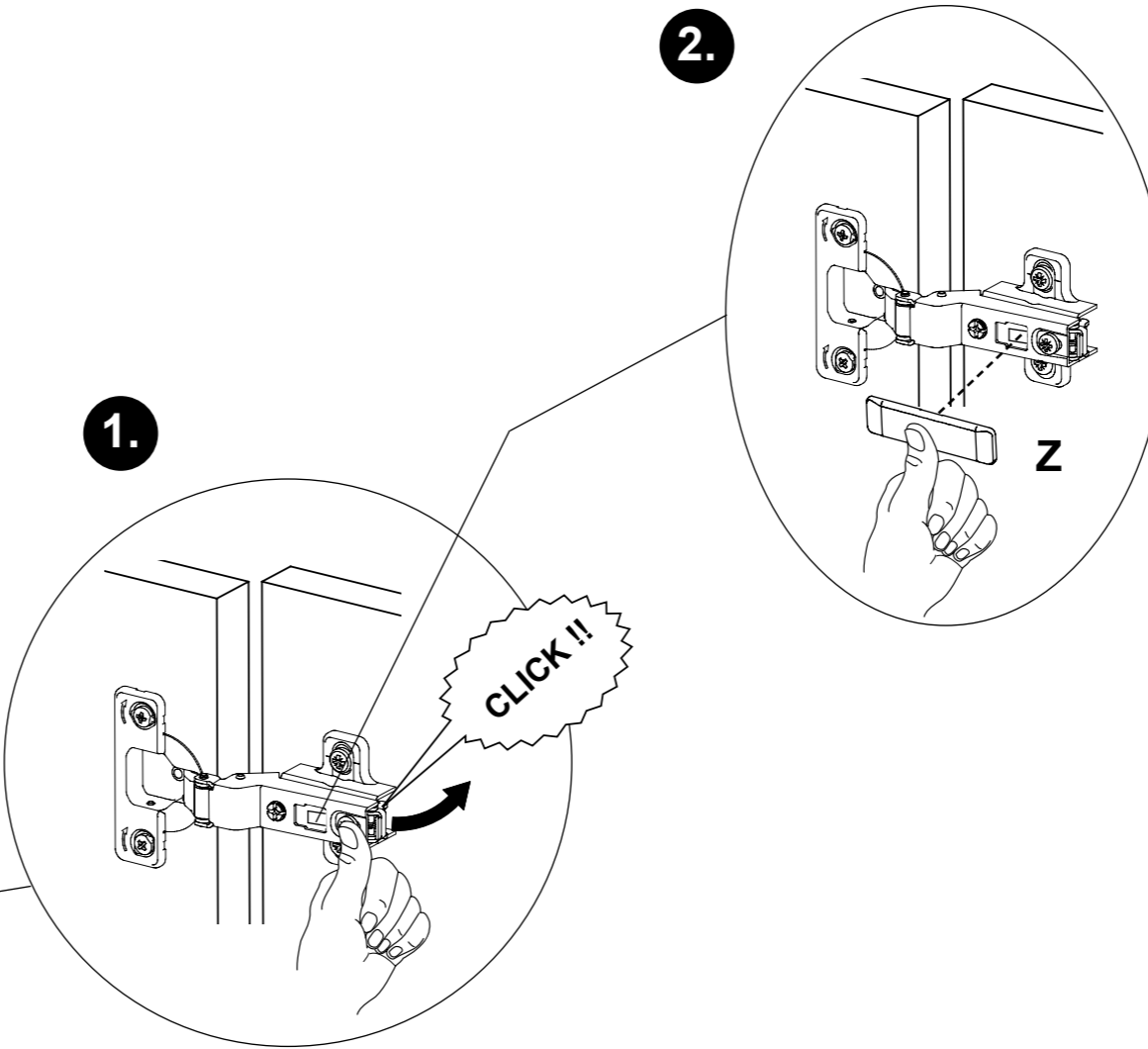
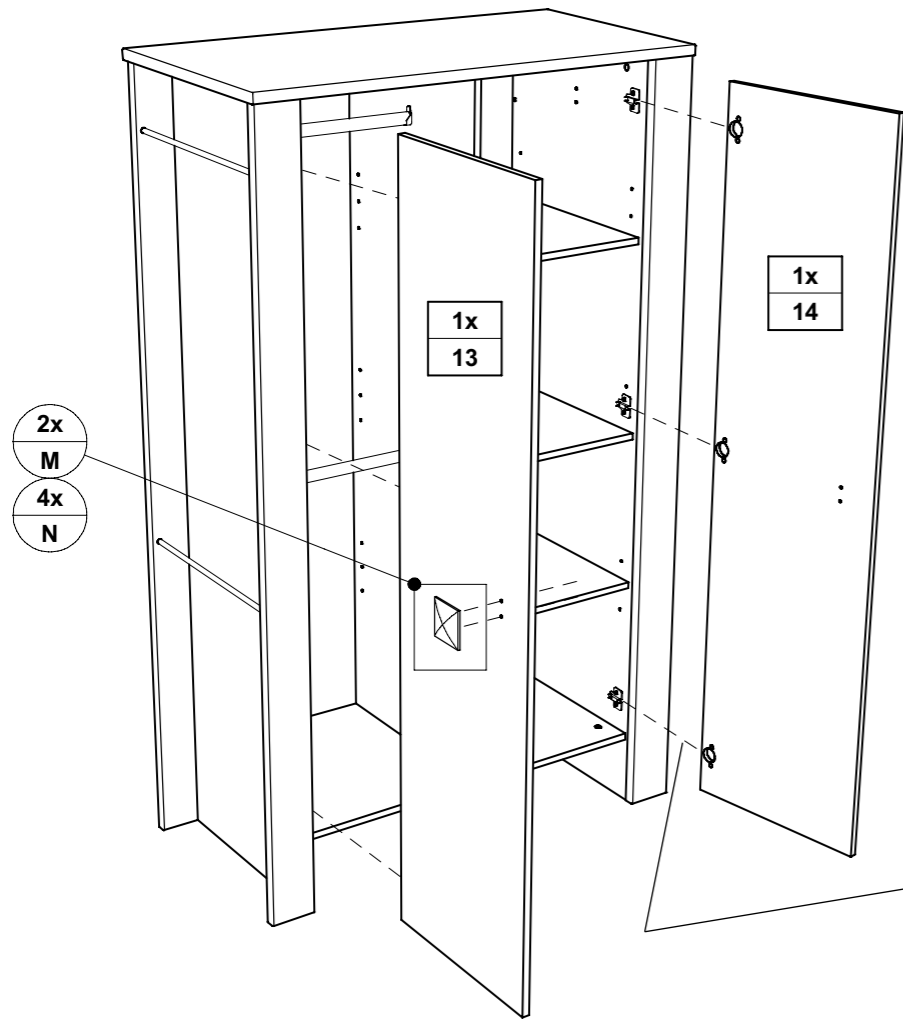

Demontage der Türen

dismounting the doors
Démontage des portes
demontage van de deuren
Desmontaje de las puertas

Justierung der Türen

Adjustement of doors
Ajustement des portes
Uitlijnen van de deuren
Ajuste de las puertas

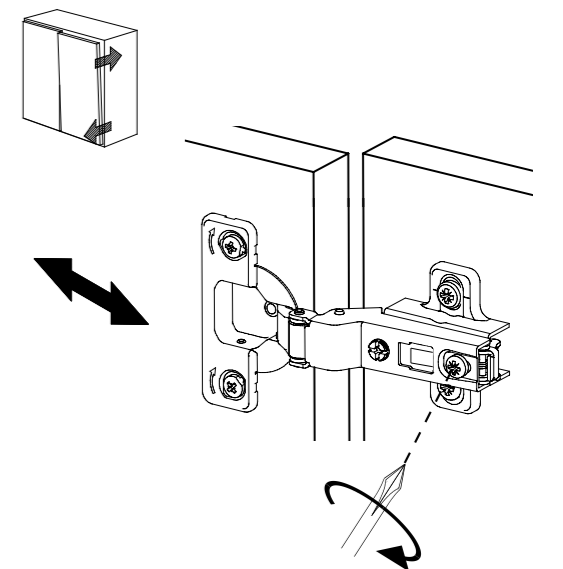
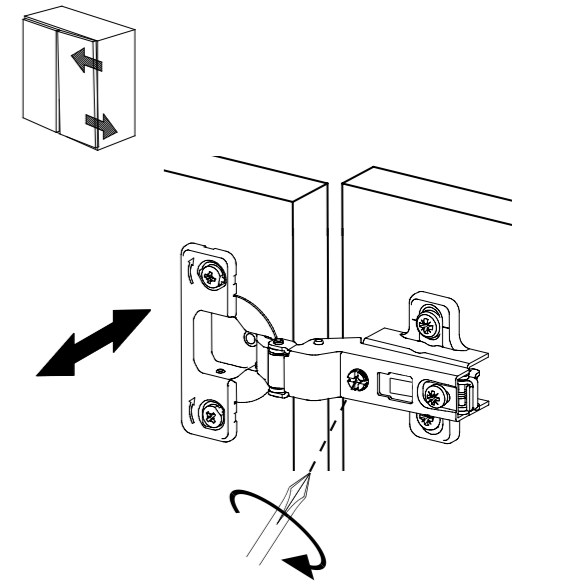
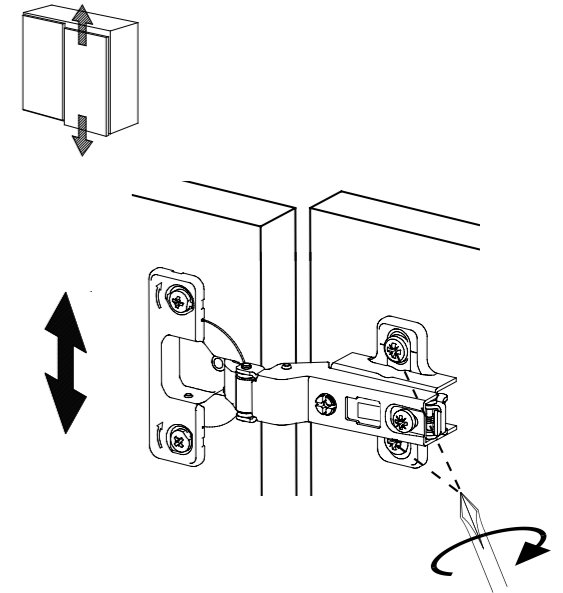

- DE **Pflegehinweis:** Zum Reinigen der Oberflächen ein leicht-feuchtes Tuch oder ein handelsübliches Möbelpflegemittel verwenden.
- FR **Indication sur l'entretien :** pour nettoyer les surfaces, utiliser un chiffon légèrement humide ou un nettoyant pour meubles en vente dans le commerce
- GB **Caring for the...** : In order to clean the surfaces please use a slightly damp cloth or commercially available furniture care product.
- NL **Verzorgingsanwijzing:** Voor het reinigen van de oppervlakken een licht vochtig doek of een gebruikelijk meubelschoonmaakmiddel gebruiken.
- ES **Recomendaciones de cuidado:** Para limpiar las superficies del mueble debe usar un trapo humedecido o un producto de limpieza de muebles comercial.
- GR **Οδηγίες περιποίησης:** Για το καθαρίσμα των επιφανειών να χρησιμοποιείτε ένα ελαφρά νοτισμένο πανάκι ή λούστρο επίπλων.
- IT **Indicazione per pulizia e cura:** Per la pulizia delle superfici utilizzate un panno leggermente umido o un normale prodotto per la cura dei mobili.
- CZ **Pokyny k čištění:** Na čištění povrchu použijte pouze navlhčený kousek látky nebo běžný prostředek na ošetřování nábytku.
- SK **Pokyn k ošetrovaniu:** Na čistenie povrchu používajte mierne navlhčenú handru alebo bežný čistiaci prostriedok na nábytok.
- SI **Navodilo za nego:** Za čiščenje površin uporabljajte malo vlažno sunjo ali trgovsko običajno sredstvo za nego pohištva.
- DK **Pleje:** Rens overflader med en fugtig klud eller et gængs møbelplejemiddel.
- SE **Skötselråd:** Rengör ytorna med en fuktig trasa eller med ett vanligt möbelrengöringsmedel som finns i handeln.
- FI **Hoito-ohje:** Käytä pintojen puhdistukseen kosteata pyyhettä tai yleisen kauppalaadun mukaista huonekalujen hoito-ainetta.
- PL **Wskazówka pielęgnacyjna:** do czyszczenia powierzchni stosować lekko wilgotną ściereczkę lub zwykły środek do pielęgnacji mebli.
- HU **Ápolási útmutatás:** A felületek tisztításához egy enyhén nedves kendőt, vagy kereskedelemben kapható, szokványos bútoralpoló szert használjon.
- RO **Indicații de întreținere:** pentru curățirea suprafețelor folosiți o cârpă umezită ușor sau un produs comercial obișnuit pentru îngrijirea mobilei.
- BG **Указание за поддържане:** Използвайте леко навлажнена кърпа или обикновен препарат за поддържане на мебели, за да почистите повърхностите.
- HR **Upute za njegu:** Za čišćenje površina upotrijebiti jednu lako navlaženu krpu i trgovačko uobičajeno sredstvo za njegu namještaja.
- LT **Rekomendacija priežiūrai:** Paviršius valykite drėgna pašluoste arba parduotuviše įsigyтомis baldų priežiūros priemonėmis.
- RU **Рекомендации по уходу:** для очистки поверхностей используйте слегка влажную тряпку или обычное средство по уходу за мебелью.
- CN **保养说明:** 清洁表面只需用稍微潮湿的布或普通的家具清洁剂即可。