

Gebrauchsanleitung / Instructions / Mode demloi / Gebruiksaanwijzing / Instrucciones

PAIDI
Möbel GmbH
D-97840 Hafenlohr/Main

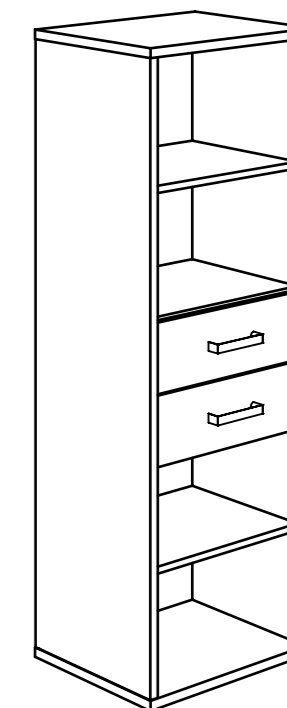

125 6432
125 6111
125 6154
125 6141



1:1
DIN A3

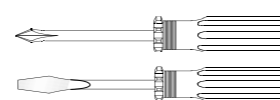
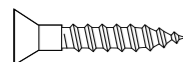
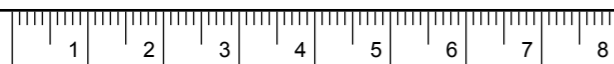

ca. 0,5h



A	B	C	D
8x 681 0759	12x 681 8126	Gleiter 4x 681 1011	8x 681 2498

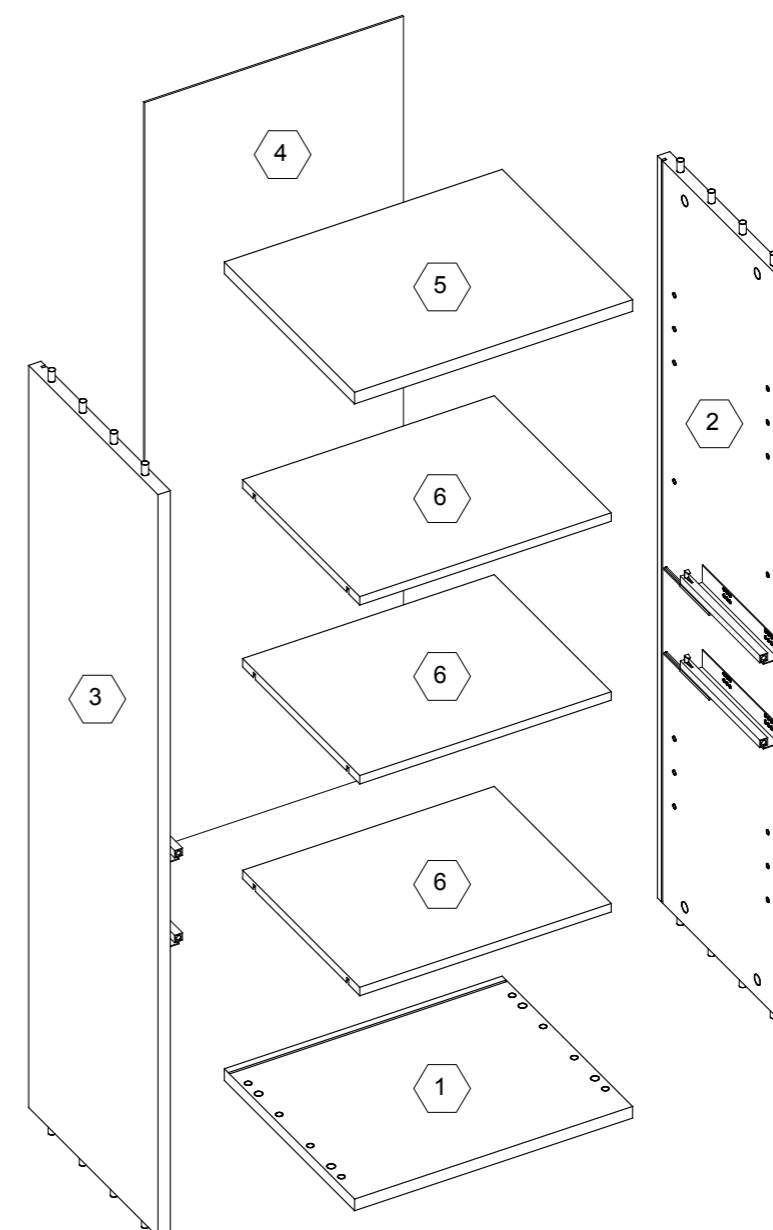
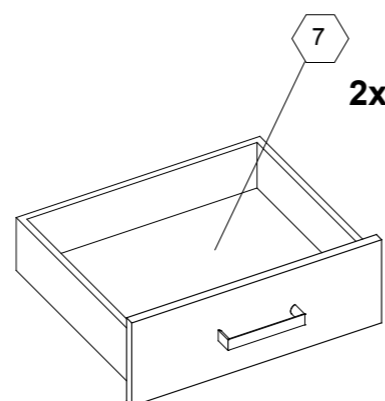

- DE Pflegehinweis:** Zum Reinigen der Oberflächen ein leicht-feuchtes Tuch oder ein handelsübliches Möbelpflegemittel verwenden.
- FR Indication sur l'entretien :** pour nettoyer les surfaces, utiliser un chiffon légèrement humide ou un nettoyeur pour meubles en vente dans le commerce
- GB Caring for the... :** In order to clean the surfaces please use a slightly damp cloth or commercially available furniture care product.
- NL Verzorgingsanwijzing:** Voor het reinigen van de oppervlakken een licht vochtig doek of een gebruikelijk meubelschoonmaakmiddel gebruiken.
- ES Recomendaciones de cuidado:** Para limpiar las superficies del mueble debe usar un trapo humedecido o un producto de limpieza de muebles comercial.
- GR Οδηγίες περιποίησης:** Για το καθάρισμα των επιφανειών να χρησιμοποιείτε ένα ελαφρά νοτισμένο πανάκι ή λούστρο επίπλων.
- IT Indicazione per pulizia e cura:** Per la pulizia delle superfici utilizzate un panno leggermente umido o un normale prodotto per la cura dei mobili.
- CZ Pokyny k čištění:** Na čištění povrchu použijte pouze navlhčený kousek látky nebo běžný prostředek na ošetřování nábytku.
- SK Pokyn k ošetrovaniu:** Na čistenie povrchu používajte mierne navlhčenú handru alebo bežný čistiaci prostriedok na nábytok.
- SI Navodilo za nego:** Za čiščenje površin uporabljajte malo vlažno čunjo ali trgovsko običajno sredstvo za nego pohištva.
- DK Pleje:** Rens overflader med en fugtig klud eller et gængs møbelplejemiddel.
- SE Skötselråd:** Rengör ytorna med en fuktig trasa eller med ett vanligt möbelrengöringsmedel som finns i handeln.
- FI Hoito-ohje:** Käytä pintojen puhdistukseen kosteata pyyhettä tai yleisen kauppalaadun mukaista huonekalujen hoito-ainetta.
- PL Wskazówka pielęgnacyjna:** do czyszczenia powierzchni stosować lekko wilgotną ściereczkę lub zwykły środek do pielęgnacji mebli.
- HU Ápolási útmutatás:** A felületek tisztításához egy enyhén nedves kendőt, vagy kereskedelemben kapható, szokványos bútorpótló szert használjon.
- RO Indicații de întreținere:** pentru curățirea suprafețelor folosiți o cârpă umezită ușor sau un produs comercial obișnuit pentru îngrijirea mobilei.
- BG Указание за поддържане:** Използвайте леко навлажнена кърпа или обикновен препарат за поддържане на мебели, за да почистите повърхностите.
- HR Upute za njegu:** Za čišćenje površina upotrijebite jednu lako navlaženu krpu i trgovačko uobičajeno sredstvo za njegu namještaja.
- LT Rekomendacija priežiūrai:** Paviršius valykite drėgna pašluoste arba parduotuvišė įsigytomis baldų priežiūros priemonėmis.

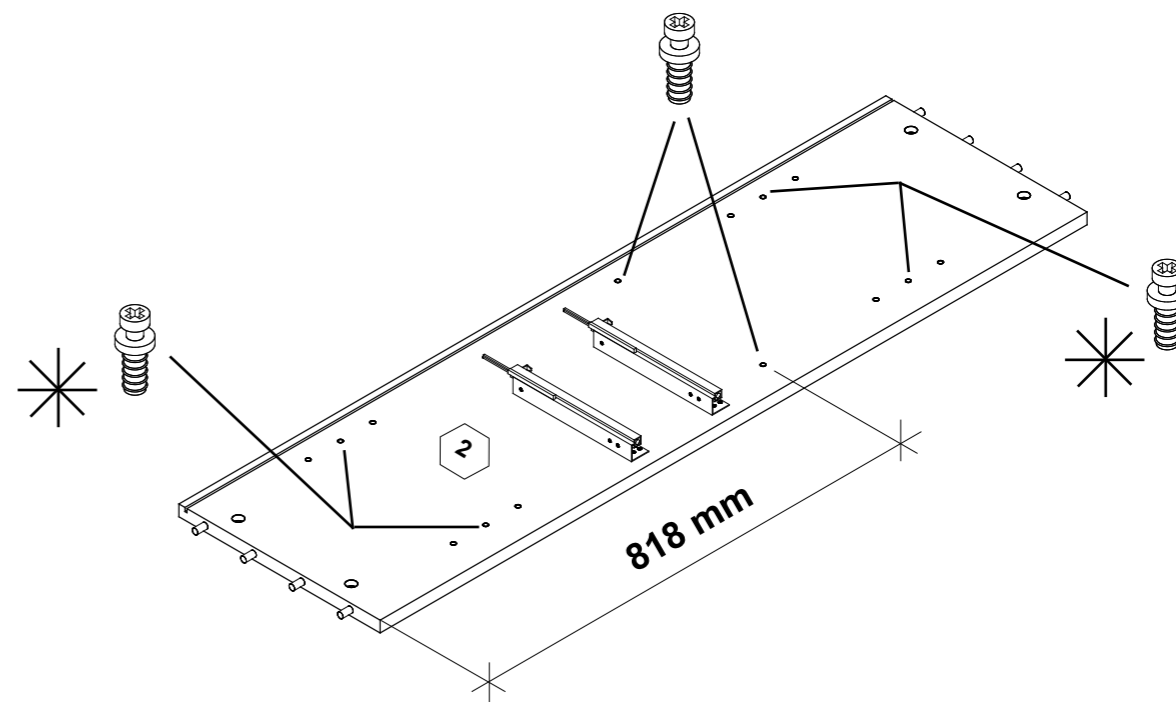
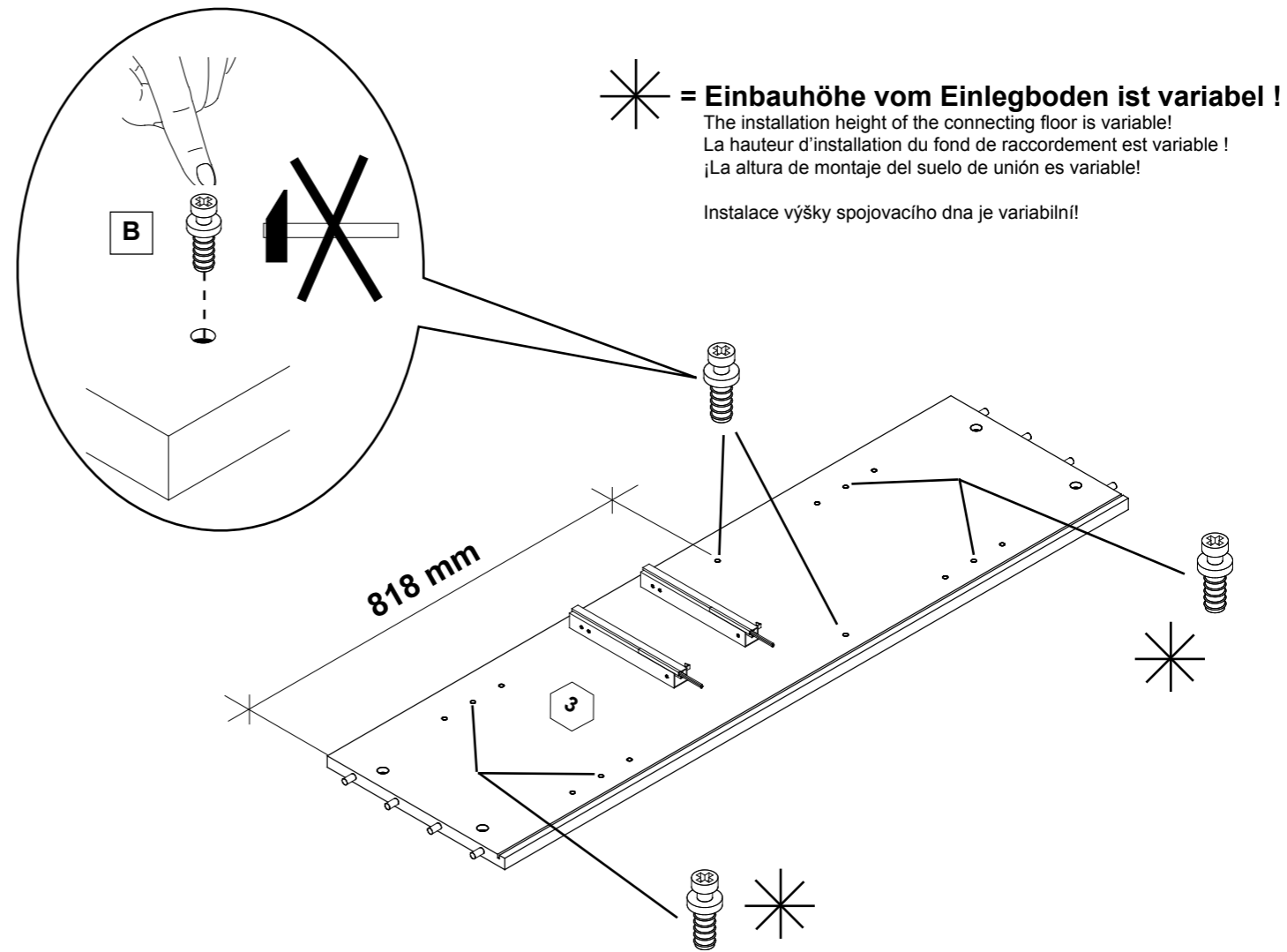
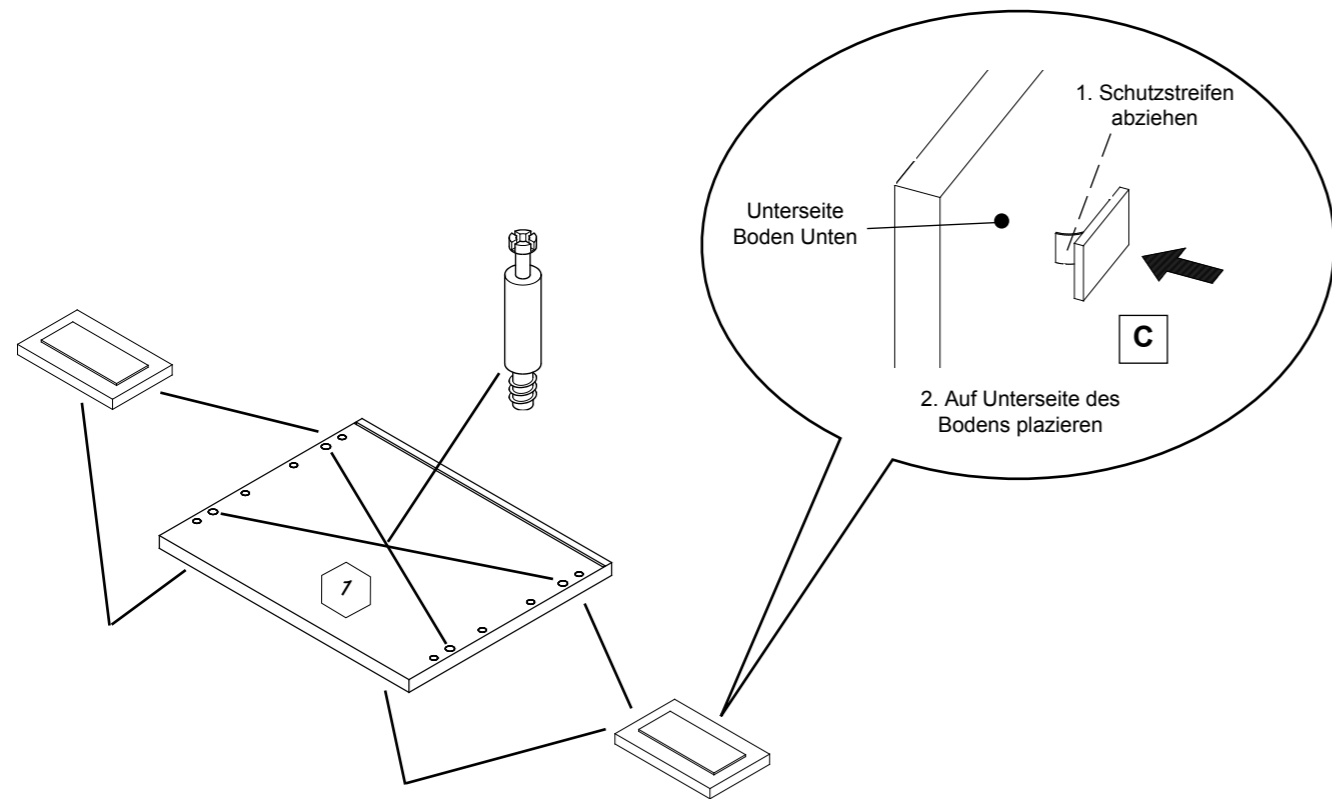
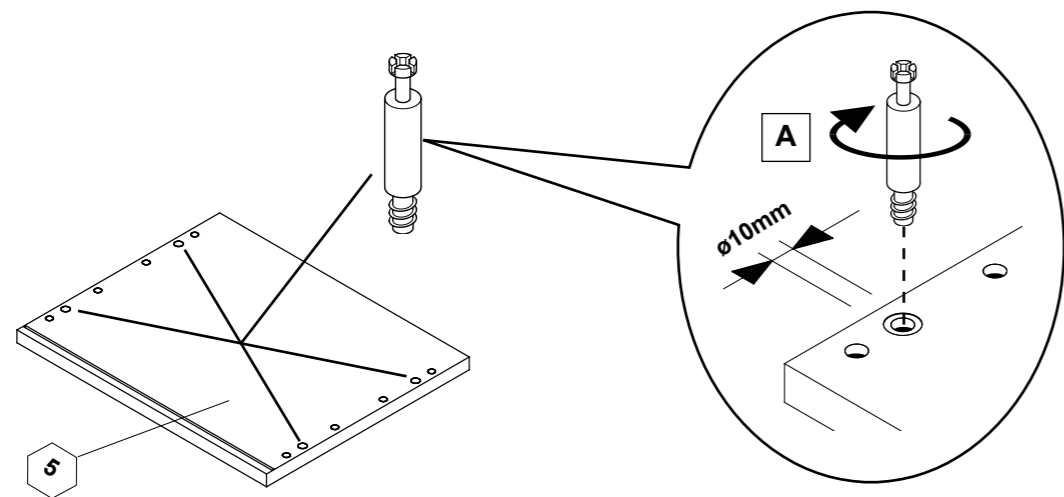

1

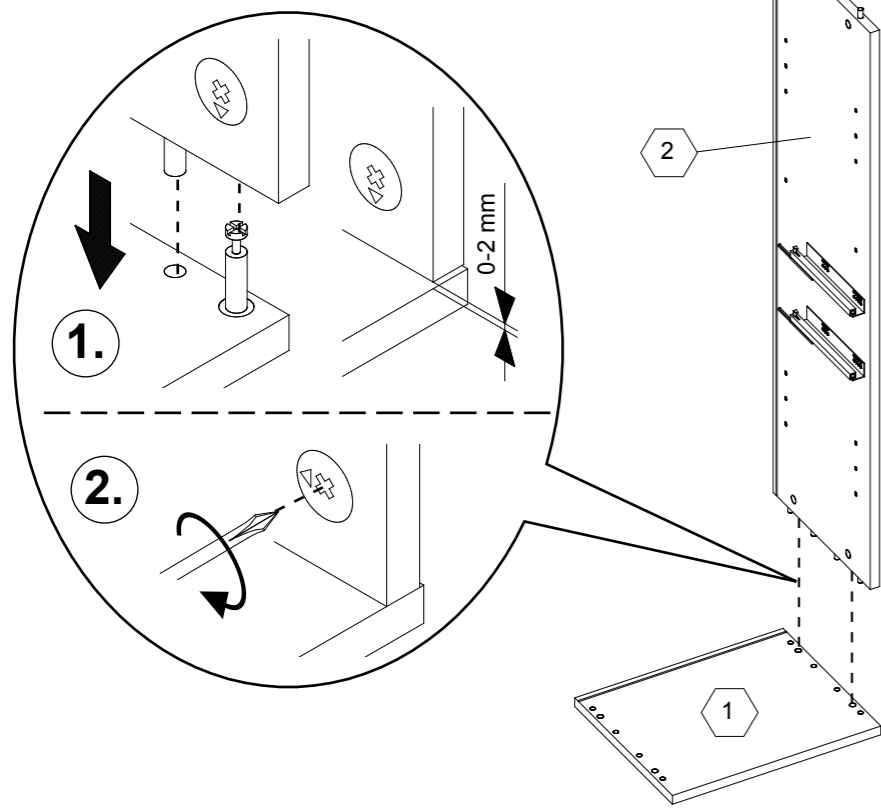

2

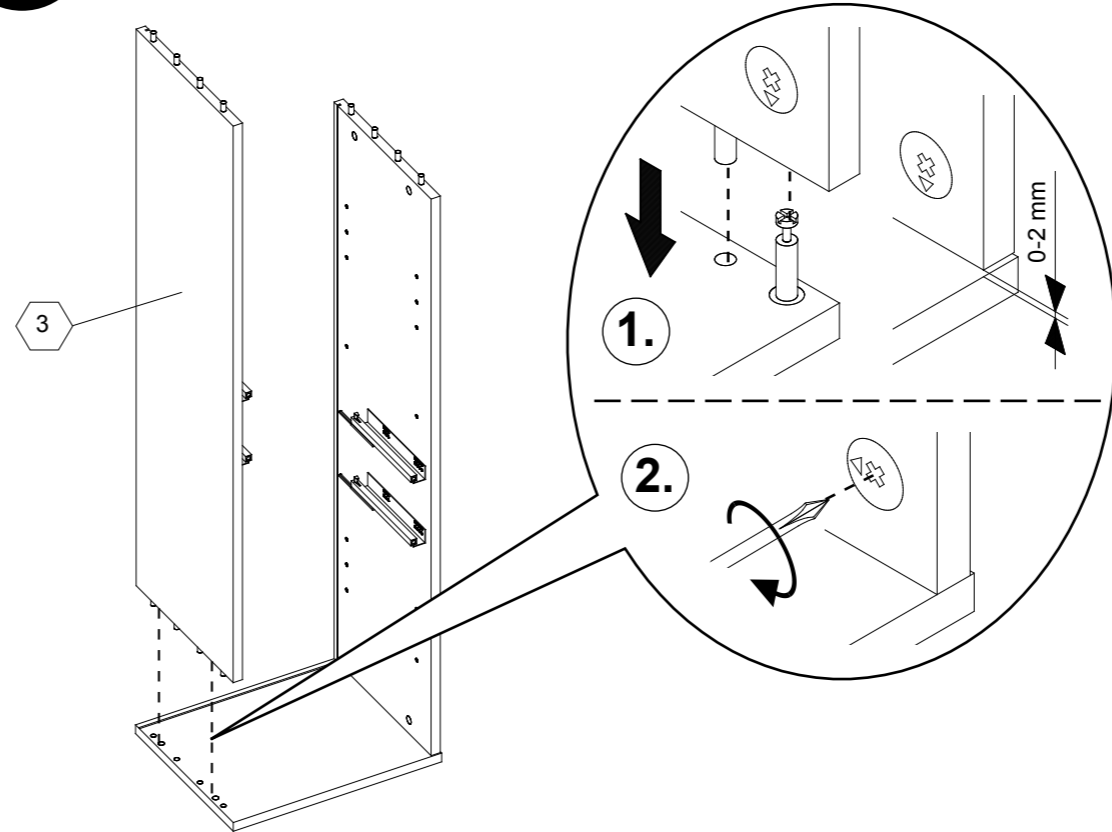

3

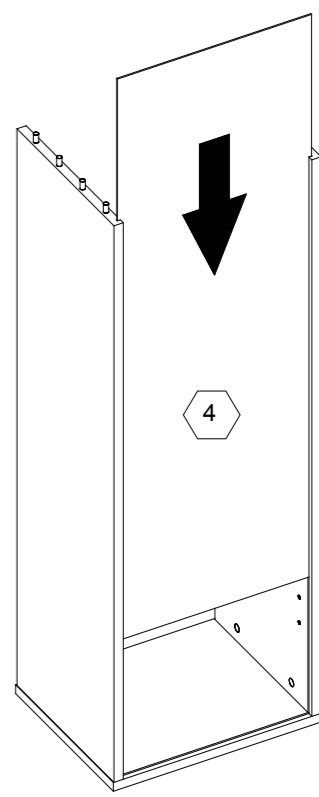

4

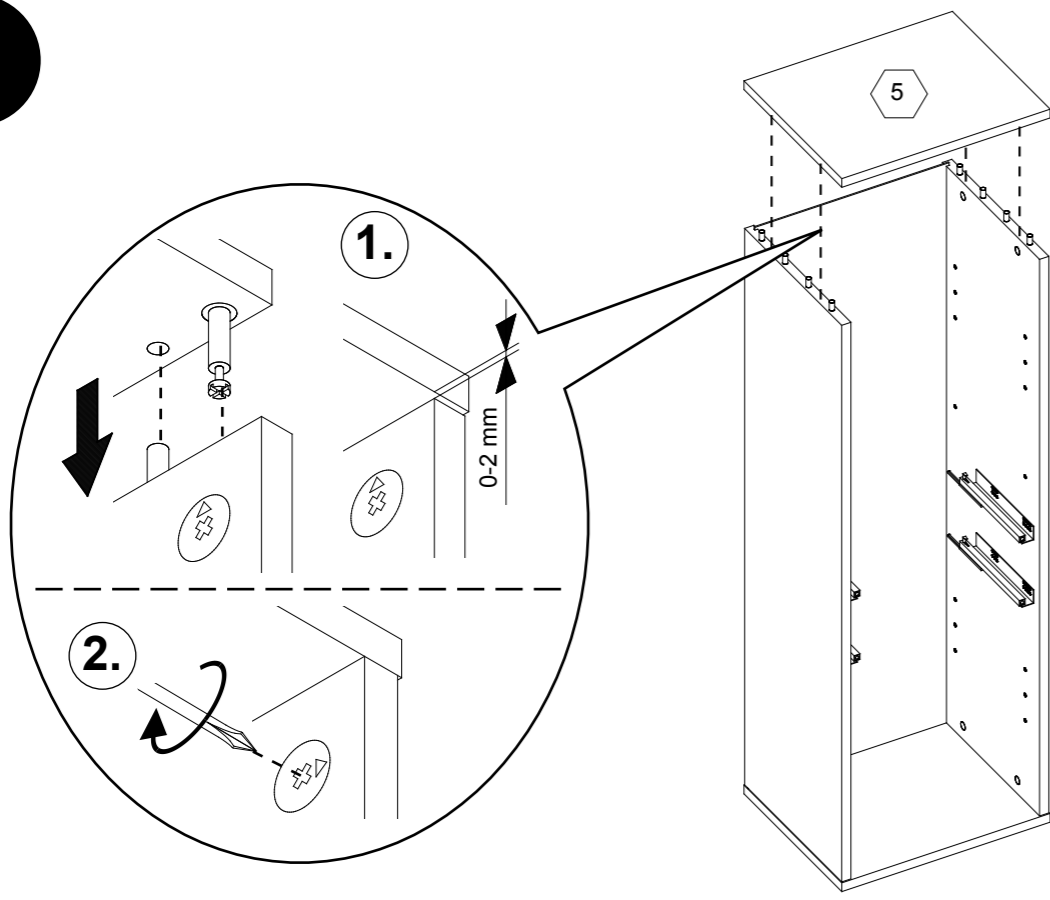

5

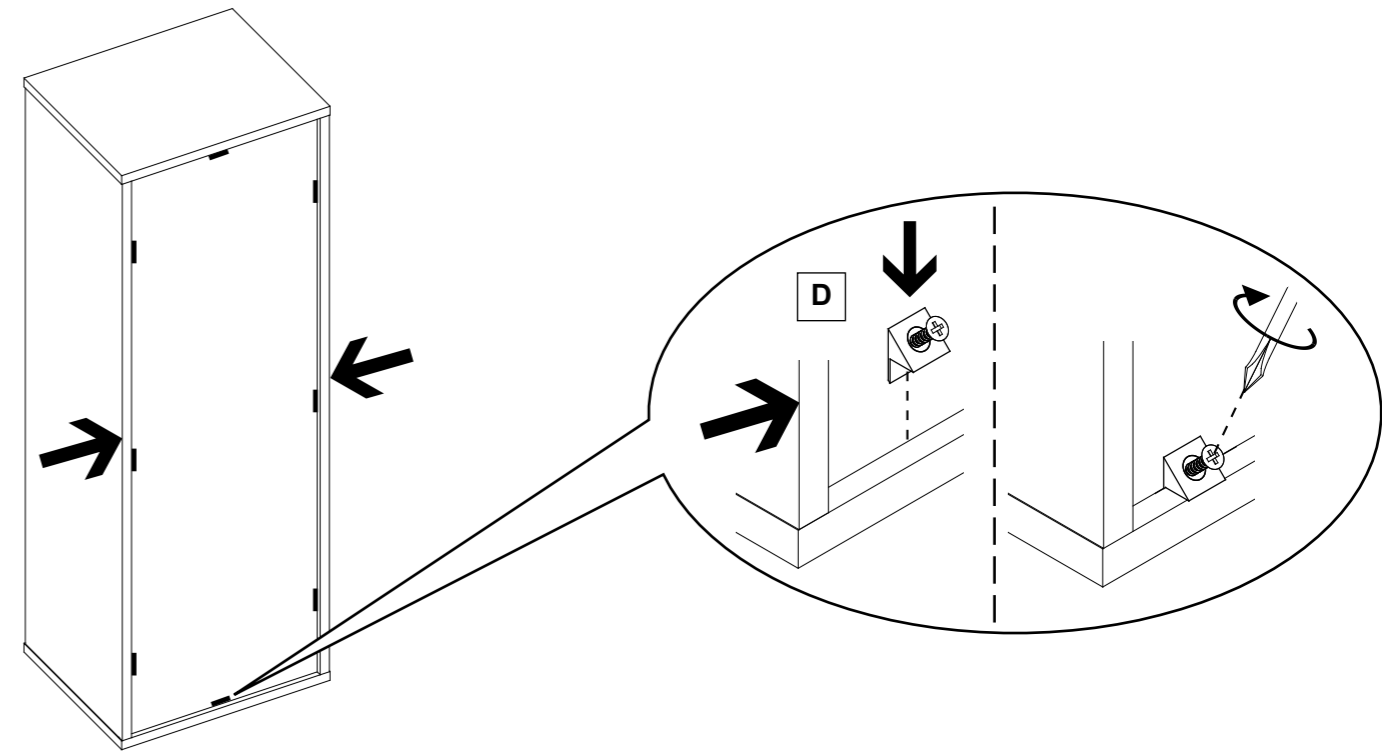

6

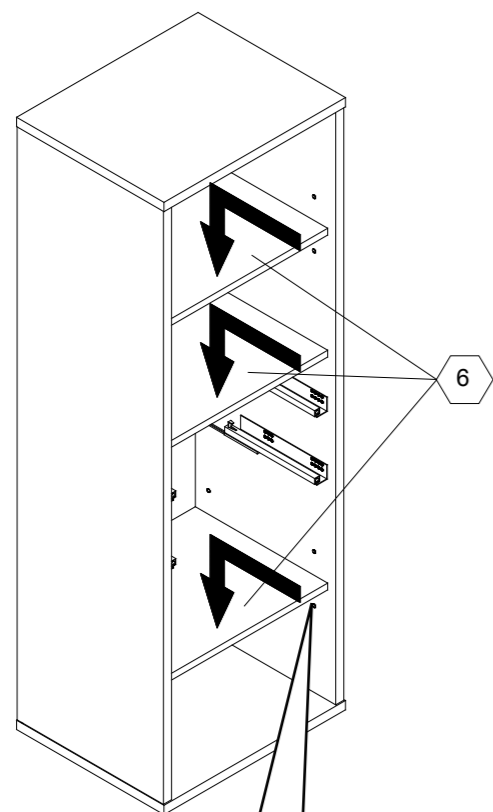

7

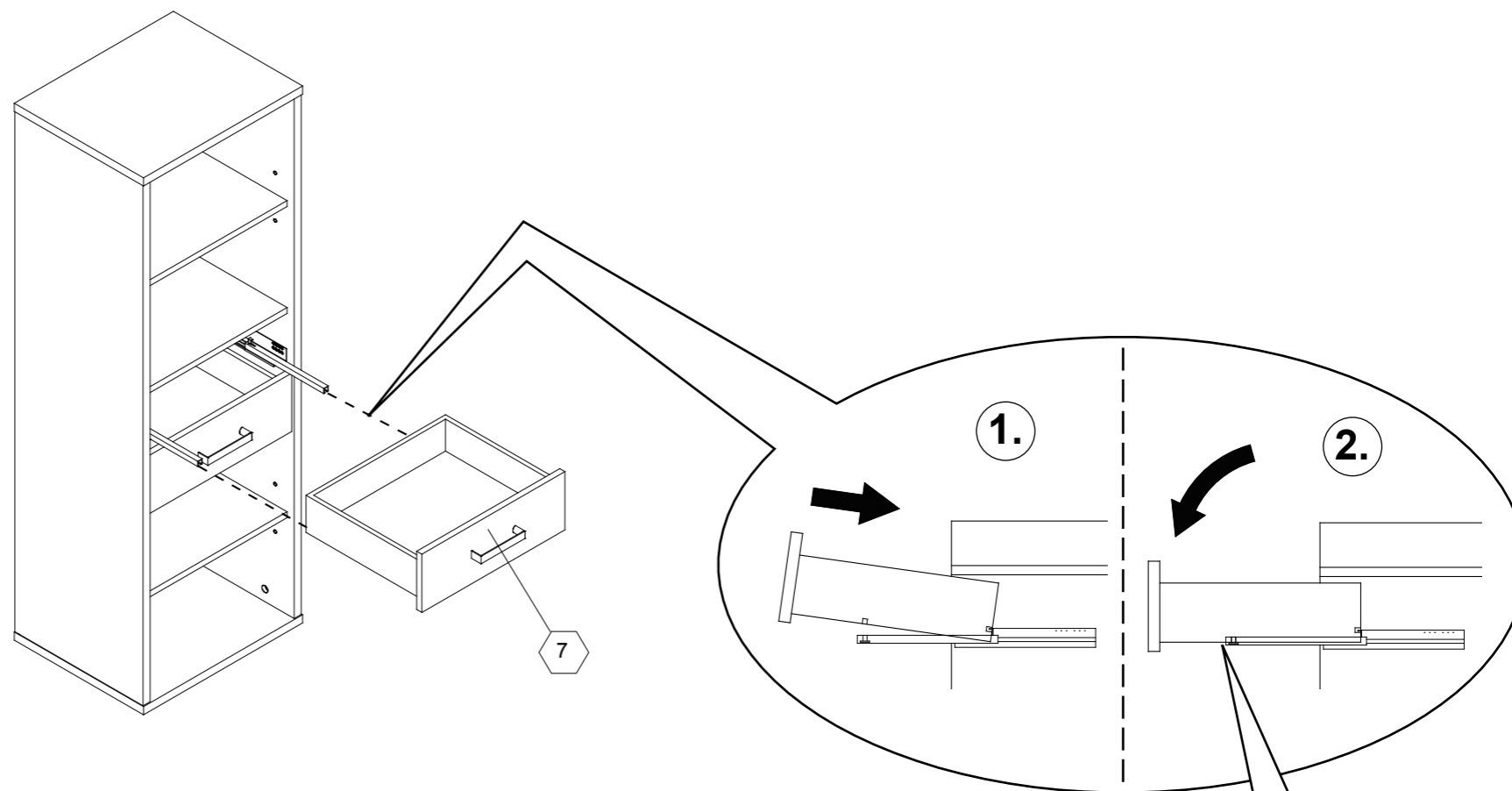

Justierung der Schubkästen

Adjustement of drawers
 Ajustement des tiroirs
 Uitlijnen van de laden
 Ajuste de las cajones

