

# Gebrauchsanleitung / Instructions / Mode d'emploi / Gebruiksaanwijzing / Instrucciones

PAIDI  
Möbel GmbH  
Hauptstraße 87  
D-97840 Hafenhöhr/Main

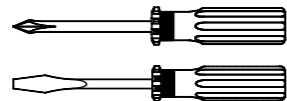

1:1  
DIN A3

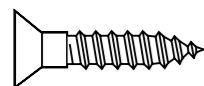
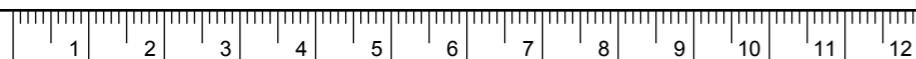

ca. 0,5h



138 6126

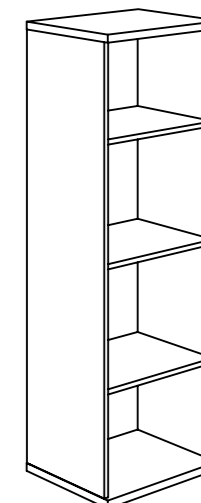

138 6126

138 6226

A	B	C	D
8x 681 0759	12x 681 8126	4x 681 1011	8x 681 2498

A	B	C	D
8x 681 0759	20x 681 8126	4x 681 1011	10x 681 2498

## Wandbefestigung

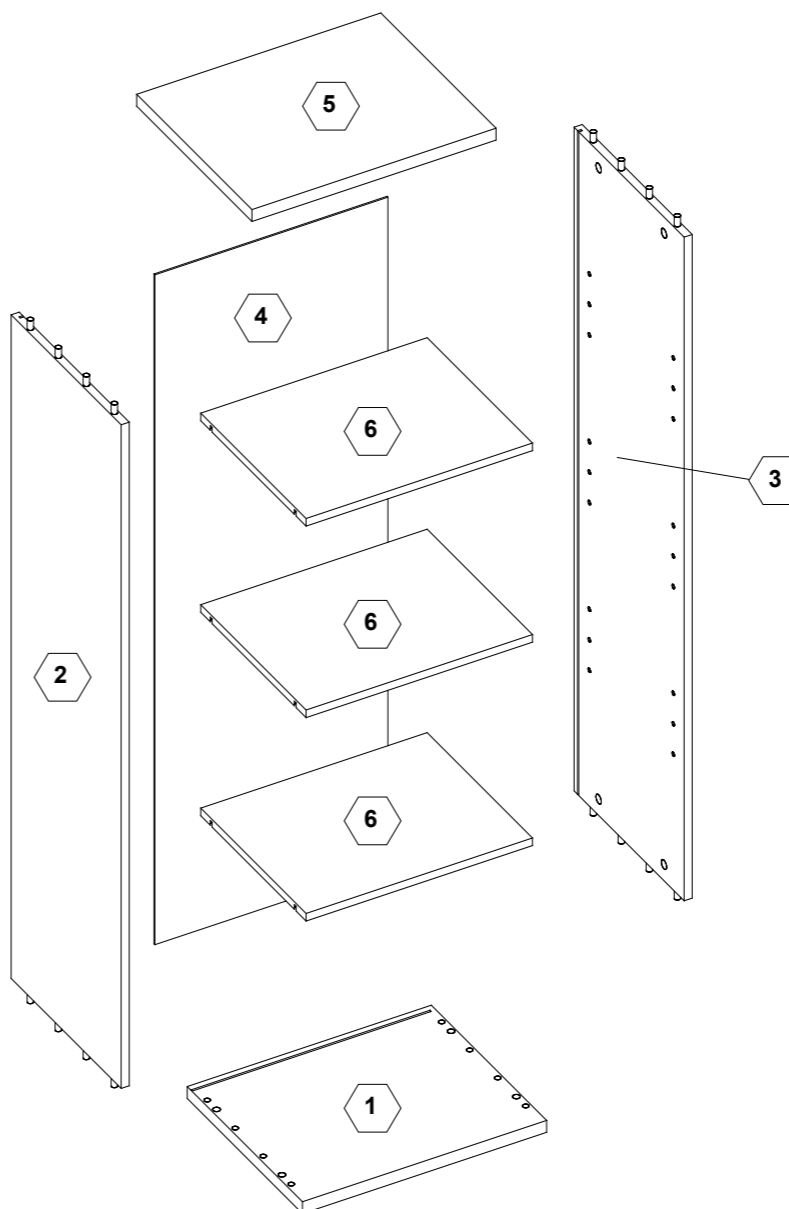
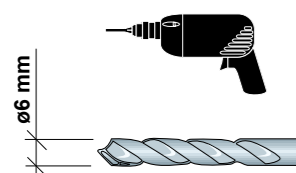
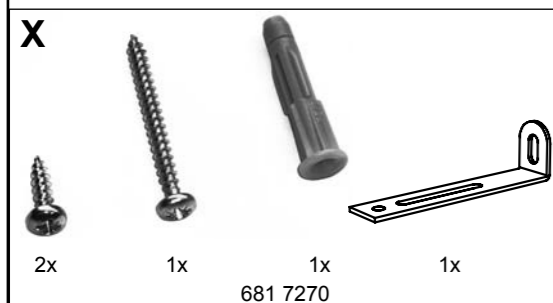

138 6226

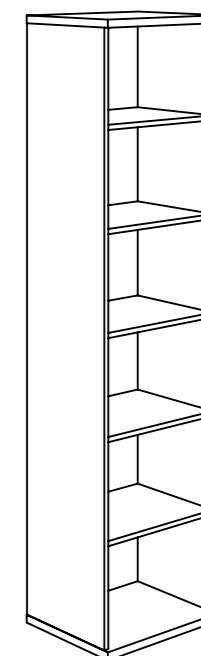

- DE Pflegehinweis:** Zum Reinigen der Oberflächen ein leicht-feuchtes Tuch oder ein handelsübliches Möbelpflegemittel verwenden.
- FR Indication sur l'entretien :** pour nettoyer les surfaces, utiliser un chiffon légèrement humide ou un nettoyeur pour meubles en vente dans le commerce
- GB Caring for the... :** In order to clean the surfaces please use a slightly damp cloth or commercially available furniture care product.
- NL Verzorgingsaanwijzing:** Voor het reinigen van de oppervlakken een licht vochtig doek of een gebruikelijk meubelschoonmaakmiddel gebruiken.
- ES Recomendaciones de cuidado:** Para limpiar las superficies del mueble debe usar un trapo humedecido o un producto de limpieza de muebles comercial.
- GR Οδηγίες περιποίησης:** Για το καθάρισμα των επιφανειών να χρησιμοποιείτε ένα ελαφρά νοτισμένο πανάκι ή λούστρο επίπλων.
- IT Indicazione per pulizia e cura:** Per la pulizia delle superfici utilizzate un panno leggermente umido o un normale prodotto per la cura dei mobili.
- CZ Pokyny k čištění:** Na čištění povrchu použijte pouze navlhčený kousek látky nebo běžný prostředek na ošetřování nábytku.
- SK Pokyn k ošetrovaniu:** Na čistenie povrchu používajte mierne navlhčenú handru alebo bežný čistiaci prostriedok na nábytok.
- SI Navodilo za nego:** Za čiščenje površin uporabljajte malo vlažno cunjo ali trgovsko običajno sredstvo za nego pohištva.
- DK Pleje:** Rens overflader med en fugtig klud eller et gængs møbelplejemiddel.
- SE Skötselråd:** Rengör ytorna med en fuktig trasa eller med ett vanligt möbelrengöringsmedel som finns i handeln.
- FI Hoito-ohje:** Käytä pintojen puhdistukseen kosteata pyyhettä tai yleisen kauppalaadun mukaista huonekalujen hoito-ainetta.
- PL Wskazówka pielęgnacyjna:** do czyszczenia powierzchni stosować lekko wilgotną ściereczkę lub zwykły środek do pielęgnacji mebli.
- HU Ápolási útmutatás:** A felületek tisztításához egy enyhén nedves kendőt, vagy kereskedelemben kapható, szokványos bútórápoló szert használjon.
- RO Indicații de întreținere:** pentru curățirea suprafețelor folosiți o cârpă umezită ușor sau un produs comercial obișnuit pentru îngrijirea mobilei.
- BG Указание за поддръжане:** Използвайте леко навлажнена кърпа или обикновен препарат за поддръжане на мебели, за да почистите повърхностите.
- HR Upute za njegu:** Za čišćenje površina upotrijebiti jednu lako navlaženu krpu i trgovačko uobičajeno sredstvo za njegu namještaja.
- LT Rekomendacija priežiūrai:** Paviršius valykite drėgna pašuoste arba parduotuvėse įsigytomis baldų priežiūros priemonėmis.
- RU Рекомендации по уходу:** для очистки поверхностей используйте слегка влажную тряпку или обычное средство по уходу за мебелью.
- CN 保养说明:** 清洁表面只需用稍微潮湿的布或普通的家具清洁剂即可。

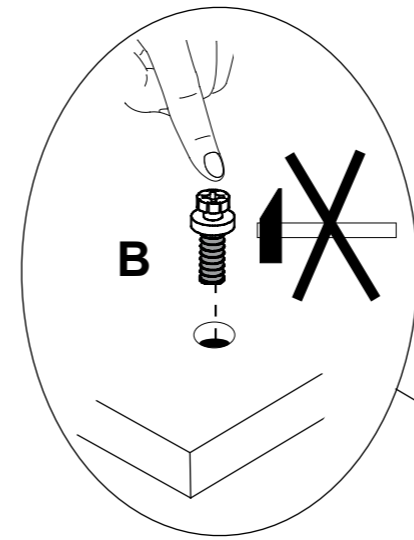
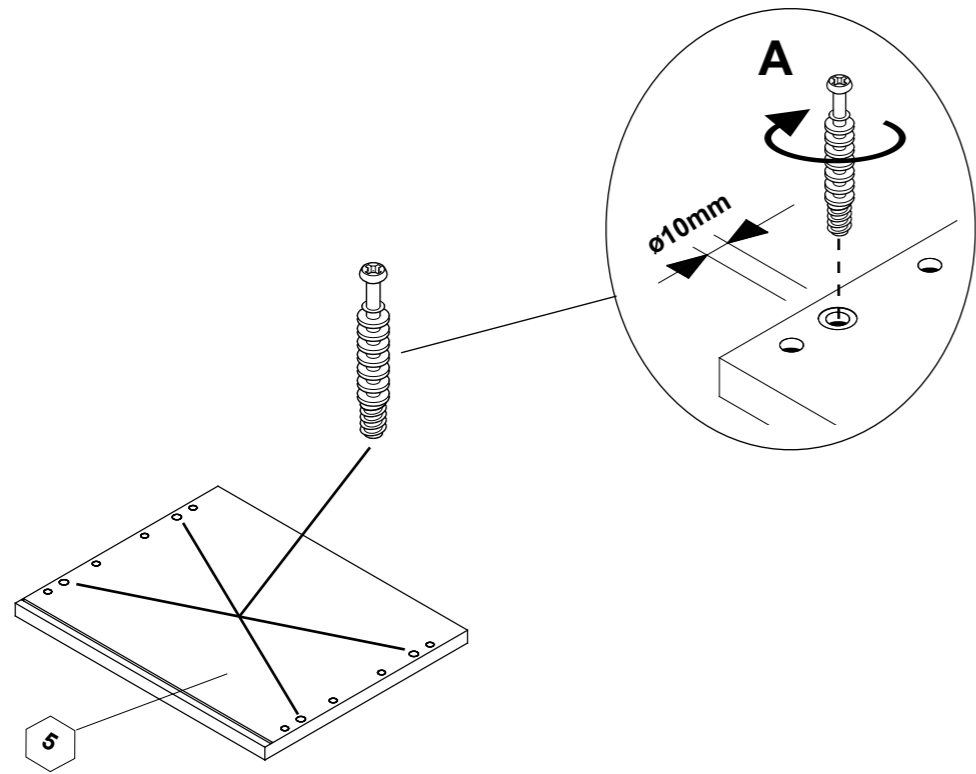

\* = Einbauhöhe vom Einlegboden ist variabel !  
 The installation height of the connecting floor is variable!  
 La hauteur d'installation du fond de raccordement est variable !  
 ¡La altura de montaje del suelo de unión es variable!  
 Instalace výšky spojovacího dna je variabilní!

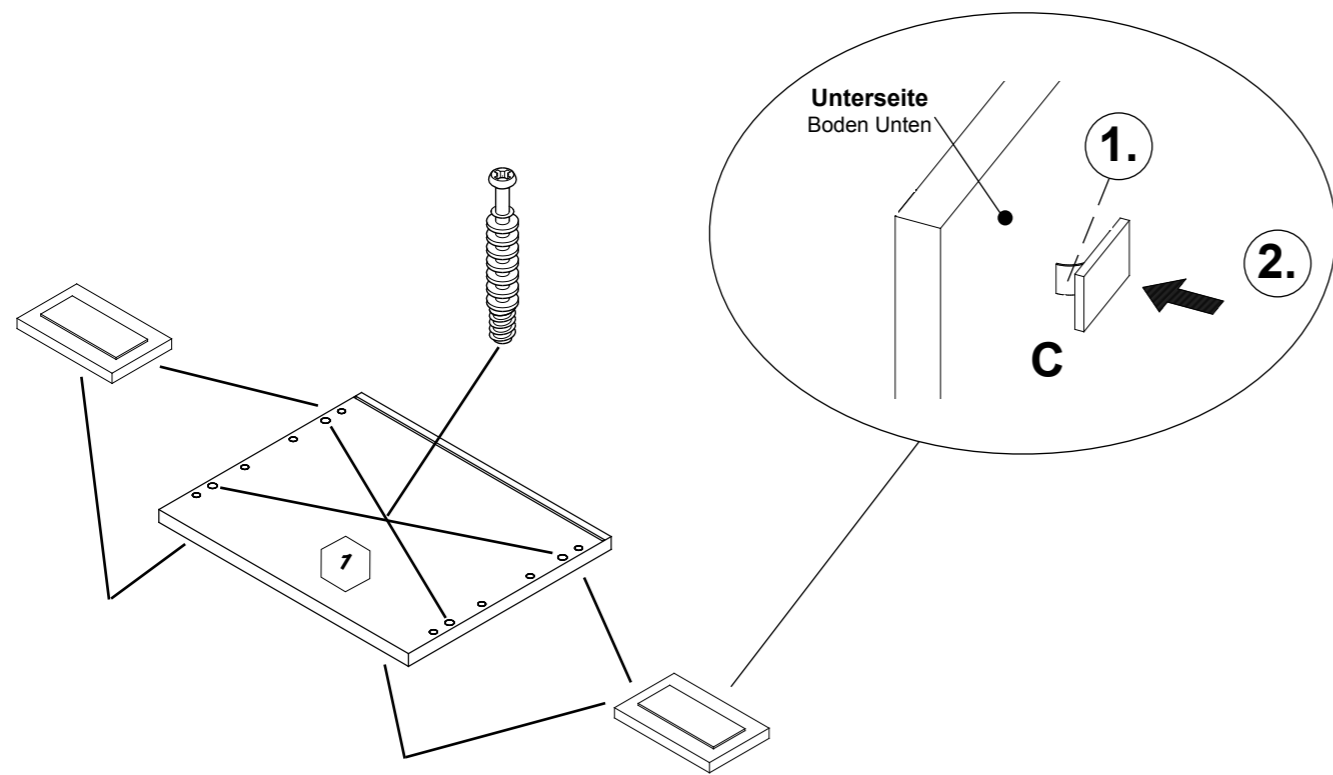
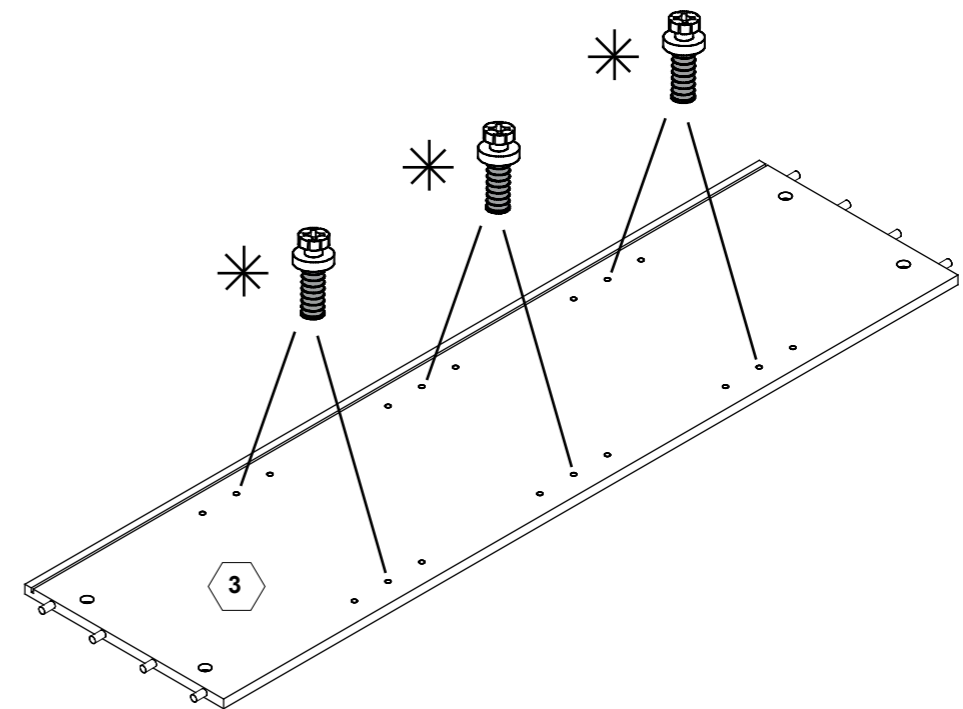
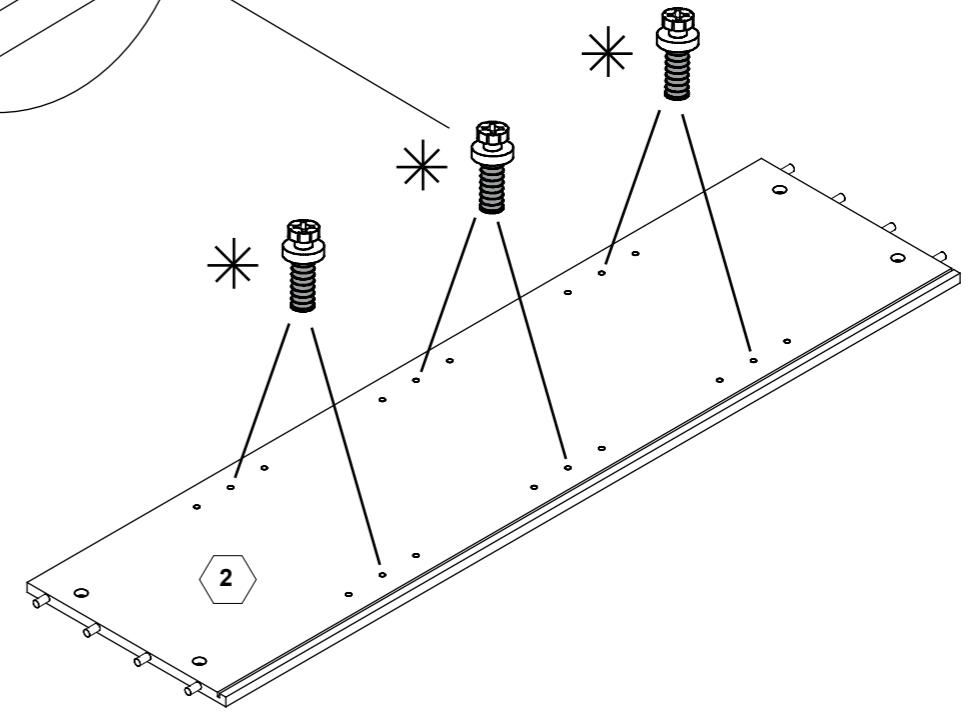

**1**

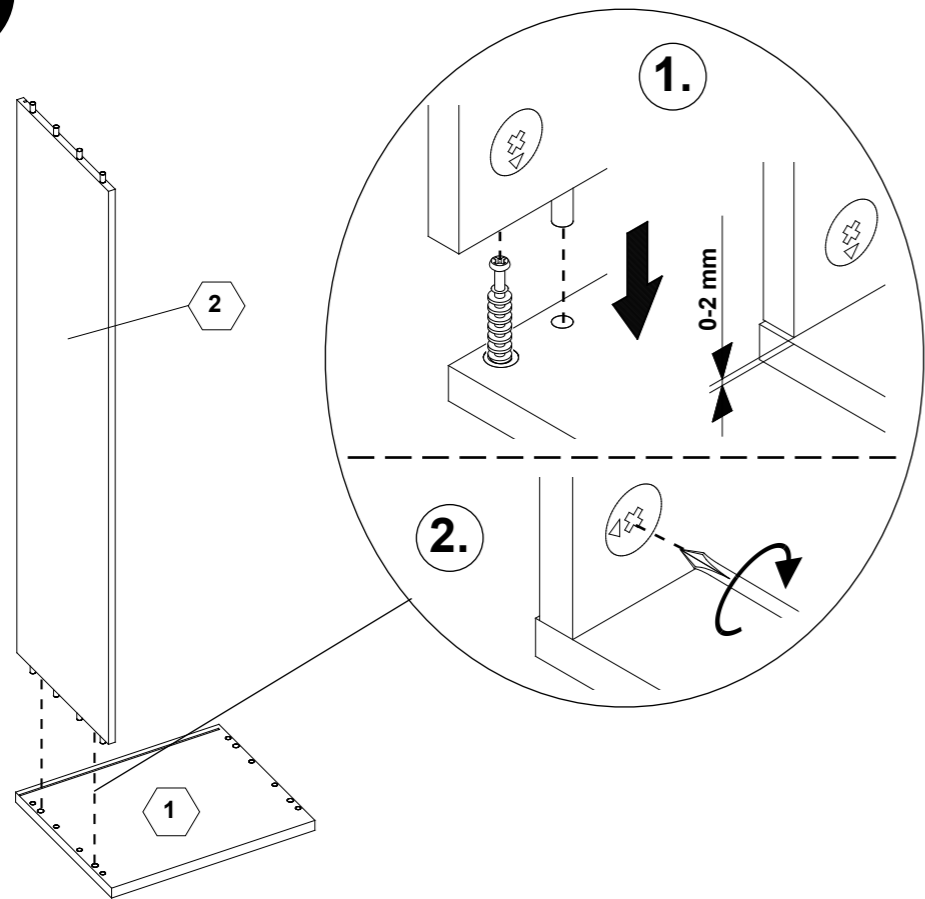

**2**

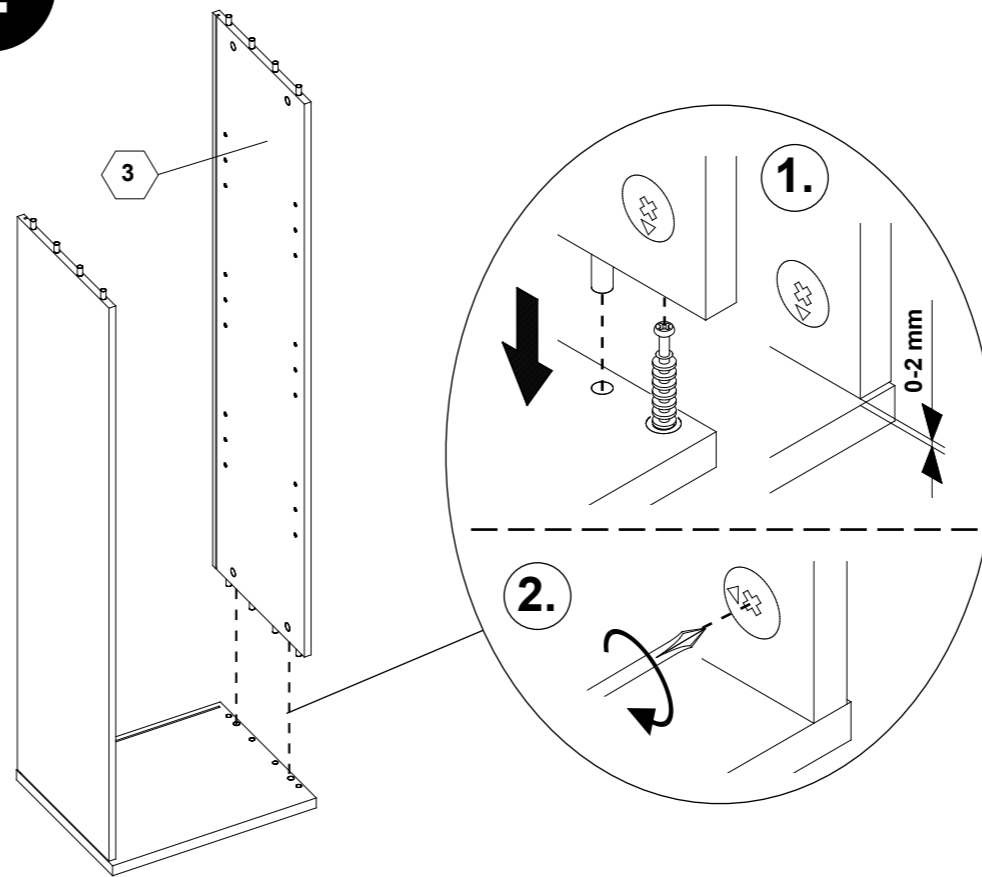

**3**

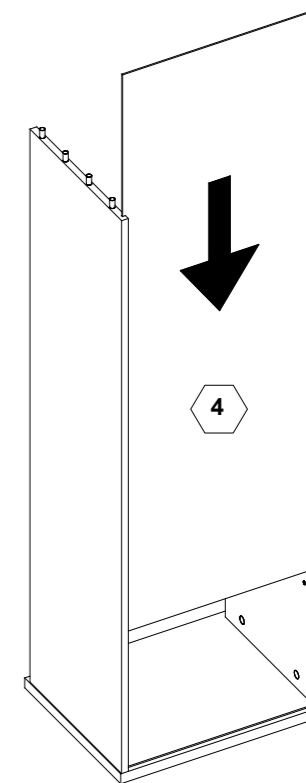

**4**

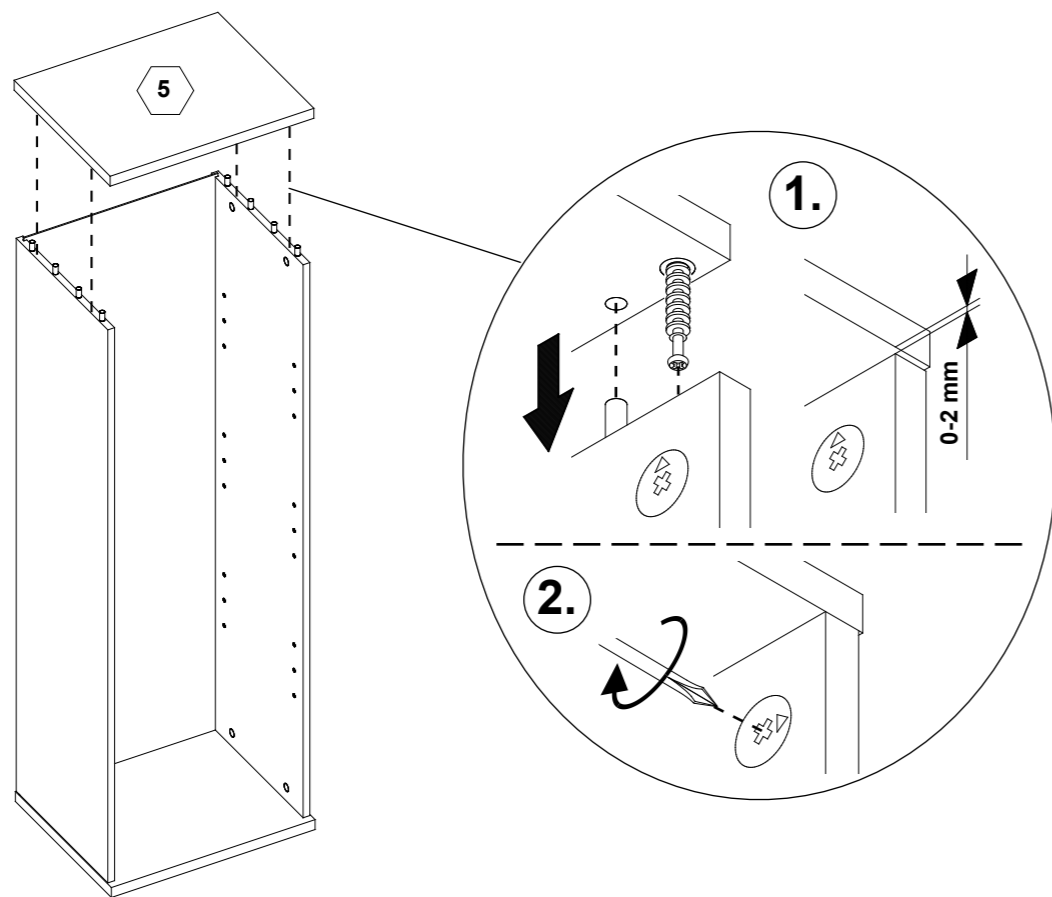

**5**

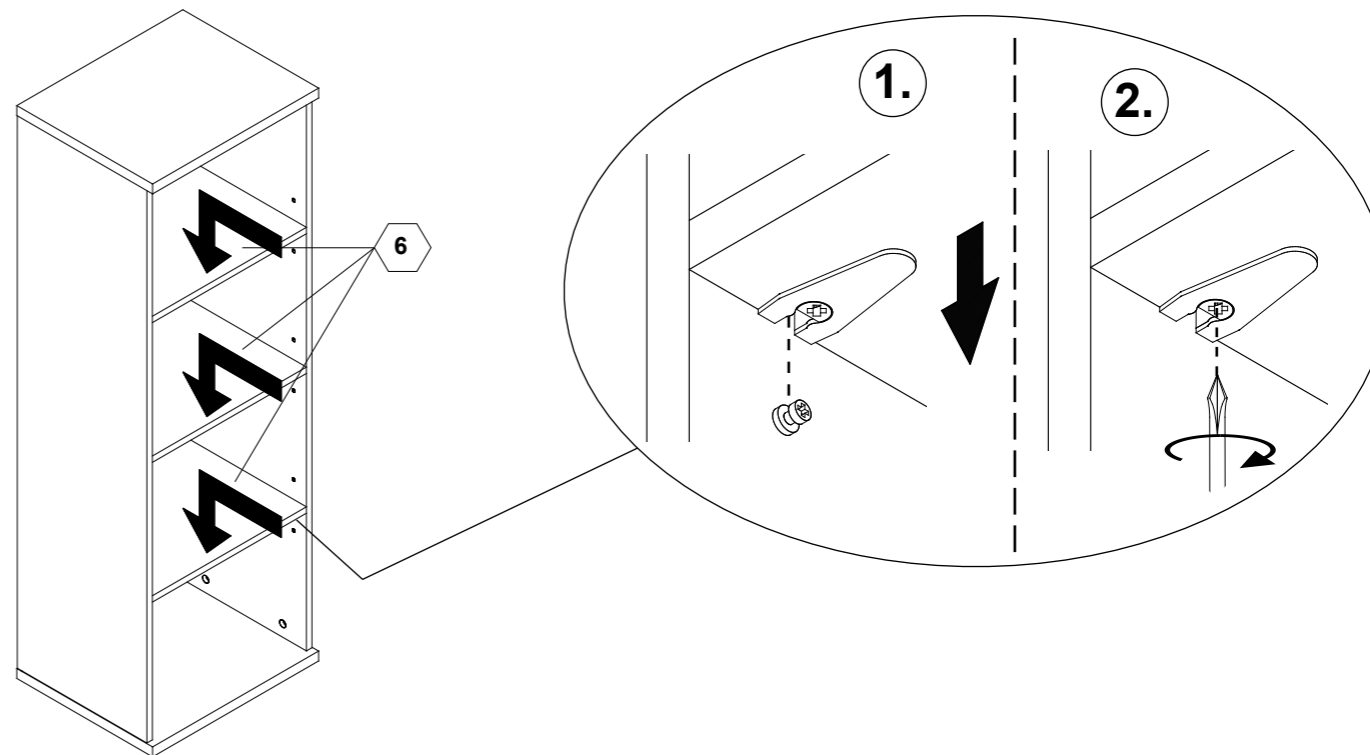

6

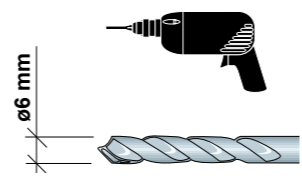
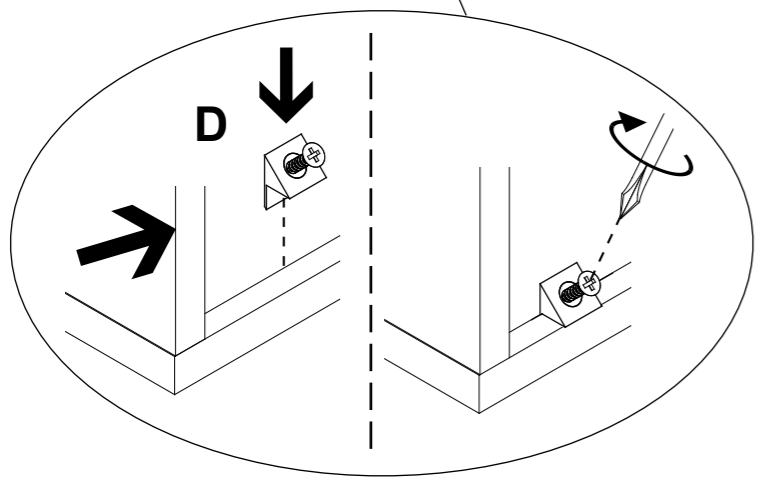
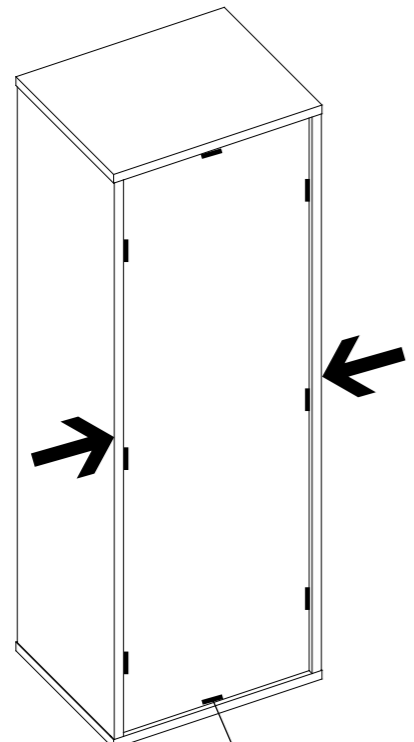

# Wandbefestigung

**ACHTUNG !!**  
Beiliegende Wandbefestigungsmaterial ist nur für massives Mauerwerk geeignet. Bei massiv abweichendem Mauerwerk müssen geeignete Befestigungsmaterialien verwendet werden. Prüfen Sie ob die notwendige Festigkeit gewährleistet ist.

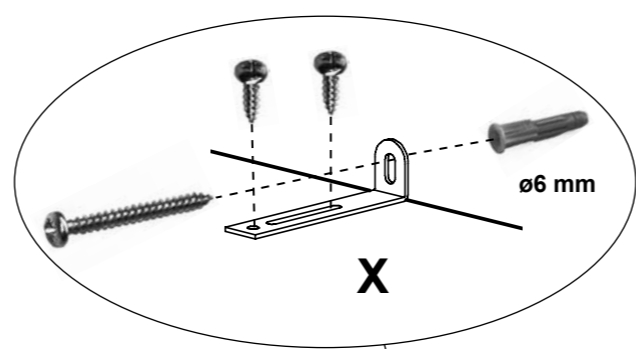

138 6226

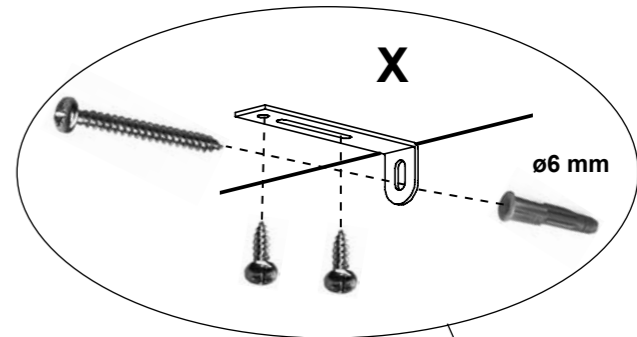
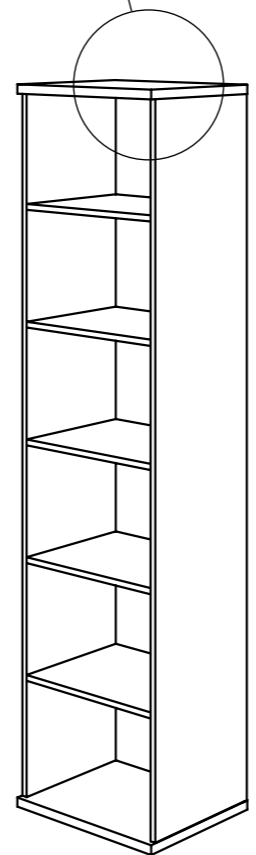

138 6126

